

# GOODSON

---

*Tools and Supplies for Engine Builders*

---

## 2016

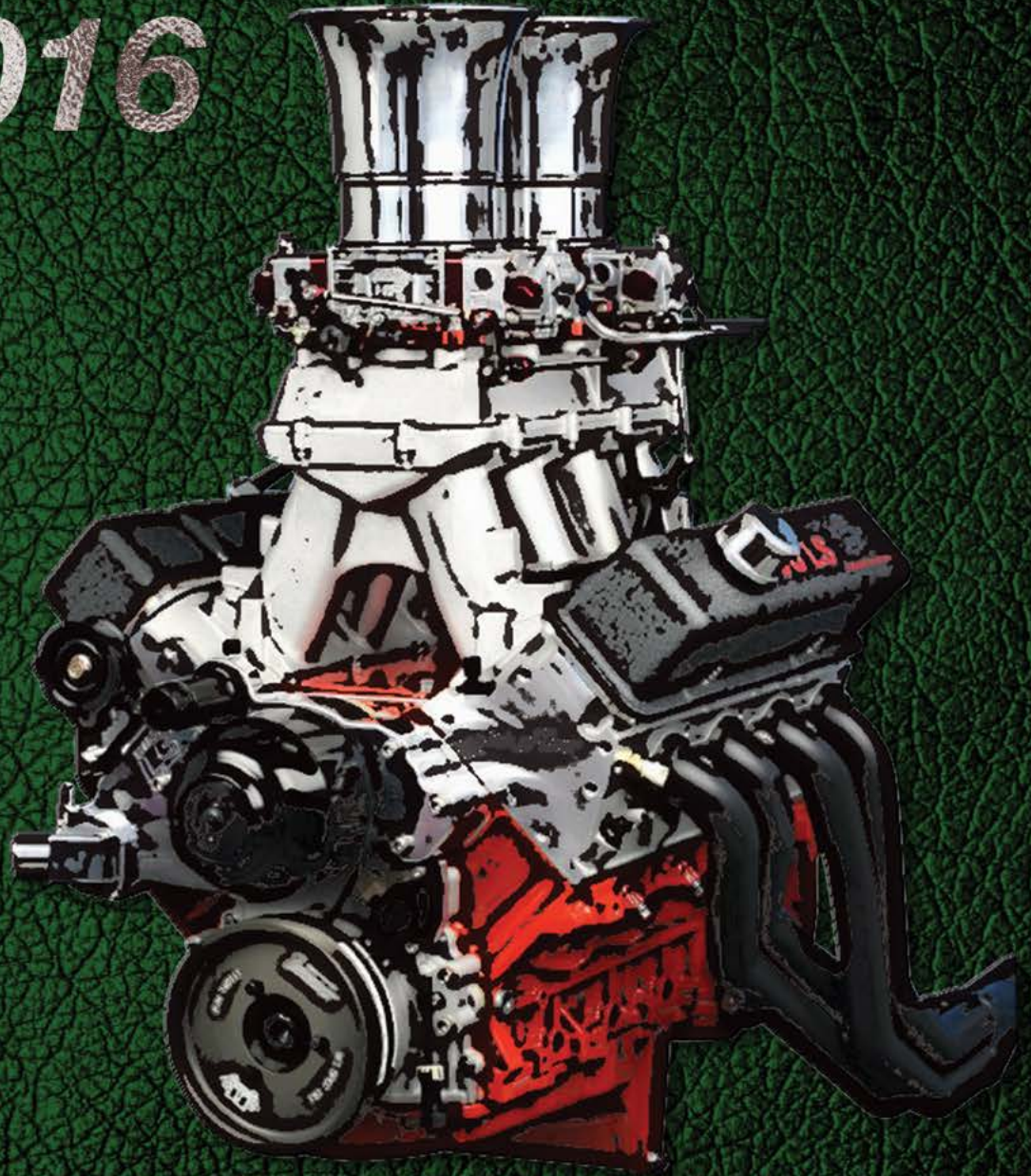

---

Toll-Free 800-533-8010 • Phone 507-452-1830 • [www.goodson.com](http://www.goodson.com)

---

# From the President's Desk

What is a classic? Defined, it means "judged over a period of time to be of the highest quality. The word conjures images of classic cars (who could forget the '57 Chevy?), classic movies (remember American Graffiti) or classical music (think Beethoven's 5th Symphony). In the Automotive Aftermarket, **Goodson Tools & Supplies** stands as a classic.

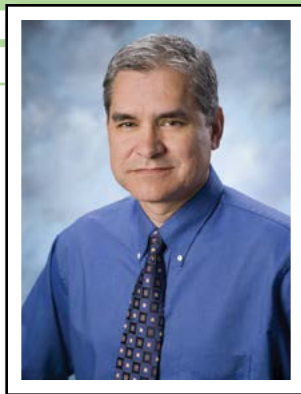

Juan Roque,  
Goodson President

## CLASSIC:

- a : serving as a standard of excellence : of recognized value
- b : of enduring interesting, quality or style

As we enter our 71st year of being in the Automotive Aftermarket, we promise to provide quality products at competitive prices, backed by the best customer service in the industry. But don't take our word for it, experience first hand the classic customer service only Goodson can provide; call, fax, email or order online. We will do everything we can to continue earning your business by providing **FULL SERVICE FAST!**

## GOODSON Ironclad Guarantee

Goodson won't risk losing your business for any reason. If you're not 100% satisfied with your purchase, we'll fix it, exchange it or credit your account for the purchase price. To send an item back, just include a note detailing the reason for the return and ship it back, freight pre-paid within 60 days. The only time we can't honor this guarantee is if a tool has been damaged through misuse or modification. All abrasives have a shelf life so we can only guarantee them for one year from the original purchase date.



Erik Shepard

## Goodson Techxperts™ on staff to help you

When you have questions about product applications, tooling interchangeability,



Chris Jensen

machining procedures, extending tool life, engine specs or any other technical topic, give the Goodson Tech Services Department a call at 1-800-533-8010.

## Contact Us

Customer service representatives are available from 7:30am - 5:30pm, Mon. - Fri. and our Techxperts™ are on hand from 8am - 5pm, Mon. - Fri. (Central time)

Phone: 1-800-533-8010 (US & Canada)  
1-507-452-1830 (International)

Fax: 1-888-466-3909 (US & Canada)  
1-507-452-2907 (International)

Please note that the Goodson offices will be closed in observance of the following 2016 holidays: New Years Day (January 1), Memorial Day (May 30), Independence Day (July 4), Labor Day (September 5), Thanksgiving (November 24 & 25), Christmas (December 26) and New Year's Eve (December 31).



## THANK YOU Mike Mavrigian!

Once again, our friend, Mike Mavrigian of [Birchwood Automotive Group](#) has come through with a beautiful photo of an engine for use on our catalog cover.

Mike Mavrigian is a well known engine builder and technical writer whose articles and photography have appeared in industry publications such as Engine Builder, Engine Professional, Auto Service Professional and The Shop.

**We're always open on the web!**

**Web: [www.goodson.com](http://www.goodson.com)**

**Email: [orderdesk@goodson.com](mailto:orderdesk@goodson.com)**

## Policies

See the last page of the Index for more information about these policies.

## Pricing:

Prices are subject to change without notice. There is no minimum order. Orders are billed at the prices in effect at the time of shipping. Discounts are not available on Sunnen® products.

## Shipping:

Goodson typically ships orders the same day they are received. Orders received after hours, on weekends or holidays are shipped the next business day. If your order is lost in shipping, Goodson works with the shipper to provide tracking service. Please inspect all shipments upon receipt and report damage or errors within 48 hours.

## Freight:

For orders shipped ground within the USA, you may deduct the freight charges on any **JOBBER** net invoice of \$800 or more if you pay within 30 days of the invoice date. Glass Beads, Steel Shot, Tumbler Media, Machines, Equipment, Bulk Liquids and Crankwheels are not included. Hazardous Materials, Dangerous Goods & Dimensional Shipping fees may apply on some items.

## Terms:

- 1) A 1% discount is given on merchandise if payment is made within 15 days from **invoice** date. This discount applies to the merchandise amount only (not the total amount) on the **invoice** (not a statement). The discount amount is shown in the lower left hand corner of the invoice. This discount does not apply to statement payments and does not apply to credit card orders.
- 2) Invoices not paid in full within 30 days from the statement date are subject to a finance charge of 1.5% per month (18% per year).

## Credit & Debit Card Orders:

Goodson accepts MasterCard, Visa, American Express and Discover Card. For your security, credit card numbers are **NOT** kept on file. Credit card orders do not qualify for the 1% quick-pay discount.

## Check Acceptance:

In the unlikely event that your check is returned for insufficient or held funds, we will debit your checking account electronically for the face amount of the check plus the service fee allowed by your state's law. This allows us to resolve the problem without turning you over to a collection agency and harming your credit rating. The transaction will appear on your bank statement and no one will have to contact you about payment.

## Returns:

You may return any item, except special orders, within 60 days. We will do our best to correct any problems or to send a replacement. If an item was damaged through mis-use or modification, Goodson will not accept it as a return. Credits will only be issued after it is determined that the part is resellable or it is deemed defective.

**ABRASIVES WARRANTY:** Abrasives have a shelf life, therefore, all abrasives are warranted against manufacturing defects for 1 year from the date of original purchase.

**RESETTING/RESHARPENING SERVICE:** Premium Diamonds can be reset and many of our cutting tools can be resharpened. Send your resets and resharpers to GOODSON Tools & Supplies, ATTN: Resharpers, 156 Galewski Dr. Winona, MN 55987. Be sure to include your customer number.

A rapid-use index of product categories

## Cylinder Head Rebuilding

Pilots.....	1-3
Valve Seat Work.....	4-21
Valve Refacing.....	22-23
Reamers.....	24-25
Valve Guide Resizing.....	26-28
Valve Guide Replacement.....	29-34
Valve Seal Work.....	35
Valve Spring Work.....	36-42
Cylinder Head Resurfacing.....	43-46
Crack Detection & Repair.....	47-51
Porting & Polishing.....	57-60

## Cleaning, Assembly & Safety

Parts Storage & Organizers.....	61, 69
Wire Wheels & Brushes.....	62-63
Cleaning.....	63-68
Parts Baskets.....	68
Last Blast Paint & Metal Markers.....	70
Flex-Hones®.....	72

## Index Falls between pages 72 & 73

Coolants & Lubricants.....	73
----------------------------	----

## Short Block Rebuilding

Cylinder Boring & Honing.....	74-80
Boring Bar Tooling & Supplies.....	74-75
Honing Stones.....	76-80
Rod Honing.....	82-83
Rod & Piston Work.....	84-89
Lifter Bore Tooling.....	91
Camshaft Work.....	92-93

## Crankshaft/Flywheel Grinding

Crankshaft Grinding Wheels.....	94-95
Crankshaft Grinding & Polishing.....	96-100
Flywheel Grinding.....	101-103

## Miscellaneous Tools

Diamond Dresser Tools.....	104-105
Machine Replacement Parts.....	107-109
Technical Manuals & Videos.....	109

## Brake & Tire Changing Tools

Brake Tips & Holders.....	110-111
Brake Lathe Silencers.....	112
Brake Lathe Replacement Parts.....	113-115
Brake Lathe Mounting Adaptors.....	116-116

## Measuring Tools

Micrometers.....	118
Calipers & Dial Indicators.....	119
Dial Bore Gauges.....	120-121

## V-Twin & Metric Hard Parts

Seats & Seat Inserts.....	123
Valve Guides.....	124, 128
Replacement Valves.....	125
Valve Springs.....	126-127

© Copyright 2016, Goodson Mfg. Co., Inc. All copy and illustrations are copyrighted. Absolutely no mechanical or electronic reproduction or use of any part is allowed without our prior written permission. Goodson reserves the right to correct printing errors. Prices are subject to change without notice.

## WAA High-Performance Vitrified Crankshaft Wheels

These high-performance wheels offer excellent dimensional accuracy, corner radii and surface finish. A single grade covers multiple applications including weld grinding.

- Ideal for grinding anything from cast to steel
- Finishing and roughing wheel • Aluminum Oxide
- Light to medium stock removal • Blue/white in color (Due to manufacturing process, colors may vary) • Wheel speeds to 8500 SFPM

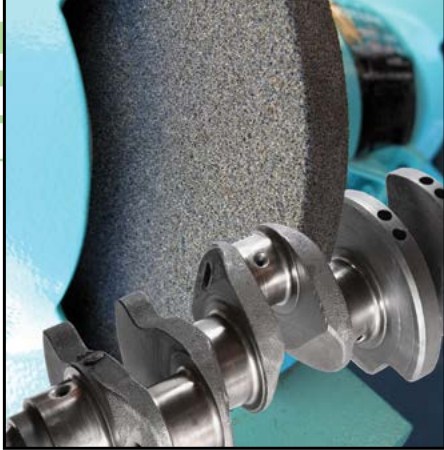

### WAA (54 Grit)

Dia.	Width	Jobber
<b>Fits Storm Vulcan 14, 15</b>		
18" Arbor	3/4" - 1"	\$189.99
3" Arbor	1 1/64" - 1 1/4"	189.99
	1 17/64" - 1 1/2"	219.99
	1 33/64" - 1 3/4"	239.99
1 49/64" - 2"	269.99	
<b>Fits Storm Vulcan 15, 15 Special, 1550, 1648</b>		
20"	3/4" - 1"	\$209.99
3" Arbor	1 1/64" - 1 1/4"	219.99
	1 17/64" - 1 1/2"	269.99
	1 33/64" - 1 3/4"	279.99
	1 49/64" - 2"	299.99
<b>Fits Kwik-Way / Lempco</b>		
20"	3/4" - 1"	\$209.99
3 3/4" Arbor	1 1/64" - 1 1/4"	219.99
	1 17/64" - 1 1/2"	254.99
	1 33/64" - 1 3/4"	289.99
	1 49/64" - 2"	319.99
<b>Fits Kwik-Way / Lempco TKG Series, 519</b>		
22"	3/4" - 1"	\$209.99
3 3/4" Arbor	1 1/64" - 1 1/4"	219.99
	1 17/64" - 1 1/2"	249.99
	1 33/64" - 1 3/4"	279.99
	1 49/64" - 2"	299.99
<b>Fits Storm Vulcan 15A (to serial #593) &amp; AMC</b>		
22"	3/4" - 1"	\$279.99
5" Arbor	1 1/64" - 1 1/4"	289.99
	1 17/64" - 1 1/2"	299.99
	1 33/64" - 1 3/4"	339.99
	1 49/64" - 2"	369.99
<b>Fits Peterson Berco 180</b>		
22"	3/4" - 1"	\$294.99
8" Arbor	1 1/64" - 1 1/4"	314.99
	1 17/64" - 1 1/2"	319.99
	1 33/64" - 1 3/4"	399.99
	1 49/64" - 2"	369.99
<b>Fits Storm Vulcan 15A, 5A Special, 5C, 1860; RMC/Robbi Rex 1200 and Scledum 200</b>		
24"	3/4" - 1"	\$299.99
5" Arbor	1 1/64" - 1 1/4"	309.99
	1 17/64" - 1 1/2"	349.99
	1 33/64" - 1 3/4"	379.99
	1 49/64" - 2"	399.99

More crankshaft grinding wheels are shown on page 95

### WAA (54 Grit)

Dia.	Width	Jobber
<b>Fits Lempco KGA &amp; NKG; and Kwik-Way</b>		
24"	3/4" - 1"	\$299.99
5" Arbor	1 1/64" - 1 1/4"	309.99
	1 17/64" - 1 1/2"	339.99
	1 33/64" - 1 3/4"	369.99
	1 49/64" - 2"	399.99
<b>Fits WVN 438, 448, 460 &amp; 465</b>		
24"	3/4" - 1"	\$319.99
8" Arbor	1 1/64" - 1 1/4"	329.99
	1 17/64" - 1 1/2"	349.99
	1 33/64" - 1 3/4"	369.99
	1 49/64" - 2"	389.99
<b>Fits Storm Vulcan 5C (serial #173 &amp; up)</b>		
25"	3/4" - 1"	\$369.99
5" Arbor	1 1/64" - 1 1/4"	399.99
	1 17/64" - 1 1/2"	429.99
	1 33/64" - 1 3/4"	459.99
	1 49/64" - 2"	489.99
<b>Fits AMC K-1100, K-1400, K-1500, K-1800; Peterson Berco 180B, 225A, 225B, 225C &amp; RT225; Winona Van Norman 438, 448, 460, 465, 475, 476 &amp; CG210, Zanrosso 210 &amp; 230, RG 230; New Scledum; Storm Vulcan 230 Std.; Storm Vulcan 230 Prod.; Scledum 200, 230</b>		
26"	3/4" - 1"	\$429.99
8" Arbor	1 1/64" - 1 1/4"	449.99
	1 17/64" - 1 1/2"	469.99
	1 33/64" - 1 3/4"	489.99
	1 49/64" - 2"	529.99
<b>Fits Kwik-Way KGB-C-E; Lempco KG1049, KG1050, KG1051, KG1122, KG1123, KG1170 and KG B-C-E</b>		
28"	3/4" - 1"	\$379.99
6" Arbor	1 1/64" - 1 1/4"	409.99
	1 17/64" - 1 1/2"	439.99
	1 33/64" - 1 3/4"	469.99
	1 49/64" - 2"	499.99
<b>Fits Peterson Berco 260, 260A, 260B, 270A, 270B, 270C; Winona Van Norman 400, 438, 439, 475, 476, 477, 666 &amp; CG-250; Scledum RG 270, RG270Y, RG280; Zanrosso Series; Robbie Rex 1500</b>		
28"	3/4" - 1"	\$479.99
8" Arbor	1 1/64" - 1 1/4"	519.99
	1 17/64" - 1 1/2"	549.99
	1 33/64" - 1 3/4"	569.99
	1 49/64" - 2"	599.99
2 1/64" - 2 1/4"	629.99	

### WAA (54 Grit)

Dia.	Width	Jobber
<b>Fits Winona Van Norman; Zanrosso 280; AMC 2000; Storm Vulcan/Scledum 270, 280; RMC/Robbi Rex 1800, 2200L, 2700RM, 300RM</b>		
30"	3/4" - 1"	\$554.99
8" Arbor	1 1/64" - 1 1/4"	554.99
	1 17/64" - 1 1/2"	674.99
	1 33/64" - 1 3/4"	674.99
1 49/64" - 2"	819.99	
<b>Fits Winona Van Norman 467, 471, 477, 472, CG 280, CG 300; Zanrosso 280; AMC Machine 1400, K1500, K1800</b>		
32"	3/4" - 1"	\$624.99
8" Arbor	1 1/64" - 1 1/4"	624.99
	1 17/64" - 1 1/2"	624.99
	1 33/64" - 1 3/4"	624.99
	1 49/64" - 2"	894.99
<b>Fits Peterson Berco TM 280, 300 &amp; 300A; Scledum 280</b>		
32"	3/4" - 1"	\$664.99
12" Arbor	1 1/64" - 1 1/4"	769.99
	1 17/64" - 1 1/2"	829.99
	1 33/64" - 1 3/4"	829.99
	1 49/64" - 2"	829.99
<b>Fits Peterson Berco 300, 350, 350A, 350B, 350C &amp; 350D; Scledum; Winona Van Norman 111</b>		
36"	3/4" - 1"	\$ 874.99
12" Arbor	1 1/64" - 1 1/4"	874.99
	1 17/64" - 1 1/2"	974.99
	1 33/64" - 1 3/4"	1029.99
	1 49/64" - 2"	1174.99
2 1/64" - 2 1/4"	1174.99	



### Cam & Crank Grinding Coolant

- Semi synthetic • Non-nitrite
- High-lubricity • Dilute 20:1

Size	Jobber	Order No.
1 gallon /3.78L	\$ 33.99	CGC-10
5 gallons /18.93L	149.99	CGC-50

Ask about Special Order

## 60 GRIT Premium Abrasive (43A)

Contact Goodson at 1-800-533-8010 for information.

## Camshaft Grinding Wheels

Most cam grinding machines are custom fitted to the part being ground. When generating cam shapes, some variation in grain and grade can improve the results. **WAA54-L5-V1** is a multi-purpose vitrified wheel that is free-cutting & offers great durability. **43A602-K8-V1** is a premium multi-purpose wheel, offering great durability and free cutting. **7BL801** is designed for steel rollers and 8620 chilled cast **WAA100** is a 100 grit premium multi-purpose abrasive for cast iron and steel.

WAA54-L5-V1				
Dia.	Width	Arbor	Jobber	Order No.
18"	3/4"	6"	\$194.99	E341420
	7/8"	6"	194.99	E335351
	1"	6"	194.99	E335352
	1 1/8"	6"	214.99	E335353
	1 1/4"	6"	214.99	E335354
43A602-K8-V1				
Dia.	Width	Arbor	Jobber	Order No.
18"	3/4"	6"	\$179.99	E342030
	7/8"	6"	189.99	E339945
	1"	6"	194.99	E342031
	1 1/4"	6"	217.99	E348558

7BL801				
Dia.	Width	Arbor	Jobber	Order No.
18"	3/4"	6"	\$249.99	E416880
	7/8"	6"	249.99	E427392
WAA100				
Dia.	Width	Arbor	Jobber	Order No.
18"	3/4"	6"	\$194.99	E379225
	7/8"	6"	209.99	E397667
	1"	6"	209.99	E416878
	1 1/4"	6"	209.99	E416183

**All Radiac Camshaft Grinding Wheels are the same grit, grain and bond that you have ordered in the past!**

## Diamond Impregnated Cam Dresser

- 7/16" x 1 1/4" OAL • 15°
- Order No. [2V9507](#)
- Jobber \$99.99



## Precision Made Valve Refacer Wheels

Radiac manufactures many popular sizes and shapes of Valve Refacer Wheels using top quality grain for every wheel. Every Valve Refacer Wheel is thoroughly tested for size, shape and balance.

Choose from these types: **GP** = General Purpose, **ST** = Stainless, **T** = Titanium, **F** = Finishing

Colors may vary due to manufacturing process.

Machine	Use	Dimensions	Shape	Type	Models	Color	Jobber	Order No.	
Black & Decker	Valve	4" x 1" x 5/8"	Offset	GP	A to EF	Red/White	\$54.99	F167851	
	Stem	4" x 1" x 5/8"	Cup	GP	Most	Gray	42.99	F336037	
		4" x 1 1/8" x 1 1/2"	Cup	GP	All	Gray	37.99	7336038	
Comec	Valve	215 x 35 x 76mm	Flared	GP	VR-416, RV-516	Gray	104.99	G400086	
IDL / Sunnen®	Valve	8" x 1 1/4" x 1 1/2"	Flared	GP	CG50, CG80, CG82, VR-7000, VR-8000, V90	Orange	59.99	G393775	
			Flared	ST	CG50, CG80, CG82, VR-7000, VR-8000, V90	White	107.99	G344815	
Winona			Flared	GP	CG50, CG80, CG82, VR-7000, VR-8000, V90	Ruby	62.99	G387105	
KO Lee	Valve	5" x 3/4" x 5/8"	Offset/15°	GP	K103A, 303, 403 & 500	Red/White	46.99	F336035	
	Stem	4" x 1" x 5/8"	Cup	GP	K500C, K403C	Gray	42.99	F336037	
Kwik-Way	Valve	5" x 7/8" x 7/8"	Offset	ST	VS	Red/White	89.99	F257738	
			Offset	ST, T	VS	Green	114.99	F389354	
		7" x 1 9/16" x 7/8"	Offset	GP	SVS & SVSII	Orange	64.36	F372239	
			Offset	F	SVS & SVSII	Brown	54.99	F426141	
			Offset	F	SVS & SVSII	White	69.99	F342482	
			Offset	GP	SVS & SVSII	Ruby	67.99	F377419	
	Stem	8" x 1 3/8" x 7/8"	Offset	GP	VL	Gray	119.99	G358784	
			Cup	GP	All Models except VL	Gray	37.99	F336036	
Rottler	Valve	7" x 1" x 7/8"	Offset	GP	VR-7	Orange	64.36	F372239	
			Offset	F	VR-7	White	69.99	F342482	
			Offset	F	VR-7	Brown	54.99	F426141	
			Offset	GP	VR-7	Ruby	67.99	F377419	
Stem	3" x 1 1/4" x 5/8"	Cup	GP	VR-7	Gray	37.99	F336036		
Sioux™	Valve	4" x 1" x 5/8"	Offset	GP	All Models	Red/White	54.99	F167851	
			7" x .675" x 1 3/4"	Straight/15°	GP	2001, 2075, 680 & 956	Orange	42.99	A364068
				Straight/15°	F	2001, 2075, 680 & 956	White	42.99	A324814
				Straight/15°	F	2001, 2075, 680 & 956	Brown	42.99	A424892
				Straight/15°	GP	2001, 2075, 680 & 956	Ruby	42.99	A379613
Straight/15°	ST, T	2001, 2075, 680 & 956	Green	64.99	A340229				
Snap-On	Valve	5" x 3/4" x 5/8"	Offset/15°	GP	All Models	Red/White	46.99	F336035	
	Stem	4" x 1 1/8" x 1 1/2"	Cup	GP	All Models	Gray	37.99	7336038	
Sunnen® (TA)	Valve	6" x 1 3/8" x 3/4"	Flared	ST	VR-6500	Gray	119.99	F345291	
	Stem	5" x 1 3/8" x 3/4"	Cup	GP	VR-6500	Gray	49.99	F345599	

Colors may vary due to manufacturing process

CYLINDER HEAD REBUILDING  
CLEANING, ASSEMBLY & SAFETY  
SHORT BLOCK REBUILDING  
CRANKSHAFT/FLYWHEEL GRINDING  
MISCELLANEOUS TOOLS & SUPPLIES  
BRAKE & TIRE CHANGING TOOLS  
MEASURING TOOLS  
V-TWIN & METRIC HARD PARTS



"In addition to the wide selection of tools and supplies found in this catalog, we have access to hundreds of hard-to-find tools not shown due to their specialized nature. If you're looking for a special tool, call us and we'll help you find it."

- Wendy, Purchasing, 29 years of service

CYLINDER HEAD REBUILDING  
CLEANING, ASSEMBLY & SAFETY  
SHORT BLOCK REBUILDING  
CRANKSHAFT/ FLYWHEEL GRINDING  
MISCELLANEOUS TOOLS & SUPPLIES  
BRAKE & TIRE CHANGING TOOLS  
MEASURING TOOLS  
V-TWIN & METRIC HARD PARTS



### Rod & Cap Grinding Wheels

- For Sunnen® and other popular brandcap grinders
- 6" x 2" x 1 1/4"
- Fits CRG 700, 750, 770, 780, 805 & 920K
- Order No. F343793 Jobber \$69.99



### Ring Squaring Tools

- Minimizes ring overworking
- Helps keep the ring square while measuring ring gap
- Positive support
- Works well with narrow or light tension rings
- 4 sizes available
- Each size fits multiple bore sizes
- Easy to use

Bore Range	Jobber	Order No.
3.000" to 3.350"	\$99.99	<u>RST-3000-3350</u>
3.300" to 3.650"	99.99	<u>RST-3300-3650</u>
3.900" to 4.250"	99.99	<u>RST-3900-4250</u>
4.200" to 4.550"	99.99	<u>RST-4200-4550</u>

Other sizes available as special order. Contact Goodson for ordering information



### Premium Aluminum Oxide Super Flexible Crankshaft Polishing Belts

- Resin bonded J-Weight backing material
- Super flexible materials allows the user to push the belt up on the crankshaft radius for smoother finish
- 1" wide belts • 10 per package

Grit	Jobber	64"	Jobber	72"
240	\$22.99	<u>C355337</u>	\$24.99	<u>C355358</u>
320	22.99	<u>C355341</u>	24.99	<u>C355360</u>
400	22.99	<u>C355347</u>	24.99	<u>C355362</u>

Other Sizes Available by Special Order

### 6100g Digital Balancing Scale

- 0.1g readability
- 7 units of measure including grams, ounces, pounds, troy ounces, mommes, pennyweights, grains and pieces
- Stainless Steel weighing pan measures 127 x 140mm / 5"x5.5"
- Easy-to-read LCD display with backlight
- Runs on 4AA batteries or with AC Adaptor (included)
- Adjustable feet for easy leveling
- Order No. BS-6100 Jobber \$579.99



American Made

### Steel Double Harley Head Plate

This Double Head Plate is designed to accommodate two heads at the same time. Its unique design gives perfect alignment of the centerline of valve guides, providing repeatable accuracy from head to head. The plate is heavy enough for cutting and installing guides and seats. It is designed to be used on a seat and guide machine or Bridgeport-type Mill, including CNC machines. Measures 10" x 22" x 1" thick and includes 3/8" dowel pins. Blackened steel construction.  
Order No. HHP-23 Jobber \$749.99



### Extra Long Manual Valve Guide Drivers

- Corrosion resistant finish
- Rockwell hardness of 45 to 50
- Pilots are slightly smaller than the guide ID for easy removal
- 1° negative angle to prevent guide mushrooming
- 8" OAL • Pilot approximately 1" long
- NOTE:** Due to the nature of these valve guide drivers, they cannot be warranted against breakage, but are guaranteed for dimensional accuracy.

Guide OD	Driver OD	Pilot	Jobber	Order No.
mm	in.	mm	in.	
4.0	.157"	9.0	.355"	3.80 .150" \$20.99 <u>GPL-2240-G</u>
4.5	.177"	9.0	.355"	4.30 .170" 20.99 <u>GPL-2245-G</u>
5.0	.196"	9.0	.355"	4.75 .187" 20.99 <u>GPL-2250-G</u>
5.5	.217"	10.5	.412"	5.21 .205" 20.99 <u>GPL-2255-G</u>
6.0	.230"	9.1	.358"	5.72 .225" 20.99 <u>GPL-2258-G</u>
6.0	.236"	10.5	.412"	5.72 .225" 20.99 <u>GPL-2260-G</u>

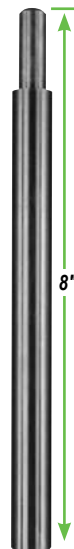

### Core Drill Reamer & Cast Iron Valve Guides for 7.3 Powerstroke

- Specifically sized to work together

Description	Size	Jobber	Order No.
Cobalt Core Drill Reamer	.311" x .5628"	\$197.99	<u>CDR-563-CB</u>
Cast Iron Valve Guides	.3146"IDx.5652"ODx2.44"OAL	3.29	<u>CIG-8476</u>

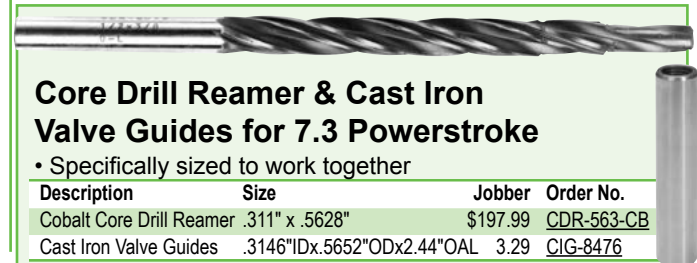



Order 3 or more Flywheel Grinding Stones (any combination) and take 10% off Jobber

### SILICON-CARBIDE ABRASIVE Ductile Iron, Cast Iron & Steel (Black)

Dimensions	Hardness	Shape	Jobber	Order No.
3" / 2 1/2" x 1 1/2" x 1/4"	Med. Hard	Flared	\$34.99	U364512
4" / 3" x 2" x 1/4"	Med. Soft	Flared	67.99	U335369
6" / 4 1/2" x 2 1/2" x 1/4"	Soft	Flared	52.99	U324494
	Med. Soft	Flared	44.99	U324495
	Med. Hard	Flared	47.99	U335376
	Hard	Flared	47.99	U335377
	Med. Soft	Flared	47.99	U357854
Med. Hard	Flared	57.99	U343805	

### EXTENDED LIFE CERAMIC Ductile Iron, Cast Iron and Steel (Black)

Dimensions	Hardness	Shape	Jobber	Order No.
6" / 4 1/2" x 3" x 1/4"	Med. Hard	Flared	\$103.99	U370095

### ALUMINUM-OXIDE ABRASIVE Mild Steel & Hardened Steel (White)

Dimensions	Hardness	Shape	Jobber	Order No.
6" / 4 1/2" x 2 1/2" x 1/4"	Soft	Flared	\$99.99	F342636
	Medium	Flared	52.99	F335373

### ALUMINUM-OXIDE ABRASIVE

Light to Medium Stock Removal on Steel, Cast Iron & Ductile Iron (Ruby)

Dimensions	Hardness	Shape	Jobber	Order No.
4" / 3" x 2" x 1/4"	Medium	Flared	\$57.99	F348769
6" / 4 1/2" x 2 1/2" x 1/4"	Soft	Flared	62.99	F372039
	Med. Soft	Flared	62.99	F348771
	Medium	Flared	64.99	F348772
	Hard	Flared	62.99	F348773

Colors may vary due to the manufacturing process

**tech tips**  
from the techxperts™  
**Never dress your Superabrasive with the dresser attachment on your machine**



## FlyMaster® CBN Super Abrasive Flywheel Grinding Wheels

• For cast iron • Light to heavy applications

Dimensions	Abrasive	Shape	Jobber	Order No.
2" / 1 1/2" x 1/8" x 3/8"	CBN	Cup	\$119.99	2H0998
3" x 1 1/4" x 1 1/4"	CBN	Straight	189.99	261453
3 3/4" / 2 5/8" x 1 1/2" x 1 1/4"	CBN	Cup	199.99	2371052
5" / 3 3/4" x 1 3/4" x 1 1/4"	CBN	Cup	209.99	2379270
6" / 4 5/8" x 1 7/8" x 1 1/4"	CBN	Cup	219.99	2367275*
CBN Dressing Stick 1/2" x 1/2" x 6"			16.99	DS-CBN

\*Most popular application

## tech tips

from the techxperts™

Hardness	Qualities
Soft	Aggressive
Med. Soft	Little or No Dressing
Med. Hard	Good Cutting
Hard	Some Dressing, Long Life

See page 102 for Wheel Dressers and Replacement Parts



## Flywheel Spindle Adaptor for 2" Superabrasive Cup

This special adaptor is needed for Audi and some Volkswagen applications. Complete unit includes Adaptor Spindle, Flange and Bolt. Order No. 7401842 Jobber \$109.99

## tech tips

from the techxperts™

### Instructions for Using FlyMaster® Superabrasive CBN Wheels

1. Set the motor spindle 90° to the cutting turntable. Look for cross-hatch patterns in the flywheel.
2. Machine must be clean and have fresh water with fresh coolant (FG-1101-G) mixed at 8 - 10%.
3. **Never dress your Superabrasive with the dresser attachment on your machine.** Dress with a hand-held dresser stick (DS-CBN).
4. Flood the wheel with coolant (FG-1101-G) to keep cutting edge clean and cool.
5. Use very light pressure while cutting.

CYLINDER HEAD REBUILDING  
CLEANING, ASSEMBLY & SAFETY  
SHORT BLOCK REBUILDING  
CRANKSHAFT/ FLYWHEEL GRINDING  
MISCELLANEOUS TOOLS & SUPPLIES  
BRAKE & TIRE CHANGING TOOLS  
MEASURING TOOLS  
V-TWIN & METRIC HARD PARTS

CYLINDER HEAD  
CLEANING, ASSEMBLY & SAFETY  
SHORT BLOCK REBUILDING  
CRANKSHAFT/ FLYWHEEL GRINDING  
MISCELLANEOUS TOOLS & SUPPLIES  
BRAKE & TIRE CHANGING TOOLS  
MEASURING TOOLS  
V-TWIN & METRIC HARD PARTS



## Single Piece Resurfacer Wheels

- Wheels meet or exceed standards established for general purpose grinding applications • Banding wears off to expose more abrasive

Dimensions	Application	Grit	Jobber	Order No.
12" x 3" x 9"	Kwik-Way, Lempco 545, 545H, 855	36	\$379.99	<b>U350423</b>
14" x 1½" x 6"	All Peterson 14" Dry Grinders	36	329.99	<b>U338279</b>
		24	329.99	<b>U342040</b>
16" x 3" x 13" (1½" Rim)	Kwik-Way 545-BL, 860A, L & T	24	479.99	<b>U342550</b>
	Kwik-Way 860A, L & T (softer, better finish)	36	479.99	<b>U422304</b>

## Surface Grinding Segments

- **Black** Silicon-Carbide for Cast Iron and Aluminum
- **Ruby** Aluminum-Oxide for Cast Iron and Steel
- **Salt & Pepper (S&P)** Silicon-Carbide / Aluminum-Oxide mix for Cast Iron & Steel



Order a Set of 8 or more Surface Grinding Segments and take 10% off Jobber

### STORM VULCAN

Machine	Dia.	Segments	Segment Size	Color	Jobber	Order No.
RT-17Y S/N Up to 128696	12½"	8	79x21x79mm	Ruby	29.84	<b>P348642</b>
				S&P	19.99	<b>P348643</b>
RT-17Y S/N Up to 103151	14"	10	79x21x79mm	Ruby	29.84	<b>P348642</b>
				S&P	19.99	<b>P348643</b>
RT-17Y Late Serial No. 128697 & Up	14"	10	65x25x100mm	Black	18.99	<b>P337252</b>
				Ruby	18.99	<b>P337253</b>
				S&P	18.99	<b>P337254</b>
RT-7Y Late Serial No. 103152 & Up	16"	10	65x25x100mm	Black	18.99	<b>P337252</b>
				Ruby	18.99	<b>P337253</b>
				S&P	18.99	<b>P337254</b>

### PETERSON BERCO

Machine	Dia.	Segments	Segment Size	Color	Jobber	Order No.
RSC 50				Black	\$18.99	<b>P337252</b>
RSC 950	12"	8	65x25x100mm	Ruby	18.99	<b>P337253</b>
				S&P	18.99	<b>P337254</b>
RSC1200				Black	18.99	<b>P337252</b>
RSC1550	14"	10	65x25x100mm	Ruby	18.99	<b>P337253</b>
STC361/1300				S&P	18.99	<b>P337254</b>
RSC1200				Black	18.99	<b>P337252</b>
RSC1500	16"	12	65x25x100mm	Ruby	18.99	<b>P337253</b>
RPY S1500				S&P	18.99	<b>P337254</b>
1055				Black	18.99	<b>P337252</b>
1055 AWL	18"	14	65x25x100mm	Ruby	18.99	<b>P337253</b>
STC461/2000				S&P	18.99	<b>P337254</b>
RG32	12"	8	79x21x79mm	Ruby	29.84	<b>P348642</b>
				S&P	19.99	<b>P348643</b>

### WINONA VAN NORMAN, ZANROSSO

Machine	Dia.	Segments	Segment Size	Color	Jobber	Order No.
SM2000	13"	8		Black	\$18.99	<b>P337252</b>
4000, 5000	13½"	10	65x25x100mm	Ruby	18.99	<b>P337253</b>
6000	17½"	12		S&P	18.99	<b>P337254</b>

### DCM

Machine	Dia.	Segments	Segment Size	Color	Jobber	Order No.
280M, 3800	12"	10		Black	\$18.99	<b>P337252</b>
5400	12"	10	65x25x100mm	Ruby	18.99	<b>P337253</b>
5400	14"	14		S&P	18.99	<b>P337254</b>

Due to manufacturing processes, actual colors may vary

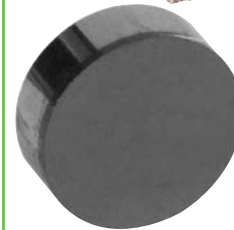

## PCD Inserts for Aluminum

- A must for shops committed to meeting today's strict surface finish requirements
- Fits machines with ½" type CBN holder
- Use with Resurfacing Spray (HPS-16) for best results

Size	Jobber	Order No.
½" x ¾" Single Sided	\$227.99	<b>2379265</b>
High Performance Resurfacing Spray	11.99	<b>HPS-16*</b>

\*Hazardous Goods Fees Apply When Shipped by Air

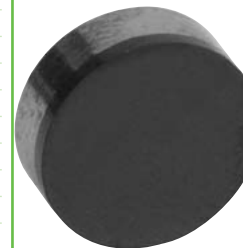

## Uncoated CBN Cutter Inserts For Cast Iron

- Faster and cleaner than segments and wheels

Dia.	Thick.	Sided	Jobber	Order No.
¾"	1/8"	Single (DCM, Rottler)	\$184.99	<b>2X5346</b>
	3/16"	Solid	239.99	<b>2359232</b>
½"	1/8"	Single	324.99	<b>2X5357</b>
	1/8"	Solid	199.99	<b>2X5299</b>
	3/16"	Single	209.99	<b>2359233</b>
	3/16"	Special Edge Prep		
		Diesel	199.99	<b>2379268</b>
	1/16"	Thick Carbide Shim	21.99	<b>CBN-500SHIM</b>



**Hex Drive Seat Grinding Kit**  
includes everything listed below.  
Everything comes packed in  
a handy storage case.

### Valve Seat Grinding Sets

Order the set as-is or modify a set to meet your specific needs. Set contents include:

Description	OE Number	Jobber	Order No.	Includes
<b>45° Hex Drive Motor Seat Grinding Set (110V, 50/60 Hz)</b>		\$3699.99	<a href="#">SGH-110-KIT</a>	▼
<b>45° Hex Drive Motor Seat Grinding Set (220V, 50/60Hz)</b>		3799.99	<a href="#">SGH-220-KIT</a>	▼
<b>Flex Drive Motor Seat Grinding Set (110V, 50/60 Hz)</b>		3899.99	<a href="#">SGF-110-KIT</a>	▼
<b>Flex Drive Motor Seat Grinding Set (220V, 50/60Hz)</b>		3999.99	<a href="#">SGF-220-KIT</a>	▼
Hex Drive Seat Grinder - 45° 110V, 50/60Hz	031-3100-20	1299.99	<a href="#">031-3100-20</a>	1
Hex Drive Seat Grinder - 45° 220V, 50/60Hz	031-3100-27	1399.99	<a href="#">031-3100-27</a>	1
Flex Drive Seat Grinder 110V, 50/60Hz	031-3000-15	1399.99	<a href="#">031-3000-15</a>	1
Flex Drive Seat Grinder 220V, 50/60Hz	031-3000-35	1499.99	<a href="#">031-3000-35</a>	1
Universal Wheel Dresser w/G-13P Diamond	n/a	599.99	<a href="#">SWD-UNI</a>	1 1 1 1
Replacement Dressing Stand Diamond	n/a	79.99	<a href="#">G-13P</a>	
Dressing Stand Pilot with .437" Top	031-0202-80	149.99	<a href="#">031-0202-80</a>	1 1
Dressing Stand Pilot with .437" Top	031-1102-89	149.99	<a href="#">031-1102-89</a>	1 1
Stone Holder - 13/16" x 13 Thread w/Plunger	031-0300-30	379.99	<a href="#">031-0300-30</a>	2 2
Flex-Drive Stone Holder with Stabilizer	031-0300-64	399.99	<a href="#">031-0300-64</a>	2 2
Heavy Duty Plastic Storage Box	001-1000-25	49.99	<a href="#">SG-CASE</a>	1 1 1 1
Seat Stone Removal Tool	n/a	24.99	<a href="#">KW-SRT</a>	1 1 1 1
Leather Washer / Vibration Reducer (3 Pc.)	031-1009-41	11.99	<a href="#">KHW-3</a>	1 1 1 1
<b>.437" Top Pilots</b>	<b>Dia./mm</b>			
	.2755" / 7.00mm	030-0237-30	\$57.99 <a href="#">P-5275K</a>	1 1 1 1
	.2760" / 7.01mm	n/a	57.99 <a href="#">P-5276K</a>	1 1 1 1
	.2763" / 7.02mm	030-0237-40	57.99 <a href="#">P-5277K</a>	1 1 1 1
	.3125" / 7.93mm	030-0239-35	57.99 <a href="#">P-5312K</a>	1 1 1 1
	.3135" / 7.96mm	030-0239-51	57.99 <a href="#">P-5313K</a>	1 1 1 1
	.3145" / 7.98mm	030-0239-78	57.99 <a href="#">P-5314K</a>	1 1 1 1
	.3149" / 8.00mm	030-0239-94	57.99 <a href="#">P-5315K</a>	1 1 1 1
	.3437" / 8.72mm	030-0242-73	57.99 <a href="#">P-5343K</a>	1 1 1 1
	.3447" / 8.75mm	030-0243-03	57.99 <a href="#">P-5344K</a>	1 1 1 1
	.3457" / 8.78mm	030-0243-11	57.99 <a href="#">P-5345K</a>	1 1 1 1
	.3730" / 9.47mm	030-0247-70	57.99 <a href="#">P-5373K</a>	1 1 1 1
	.3750" / 9.52mm	030-0247-70	57.99 <a href="#">P-5375K</a>	1 1 1 1
<b>General Purpose Valve Seat Grinding Stones (1/8" x 13)</b>		<b>30°</b>		<b>45°</b>
1.375" / 35mm	\$13.99 <a href="#">KW-1130-GP</a>	1 1 1 1	\$13.99 <a href="#">KW-1145-GP</a>	1 1 1 1
1.500" / 38mm	13.99 <a href="#">KW-1230-GP</a>	1 1 1 1	13.99 <a href="#">KW-1245-GP</a>	1 1 1 1
1.615" / 41mm	13.99 <a href="#">KW-1330-GP</a>	1 1 1 1	13.99 <a href="#">KW-1345-GP</a>	1 1 1 1
1.750" / 44mm	13.99 <a href="#">KW-1430-GP</a>	1 1 1 1	13.99 <a href="#">KW-1445-GP</a>	1 1 1 1
1.785" / 47mm	13.99 <a href="#">KW-1530-GP</a>	1 1 1 1	13.99 <a href="#">KW-1545-GP</a>	1 1 1 1
2.000" / 51mm	13.99 <a href="#">KW-1630-GP</a>	1 1 1 1	13.99 <a href="#">KW-1645-GP</a>	1 1 1 1
2.125" / 54mm	13.99 <a href="#">KW-1730-GP</a>	1 1 1 1	13.99 <a href="#">KW-1745-GP</a>	1 1 1 1
<b>Finishing Valve Seat Grinding Stones (1/8" x 13)</b>		<b>30°</b>		<b>45°</b>
1.375" / 35mm	\$13.99 <a href="#">KW-1130-F</a>	1 1 1 1	\$13.99 <a href="#">KW-1145-F</a>	1 1 1 1
1.500" / 38mm	13.99 <a href="#">KW-1230-F</a>	1 1 1 1	13.99 <a href="#">KW-1245-F</a>	1 1 1 1
1.625" / 41mm	13.99 <a href="#">KW-1330-F</a>	1 1 1 1	13.99 <a href="#">KW-1345-F</a>	1 1 1 1
1.750" / 44mm	13.99 <a href="#">KW-1430-F</a>	1 1 1 1	13.99 <a href="#">KW-1445-F</a>	1 1 1 1
1.785" / 47mm	13.99 <a href="#">KW-1530-F</a>	1 1 1 1	13.99 <a href="#">KW-1545-F</a>	1 1 1 1
2.000" / 51mm	13.99 <a href="#">KW-1630-F</a>	1 1 1 1	13.99 <a href="#">KW-1645-F</a>	1 1 1 1
2.125" / 54mm	13.99 <a href="#">KW-1730-F</a>	1 1 1 1	13.99 <a href="#">KW-1745-F</a>	1 1 1 1

**KWIK-WAY**  
Seat Grinding Equipment & Supplies  
**GOODSON**  
Tools and Supplies for Engine Builders

**American Made**



### 45° Kwik-Way Hex Drive (SGH) Electric Motor Unit

- Heavy duty electric motor
- 11,500 RPM
- Weighs 9 lbs.
- 3/5 HP, 7.5 Amps

Description	Jobber	Order No.
110V, 50/60Hz	\$1299.99	<a href="#">031-3100-20</a>
220V, 50/60Hz	1399.99	<a href="#">031-3100-27</a>



### Flex Drive (SGF) Heavy Duty Electric Motor Unit

- Heavy duty electric motor
- Flex Drive allows for slight operator misalignment
- 11,500 RPM
- 3/5 HP, 7.5 Amps
- Must use with Flex Stone Holder (031-0300-64)

Description	Jobber	Order No.
110V, 50/60Hz	\$1399.99	<a href="#">031-3000-15</a>
220V, 50/60Hz	1499.99	<a href="#">031-3000-35</a>



### Optional Heavy Duty Dressing Stand

- Order No. [031-1900-02](#)

Jobber \$1129.99

See page 20 for details

CYLINDER HEAD REBUILDING ASSEMBLY & SAFETY CLEANING, SHORT BLOCK REBUILDING FLYWHEEL GRINDING TOOLS & SUPPLIES CRANKSHAFT/ MISCELLANEOUS BRAKE & TIRE MEASURING TOOLS V-TWIN & METRIC HARD PARTS

**KWIK-WAY**  
 Seat Grinding Equipment & Supplies  
MFG BY

# GOODSON

Tools and Supplies for Engine Builders



## 45° Sioux-Style (SGK) Spline Drive Electric Motor Unit

- Heavy duty electric motor
- 11,500 RPM
- Weighs 9 lbs.
- 3/5 HP • 7.5 Amps

Description	Jobber	Order No.
110V, 50/60Hz	\$1329.99	031-3100-21
220V, 50/60Hz	1499.99	031-3100-28



034-3112-00      031-3112-17

## Replacement Drive Assemblies

- Easy to install
- Always keep one on hand for emergencies

Description	Jobber	Order No.
Spline Drive	\$74.99	034-3112-00
Hex Drive w/Leather Washer	74.99	031-3112-17
Replacement Leather Washer	3.99	031-1009-41

## Sioux-Style Valve Seat Grinding Kits

These kits include everything you need to get started in seat grinding. Choose between kits including 110V and 220V Spline Drive Electric Grinders. After that, everything else in the kit is identical. We started with the most common sizes of pilots and valve seat stones, but you can customize one of these kits to meet your specific needs. Call 1-800-533-8010 for additional information.

Description	OE Number	Jobber	Order No.	Includes
45° Spline Drive Motor Seat Grinding Set (110V, 50/60 Hz)		\$3099.99	SGK-110-KIT	▼
45° Spline Drive Motor Seat Grinding Set (220V, 50/60Hz)		3199.99	SGK-220-KIT	▼
Seat Grinding Kit Without Driver	n/a	1599.99	SGK-385	▼
Spline Drive Seat Grinder - 45° 110V, 50/60 Hz	031-3100-21	1329.99	031-3100-21	1
Spline Drive Seat Grinder - 45° 220V, 50/60 Hz	031-3100-28	1499.99	031-3100-28	1
Universal Seat Wheel Dresser w/G-13P Diamond	n/a	599.99	SWD-UNI	1 1 1
Replacement Dressing Diamond	n/a	79.99	G-13P	
Dressing Stand Pilot	031-0202-55	149.99	031-0202-55	1 1 1
Stone Holder - 3/8" x 16 Thread	1702	125.99	SX-HOLDER	2 2 2
Heavy Duty Plastic Storage Box	001-1000-25	49.99	SG-CASE	1 1 1
Seat Stone Removal Tool	n/a	24.99	SX-SRT	1 1 1
Bounce Spring Set (3 Pc.)	n/a	16.99	BSS-100	1 1 1
Leather Washer / Vibration Reducer (3 Pc.)	031-1009-41	11.99	SHW-3	1 1 1
<b>.385" Top Pilots    Dia./mm</b>				
.2755" / 7.00mm		\$47.99	P-5275S	1 1 1
.2763" / 7.02mm		47.99	P-5277S	1 1 1
.2775" / 7.05mm		47.99	P-5278S	1 1 1
.3125" / 7.93mm		47.99	P-5312S	1 1 1
.3135" / 7.96mm		47.99	P-5313S	1 1 1
.3145" / 7.98mm		47.99	P-5314S	1 1 1
.3149" / 8.00mm		47.99	P-5315S	1 1 1
.3437" / 8.72mm		47.99	P-5343S	1 1 1
.3447" / 8.75mm		47.99	P-5344S	1 1 1
.3457" / 8.78mm		47.99	P-5345S	1 1 1
.3750" / 9.52mm		47.99	P-5375S	1 1 1
.3780" / 9.60mm		47.99	P-5378S	1 1 1
<b>General Purpose Seat Grinding Stones (1/16"x16)</b>				
		<b>30°</b>		<b>45°</b>
1.375" / 35mm	\$13.49	SX-1130-GP	1 1 1	\$13.49 SX-1145-GP 1 1 1
1.500" / 38mm	13.49	SX-1230-GP	1 1 1	13.49 SX-1245-GP 1 1 1
1.625" / 41mm	13.49	SX-1330-GP	1 1 1	13.49 SX-1345-GP 1 1 1
1.750" / 44mm	13.49	SX-1430-GP	1 1 1	13.49 SX-1445-GP 1 1 1
1.785" / 47mm	13.49	SX-1530-GP	1 1 1	13.49 SX-1545-GP 1 1 1
2.000" / 51mm	13.49	SX-1630-GP	1 1 1	13.49 SX-1645-GP 1 1 1
2.125" / 54mm	13.49	SX-1730-GP	1 1 1	13.49 SX-1745-GP 1 1 1
<b>Finishing Valve Seat Grinding Stones (1/16"x16)</b>				
		<b>30°</b>		<b>45°</b>
1.375" / 35mm	\$13.49	SX-1130-F	1 1 1	\$12.99 SX-1145-F 1 1 1
1.500" / 38mm	11.49	SX-1230-F	1 1 1	11.49 SX-1245-F 1 1 1
1.625" / 41mm	11.49	SX-1330-F	1 1 1	11.49 SX-1345-F 1 1 1
1.750" / 44mm	11.49	SX-1430-F	1 1 1	11.49 SX-1445-F 1 1 1
1.785" / 47mm	11.49	SX-1530-F	1 1 1	11.49 SX-1545-F 1 1 1
2.000" / 51mm	11.49	SX-1630-F	1 1 1	11.49 SX-1645-F 1 1 1
2.125" / 54mm	11.99	SX-1730-F	1 1 1	11.99 SX-1745-F 1 1 1

CYLINDER HEAD REBUILDING  
 CLEANING, ASSEMBLY & SAFETY  
 SHORT BLOCK REBUILDING  
 CRANKSHAFT/ FLYWHEEL GRINDING  
 MISCELLANEOUS TOOLS & SUPPLIES  
 BRAKE & TIRE CHANGING TOOLS  
 MEASURING TOOLS  
 V-TWIN & METRIC HARD PARTS

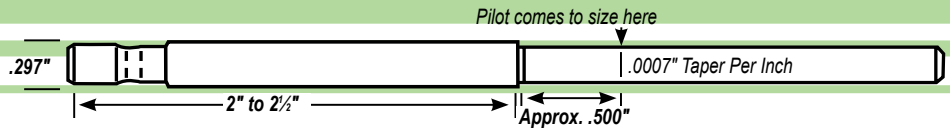

### .297" Solid-Tapered High Speed Steel Pilots

Inch	mm	OAL	Order No.
.1496	3.80	3.375"	P-1149N
.1574	4.00	4.50"	P-1158N
.1582	4.02	4.50"	P-1159N
.1771	4.50	4.50"	P-1177N

Jobber \$23.99

Inch	mm	OAL	Order No.
.1779	4.52	4.50"	P-1178N
.1968	5.00	4.50"	P-1197N
.1976	5.02	4.50"	P-1198N
.2165	5.50	4.50"	P-1216N

Jobber \$23.99

Inch	mm	OAL	Order No.
.2173	5.52	4.50"	P-1217N
.2362	6.00	4.50"	P-1236N
.2370	6.02	4.50"	P-1237N
.2381	6.05	4.50"	P-1238N

Jobber \$23.99

Inch	mm	OAL	Order No.
.2490	6.32	4.50"	P-1249N
.2500	6.35	4.50"	P-1250N
.2510	6.37	4.50"	P-1251N
.2598	6.60	4.50"	P-1260N
.2755	7.00	4.50"	P-1275N

Jobber \$23.99

Inch	mm	OAL	Order No.
.3120	7.92	4.50"	P-1312N
.3130	7.95	4.50"	P-1313N
.3149	8.00	4.50"	P-1315N
.3427	8.72	4.50"	P-1343N

Jobber \$23.99

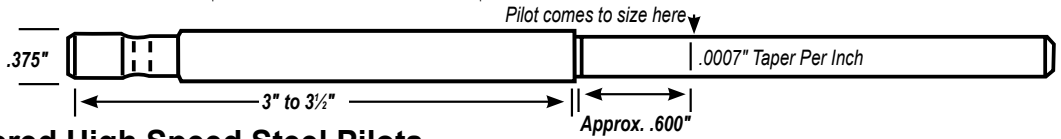

### .375" Solid-Tapered High Speed Steel Pilots

Inch	mm	OAL	Order No.
.1771	4.50	6.00"	P-5177N
.1960	4.98	6.00"	P-5196N
.1968	5.00	6.00"	P-5197N
.1976	5.02	6.00"	P-5198N
.2165	5.50	6.00"	P-5216N
.2173	5.52	6.00"	P-5217N
.2185	5.55	6.00"	P-5218N
.2354	5.98	6.00"	P-5235N
.2362	6.00	6.00"	P-5236N
.2370	6.00	6.00"	P-5237N
.2381	6.05	6.00"	P-5238N
.2393	6.08	6.00"	P-5239N

Jobber \$35.99

Inch	mm	OAL	Order No.
.2490	6.32	6.00"	P-5249N
.2500	6.35	6.00"	P-5250N
.2510	6.37	6.00"	P-5251N
.2559	6.50	6.00"	P-5256N
.2566	6.52	6.00"	P-5257N
.2590	6.58	6.00"	P-5258N
.2598	6.60	6.00"	P-5260N
.2748	6.98	6.00"	P-5274N
.2756	7.00	6.00"	P-5275N
.2763	7.02	6.00"	P-5277N
.2775	7.05	6.00"	P-5278N
.2792	7.09	6.00"	P-5279N

Jobber \$35.99

Inch	mm	OAL	Order No.
.2952	7.50	6.00"	P-5295N
.2960	7.52	6.00"	P-5296N
.3095	7.86	6.00"	P-5309N
.3105	7.88	6.00"	P-5310N
.3115	7.91	6.00"	P-5311N
.3125	7.93	6.00"	P-5312N
.3135	7.96	6.00"	P-5313N
.3145	7.98	6.00"	P-5314N
.3149	8.00	6.00"	P-5315N
.3165	8.03	6.00"	P-5316N
.3397	8.62	6.50"	P-5339N
.3407	8.65	6.50"	P-5340N

Jobber \$35.99

Inch	mm	OAL	Order No.
.3417	8.67	6.50"	P-5341N
.3427	8.70	6.50"	P-5342N
.3437	8.72	6.50"	P-5343N
.3447	8.75	6.50"	P-5344N
.3457	8.78	6.50"	P-5345N
.3543	9.00	6.50"	P-5354N
.3551	9.02	6.50"	P-5355N
.3587	9.11	6.50"	P-5358N
.3730	9.47	7.00"	P-5373N
.3740	9.49	7.00"	P-5374N
.3750	9.52	7.00"	P-5375N
.3760	9.55	7.00"	P-5376N
.3770	9.57	7.00"	P-5377N

Jobber \$35.99

Inch	mm	OAL	Order No.
.3780	9.60	7.00"	P-5378N
.3790	9.62	7.00"	P-5379N
.3820	9.70	7.00"	P-5382N
.3937	10.00	7.00"	P-5394N
.4331	11.00	7.75"	P-5433N
.4365	11.08	7.75"	P-5436N
.4375	11.11	7.75"	P-5437N
.4385	11.13	7.75"	P-5438N
.4395	11.16	7.75"	P-5439N

Jobber \$35.99

.5000" 12.70 7.75" P-5500N

.5010" 12.72 7.75" P-5501N

.5020" 12.75 7.75" P-5502N

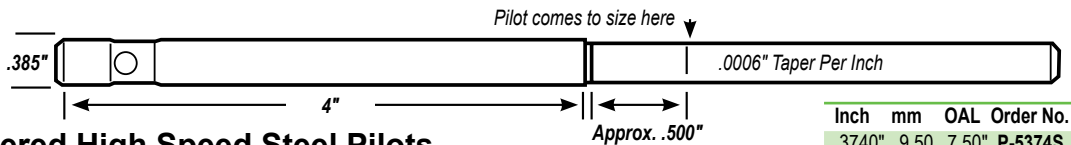

### .385" Solid-Tapered High Speed Steel Pilots

Inch	mm	OAL	Order No.
.1560	3.96	6.25"	P-5156S
.1570	3.97	6.125"	P-5157S
.1580	4.01	6.125"	P-5158S
.1770	4.50	6.125"	P-5177S
.1960	4.98	6.125"	P-5196S
.1968	5.00	6.125"	P-5197S
.1980	5.03	6.25"	P-5198S
.2165	5.50	7.50"	P-5216S
.2173	5.52	7.50"	P-5217S
.2180	5.54	6.25"	P-5218S
.2350	5.97	7.50"	P-5235S
.2362	6.00	7.50"	P-5236S

Jobber \$47.99

Inch	mm	OAL	Order No.
.2370	6.02	7.50"	P-5237S
.2381	6.05	7.50"	P-5238S
.2393	6.08	7.50"	P-5239S
.2500	6.35	7.50"	P-5250S
.2510	6.38	7.50"	P-5251S
.2580	6.55	6.25"	P-5258S
.2596	6.57	7.50"	P-5259S
.2598	6.60	7.50"	P-5260S
.2610	6.62	7.50"	P-5261S
.2620	6.65	7.50"	P-5262S
.2744	6.97	7.50"	P-5274S
.2755	7.00	7.50"	P-5275S

Jobber \$47.99

Inch	mm	OAL	Order No.
.2763	7.02	7.50"	P-5276S
.2771	7.04	7.50"	P-5277S
.2779	7.06	7.50"	P-5278S
.2791	7.09	7.50"	P-5279S
.3100	7.87	7.50"	P-5310S
.3110	7.89	7.50"	P-5311S
.3125	7.94	7.50"	P-5312S
.3130	7.95	7.50"	P-5313S
.3141	7.98	7.50"	P-5314S
.3149	8.00	7.50"	P-5315S
.3161	8.03	7.50"	P-5316S
.3170	8.05	7.50"	P-5317S

Jobber \$47.99

Inch	mm	OAL	Order No.
.3181	8.08	7.50"	P-5318S
.3400	8.63	7.50"	P-5340S
.3410	8.66	7.50"	P-5341S
.3420	8.68	7.50"	P-5342S
.3430	8.71	7.50"	P-5343S
.3440	8.73	7.50"	P-5344S
.3450	8.76	7.50"	P-5345S
.3543	9.00	7.50"	P-5354S
.3550	9.02	7.50"	P-5355S
.3560	9.04	7.50"	P-5356S
.3580	9.09	7.50"	P-5358S
.3730	9.47	7.50"	P-5373S

Jobber \$47.99

Inch	mm	OAL	Order No.
.3740	9.50	7.50"	P-5374S
.3750	9.53	7.50"	P-5375S
.3760	9.55	7.50"	P-5376S
.3770	9.58	8.00"	P-5377S
.3780	9.60	8.00"	P-5378S
.3790	9.63	8.00"	P-5379S
.3820	9.70	8.00"	P-5382S
.3930	9.98	8.00"	P-5393S
.3937	10.00	8.00"	P-5394S
.4330	11.00	8.00"	P-5433S

Jobber \$47.99

.5000" 12.70 8.75" P-5500S

.5010" 12.73 8.75" P-5501S

.5020" 12.75 8.75" P-5502S

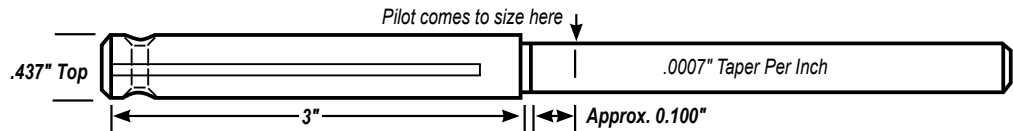

### .437" Solid-Tapered High Speed Steel Pilots

Inch	mm	OAL	Order No.
.1770	4.50	6.25"	P-5177K
.1960	4.98	6.25"	P-5196K
.1970	5.00	6.25"	P-5197K
.1976	5.02	6.25"	P-5198K
.2160	5.50	6.75"	P-5216K
.2170	5.52	6.75"	P-5217K
.2185	5.55	6.75"	P-5218K
.2354	5.98	6.75"	P-5235K
.2362	6.00	6.75"	P-5236K

Jobber \$57.99

Inch	mm	OAL	Order No.
.2370	6.02	6.75"	P-5237K
.2381	6.05	6.75"	P-5238K
.2490	6.32	6.25"	P-5249K
.2500	6.35	6.25"	P-5250K
.2510	6.38	6.25"	P-5251K
.2580	6.55	6.25"	P-5258K
.2590	6.58	6.25"	P-5259K
.2600	6.60	6.25"	P-5260K
.2610	6.63	6.25"	P-5261K

Jobber \$57.99

Inch	mm	OAL	Order No.
.2755	7.00	6.75"	P-5275K
.2760	7.01	6.75"	P-5276K
.2763	7.02	6.75"	P-5277K
.2787	7.08	6.75"	P-5279K
.3100	7.88	6.75"	P-5310K
.3115	7.90	6.75"	P-5311K
.3125	7.94	6.75"	P-5312K
.3135	7.96	6.75"	P-5313K
.3145	7.98	6.75"	P-5314K

Jobber \$57.99

Inch	mm	OAL	Order No.
.3150	8.00	6.75"	P-5315K
.3157	8.02	6.75"	P-5316K
.3169	8.05	6.75"	P-5317K
.3180	8.08	6.75"	P-5318K
.3417	8.68	6.75"	P-5341K
.3427	8.70	6.75"	P-5342K
.3437	8.73	6.75"	P-5343K
.3440	8.74	8.00"	P-5344K
.3457	8.78	6.75"	P-5345K

Jobber \$57.99

Inch	mm	OAL	Order No.
.3543	9.00	6.75"	P-5354K
.3550	9.03	6.75"	P-5355K
.3587	9.09	6.75"	P-5358K
.3730	9.47	6.75"	P-5373K
.3740	9.50	6.75"	P-5374K
.3750	9.52	6.75"	P-5375K
.3790	9.63	6.75"	P-5379K
.3937	10.00	6.75"	P-5394K

Jobber \$57.99



## .375" Top Expanding Pilots

• Expand up to .020" (.51mm) • Includes Collet & Expander

Size	mm	Range	Pilot	Collet	Expander
.216"	5.50	.213"-.233"	P-5.5MMNX	P-216-COLLET	P-1216-EXP
.236"	6.00	.233"-.253"	P-6MMNX	P-6MM-COLLET	P-1236-EXP
.250"	6.35	.247"-.267"	P-250NX	P-250-COLLET	P-1250-EXP
.256"	6.50	.253"-.273"	P-6.5MMNX	P-65MM-COLLET	P-6.5MM-EXP
.275"	7.00	.272"-.292"	P-7MMNX	P-7MM-COLLET	P-7MM-EXP
.312"	7.92	.309"-.329"	P-312NX	P-312-COLLET	P-343-EXP
.335"	8.50	.330"-.350"	P-8.5MMNX	P-343-COLLET	P-343-EXP
.343"	8.70	.340"-.360"	P-343NX	P-343-COLLET	P-343-EXP
.354"	9.00	.350"-.370"	P-9MMNX	P-375-COLLET	P-375-EXP
.375"	9.50	.372"-.392"	P-375NX	P-375-COLLET	P-375-EXP
.393"	10.00	.390"-.410"	P-10MMNX	P-10MM-COLLET	P-10MM-EXP
.437"	11.00	.430"-.450"	P-11MMNX	P-11MM-COLLET	P-11MM-EXP
.453"	11.50	.450"-.470"	P-453NX	P-11MM-COLLET	P-11MM-EXP
.472"	12.00	.469"-.489"	P-12MMNX	P-12MM-COLLET	P-12MM-EXP
Jobber			\$49.99	\$17.99	\$9.99



## .385" Top Expanding Pilots

• Expand up to .020" (.51mm) • Includes Collet & Expander

Size	mm	Range	Pilot	Collet	Expander
.236"	6.00	.233"-.253"	P-6MMSX	P-6MM-COLLET	P-1236-EXP
.250"	6.35	.247"-.267"	P-250SX	P-250-COLLET	P-1250-EXP
.256"	6.50	.253"-.273"	P-6.5MMSX	P-65MM-COLLET	P-6.5MM-EXP
.275"	7.00	.272"-.292"	P-7MMSX	P-7MM-COLLET	P-7MM-EXP
.281"	7.10	.278"-.298"	P-281SX	P-281-COLLET	P-281-EXP
.295"	7.50	.290"-.310"	P-7.5MMSX	P-281-COLLET	P-281-EXP
.312"	7.92	.309"-.329"	P-312SX	P-312-COLLET	P-343-EXP
.335"	8.50	.330"-.350"	P-8.5MMSX	P-343-COLLET	P-343-EXP
.343"	8.70	.340"-.360"	P-343SX	P-343-COLLET	P-343-EXP
.354"	9.00	.350"-.370"	P-9MMSX	P-375-COLLET	P-375-EXP
.375"	9.50	.372"-.392"	P-375SX	P-375-COLLET	P-375-EXP
.393"	10.00	.390"-.410"	P-10MMSX	P-10MM-COLLET	P-10MM-EXP
.406"	10.30	.403"-.433"	P-406SX	P-10MM-COLLET	P-10MM-EXP
.437"	11.00	.430"-.450"	P-11MMSX	P-11MM-COLLET	P-11MM-EXP
.453"	11.50	.450"-.470"	P-453SX	P-11MM-COLLET	P-11MM-EXP
.472"	12.00	.469"-.489"	P-12MMSX	P-12MM-COLLET	P-12MM-EXP
.500"	12.70	.497"-.517"	P-500SX	P-12MM-COLLET	P-12MM-EXP
Jobber			\$81.99	\$17.99	\$9.99

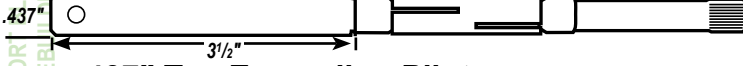

## .437" Top Expanding Pilots

• Expand up to .020" (.51mm) • Includes Collet & Expander

Size	mm	Range	Pilot	Collet	Expander
.236"	6.00	.233"-.253"	P-6MMKX	P-6MM-COLLET	P-1236-EXP
.275"	7.00	.272"-.292"	P-7MMKX	P-7MM-COLLET	P-7MM-EXP
.312"	7.92	.309"-.329"	P-312KX	P-312-COLLET	P-343-EXP
.343"	8.70	.340"-.360"	P-343KX	P-343-COLLET	P-343-EXP
.375"	9.50	.372"-.392"	P-375KX	P-375-COLLET	P-375-EXP
.393"	10.00	.390"-.410"	P-10MMKX	P-10MM-COLLET	P-10MM-EXP
.437"	11.00	.430"-.450"	P-11MMKX	P-11MM-COLLET	P-11MM-EXP
.453"	11.50	.450"-.470"	P-453KX	P-11MM-COLLET	P-11MM-EXP
Jobber			\$59.99	\$17.99	\$9.99



## .297" Top Expanding Pilots

• Expand up to .020" (.51mm) • Comes with Collet & Expander • High Speed Steel

Size	mm	Range	Pilot	Collet	Expander
.2165"	5.50	.213"-.233"	P-1216NX	P-216-COLLET	P-1216-EXP
.2362"	6.00	.233"-.253"	P-1236NX	P-6MM-COLLET	P-1236-EXP
.2500"	6.35	.247"-.267"	P-1250NX	P-250-COLLET	P-1250-EXP
.2810"	7.14	.278"-.298"	P-1281NX	P-281-COLLET	P-1281-EXP
.3120"	7.92	.309"-.329"	P-1312NX	P-312-COLLET	P-1312-EXP
.3149"	8.00	.312"-.332"	P-1315NX	P-312-COLLET	P-1315-EXP
Jobber			\$47.99	\$17.99	\$9.99

### tech tips

from the techexperts™

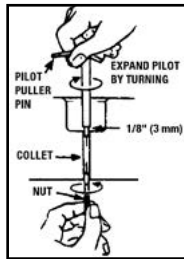

## Setting your expanding pilot

- 1 Select an expanding pilot that is the same diameter as the valve guide ID
- 2 Insert the pilot into the valve guide making sure that the expanding section of the pilot (collet) is completely within the valve guide. The pilot will not center properly and may be damaged if the collet extends outside of the valve guide.
- 3 Pilot shoulder should be about 1/8" above the valve guide
- 4 Turn the pilot while holding the nut at the opposite end. This will expand the collet and secure the pilot into position

**NOTE: DO NOT** use Expanding Pilots with multi-angle valve seat cutting systems (ie: 3-D Fast Cut)

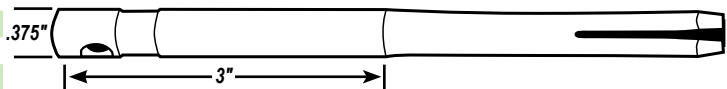

## .375" Top Leveling Split Pilots

- Centers deep in the valve guide
- Includes a groove for bearing-style stone holders
- Compensates for wear up to .010"
- Replace KO Lee

Size	Range in.	mm	OAL	Jobber	Order No.
5.0mm	.193"-.203"	4.90-5.84	5.25"	\$197.99	P-5MM-VNX
5.5mm	.213"-.223"	5.41-5.66	5.00"	182.99	P-5.5MM-VNX
6.0mm	.233"-.243"	5.91-6.17	5.00"	169.99	P-6MM-VNX
0.250"	.247"-.257"	6.27-6.52	5.25"	142.99	P-250-VNX
7.0mm	.273"-.283"	6.93-7.18	5.25"	172.99	P-7MM-VNX
0.312"	.299"-.319"	7.59-8.10	5.25"	147.99	P-312-VNX
8.0mm	.312"-.322"	7.92-8.17	5.25"	167.99	P-8MM-VNX
0.343"	.340"-.350"	8.63-8.88	5.25"	154.99	P-343-VNX
9.0mm	.351"-.361"	8.91-9.16	5.25"	147.99	P-9MM-VNX
0.375"	.372"-.382"	9.44-9.70	6.00"	154.99	P-375-VNX
0.437"	.434"-.444"	11.02-11.27	6.25"	154.99	P-437-VNX



## .375" Extended Length Expanding Pilots

• Expand up to .020" (.51mm) • Comes with Collet & Expander • High Speed Steel

Size	mm	Range	Pilot	Collet	Expander
.3120"	7.92	.309"-.329"	P-312NXL	P-312-COL	P-343-EXP
.3430"	8.71	.340"-.360"	P-343NXL	P-343-COL	P-343-EXP
.3750"	9.52	.372"-.392"	P-375NXL	P-375-COL	P-375-EXP
.4060"	10.31	.403"-.433"	P-406NXL	P-406L-COL	P-10MM-EXP
.4527"	11.50	.451"-.455"	P-453NXL	P-453L-COL	P-453-EXP
.4724"	12.00	.471"-.475"	P-12MMNXL	P-12MML-COL	P-12MM-EXP
.5000"	12.70	.497"-.517"	P-500NXL	P-500L-COL	P-12MM-EXP
Jobber			\$54.99	\$17.99	\$9.99

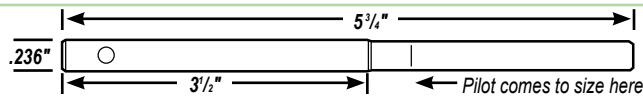

### .236" Top Tapered Carbide Pilots

- Less deflection under stress • Due to the brittle nature of carbide we can only warranty carbide pilots for size

Inch	mm	Order No.	Inch	mm	Order No.	Inch	mm	Order No.
.1559"	3.96	PCT-1560M	.1968"	5.00	PCT-1970M	.2560"	6.50	PCT-2560M
.1566"	3.98	PCT-1570M	.1980"	5.03	PCT-1980M	.2570"	6.53	PCT-2570M
.1575"	4.00	PCT-1575M	.2161"	5.49	PCT-2160M	.2578"	6.55	PCT-2580M
.1578"	4.01	PCT-1580M	.2170"	5.52	PCT-2170M	.2590"	6.58	PCT-2590M
.1759"	4.47	PCT-1760M	.2181"	5.54	PCT-2180M	.2598"	6.60	PCT-2600M
.1771"	4.50	PCT-1770M	.2350"	5.97	PCT-2350M	.2756"	7.00	PCT-2756M
.1779"	4.52	PCT-1780M	.2358"	5.99	PCT-2360M	.2759"	7.01	PCT-2760M
.1960"	4.98	PCT-1960M	.2370"	6.02	PCT-2370M	.2763"	7.02	PCT-2765M
Jobber	\$187.99		Jobber	\$187.99		.2771"	7.04	PCT-2770M
						Jobber	\$187.99	

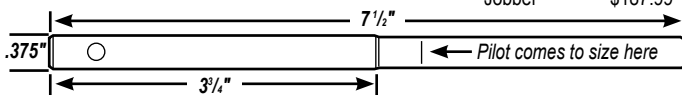

### .375" Top Tapered Carbide Pilots

Inch	mm	Order No.	Inch	mm	Order No.	Inch	mm	Order No.
.1575"	4.00	PCT-1575	.2370"	6.02	PCT-2370	.3150"	8.00	PCT-3150
.1771"	4.50	PCT-1770	.2598"	6.60	PCT-2600	.3422"	8.70	PCT-3420
.1968"	5.00	PCT-1970	.2756"	7.00	PCT-2756	.3433"	8.72	PCT-3430
.2165"	5.50	PCT-2165	.2759"	7.01	PCT-2760	.3440"	8.73	PCT-3440
.2173"	5.52	PCT-2170	.2763"	7.02	PCT-2765	.3728"	9.47	PCT-3730
.2355"	5.98	PCT-2355	.2771"	7.04	PCT-2770	.3740"	9.50	PCT-3740
.2362"	6.00	PCT-2362	.3122"	7.93	PCT-3120	.3750"	9.52	PCT-3750
Jobber	\$187.99		Jobber	\$187.99		Jobber	\$187.99	

**tech tips** When choosing a pilot, first decide if you need a "live" pilot (one from the techxperts™ which turns with the tooling) or "dead" pilot (one which remains stationary in the bore). Choose the top size, then the guide bore size.

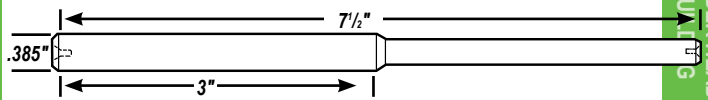

### .375" Top Serdi-Style (Live) Straight Carbide Pilots

- For applications where the pilot must turn with the tooling
- Solid carbide construction
- Due to the brittle nature of carbide, Goodson can only warranty these carbide pilots for size

mm	in	Order No.	mm	in	Order No.	mm	in	Order No.
3.99	.1571"	PCS-399	6.61	.2600"	PCS-661	8.02	.3157"	PCS-802
4.49	.1767"	PCS-449	6.99	.2752"	PCS-699	8.70	.3425"	PCS-870
4.50	.1771"	PCS-450	7.00	.2756"	PCS-700	8.72	.3433"	PCS-872
4.98	.1960"	PCS-498	7.01	.2760"	PCS-701	8.73	.3437"	PCS-873
4.99	.1964"	PCS-499	7.02	.2764"	PCS-702	8.74	.3440"	PCS-874
5.00	.1968"	PCS-500	7.03	.2768"	PCS-703	9.45	.3720"	PCS-945
5.48	.2157"	PCS-548	7.04	.2771"	PCS-704	9.46	.3724"	PCS-946
5.49	.2161"	PCS-549	7.90	.3110"	PCS-790	9.47	.3728"	PCS-947
5.50	.2165"	PCS-550	7.91	.3114"	PCS-791	9.48	.3732"	PCS-948
5.98	.2354"	PCS-598	7.92	.3118"	PCS-792	9.49	.3736"	PCS-949
5.99	.2358"	PCS-599	7.93	.3122"	PCS-793	9.51	.3744"	PCS-951
6.00	.2362"	PCS-600	7.95	.3130"	PCS-795	9.52	.3748"	PCS-952
6.01	.2368"	PCS-601	7.99	.3146"	PCS-799	Jobber	\$189.99	
6.50	.2559"	PCS-650	8.00	.3150"	PCS-800			
6.59	.2594"	PCS-659	8.01	.3154"	PCS-801			
Jobber	\$189.99		Jobber	\$189.99				

## tech tips

from the techxperts™

We get asked from time to time why Goodson carries so many sizes and styles of pilots.

The short answer is, "They're needed."

To expand on that ... The pilot is possibly the most important tool you can have. Without the right size pilot, you won't be able to do accurate work.

Most of us probably think of that in terms of Top and Bottom Size, but there's another dimension that's becoming more important every day. The pilot's top length.

You've probably worked on (or at least seen) heads with deeply set valves. This is especially common in diesel applications. Some of them are set so deeply that a standard pilot just won't cut it. You need a pilot that extends above the deck while still being fully seated in the guide in order to perform top quality seat work.

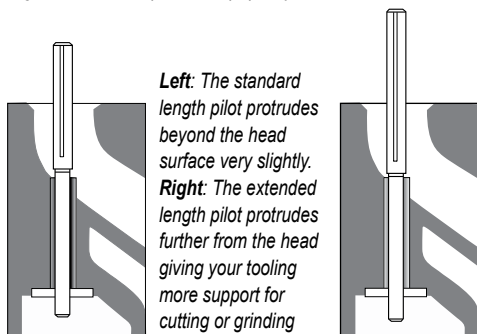

**Left:** The standard length pilot protrudes beyond the head surface very slightly.  
**Right:** The extended length pilot protrudes further from the head giving your tooling more support for cutting or grinding

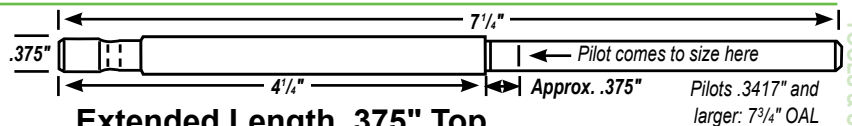

### Extended Length .375" Top Solid-Tapered High Speed Steel Pilots

Inch	mm	Order No.	Inch	mm	Order No.	Inch	mm	Order No.
.2165"	5.50	P-5217NL	.3115"	7.91	P-5311NL	.3447"	8.75	P-5344NL
.2173"	5.52	P-5218NL	.3125"	7.93	P-5312NL	.3457"	8.78	P-5345NL
.2362"	6.00	P-5236NL	.3135"	7.95	P-5313NL	.3730"	9.47	P-5373NL
.2370"	6.02	P-5237NL	.3145"	7.98	P-5314NL	.3740"	9.50	P-5374NL
.2598"	6.60	P-5260NL	.3150"	8.00	P-5315NL	.3750"	9.52	P-5375NL
.2606"	6.62	P-5261NL	.3157"	8.02	P-5316NL	.3760"	9.55	P-5376NL
.2755"	7.00	P-5275NL	.3417"	8.68	P-5341NL	.3820"	9.70	P-5382NL
.2763"	7.02	P-5276NL	.3427"	8.70	P-5342NL	Jobber	\$57.99	
.3105"	7.88	P-5310NL	.3437"	8.73	P-5343NL			
Jobber	\$57.99		Jobber	\$57.99				

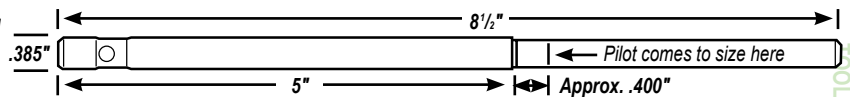

### Extended Length .385" Top Solid-Tapered High Speed Steel Pilots

Inch	mm	.385" Top	Inch	mm	.385" Top	Inch	mm	.385" Top
.2755"	7.00	P-5275SL	.3125"	7.93	P-5312SL	.3457"	8.78	P-5345SL
.2756"	7.00	P-5276SL	.3135"	7.96	P-5313SL	.3460"	8.79	P-5346SL
.2775"	7.05	P-5277SL	.3145"	7.98	P-5314SL	.3720"	9.45	P-5372SL
.2785"	7.07	P-5278SL	.3437"	8.73	P-5343SL	.3730"	9.47	P-5373SL
.2795"	7.10	P-5279SL	.3447"	8.75	P-5344SL	.3740"	9.50	P-5374SL
Jobber	\$89.99		Jobber	\$89.99		.3750"	9.52	P-5375SL
						Jobber	\$89.99	

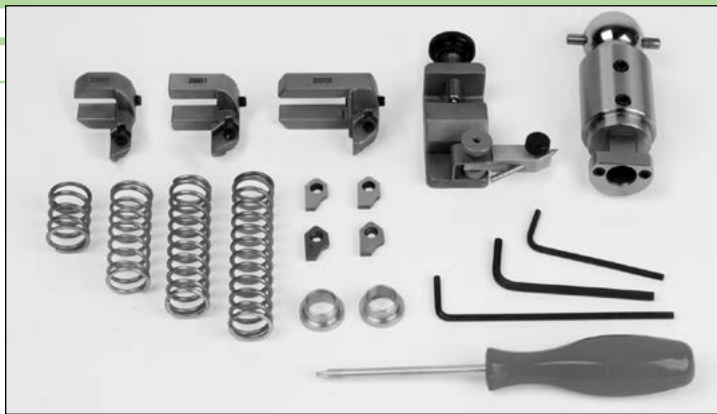

Ball Heads

## 3-D Fast Cut™ Starter Kits

- Can be used with your existing pilots • Ball heads are available to fit most common seat grinder pilots • Choose from over 100 3-angle blade profiles on pages 6-9
- Fully compatible with most popular 3-angle cutting systems including Kwik-Way, Peterson, Rottler, Serdi, Sunnen, T&S, Winona Van Norman, Newen, etc.

Description	Fits Pilot	Jobber	Order No.	Includes
<b>Fits Pilot Size</b>	.375" / 9.53mm	\$999.99	3D-375-KIT	
(see page 1 for our selection of pilots)	.385" / 9.78mm	999.99	3D-385-KIT	
	.390" / 9.90mm	999.99	3D-390-KIT	
	.437" / 11.10mm	999.99	3D-437-KIT	
<b>Ball Head Standard</b>	.375" / 9.53mm	219.99	3D-BH375	x
3/8" channel fits most	.385" / 9.78mm	219.99	3D-BH385	x
3-angle systems such as Serdi, WVN, KW, etc.	.390" / 9.90mm	219.99	3D-BH390	x
	.437" / 11.10mm	219.99	3D-BH437	x
<b>Ball Head Extended</b>	.375" / 9.53mm	249.99	3D-BH375L	
Length 3.80" long	.385" / 9.78mm	249.99	3D-BH385L	
<b>Ball Head Wide Body</b>	.375" / 9.53mm	369.99	3D-BH375W	
4.0625" long	.385" / 9.78mm	369.99	3D-BH385W	
<b>Serdi-Style Tool Bodies</b>	Use with Serdi-style pilots (page 2)			
4" long	Standard .375" / 9.53mm	317.99	SER-5100	
	Large Body .375" / 9.53mm	394.99	SER-5300	
<b>Tip Holders</b>	.709" - 1.181" / 18-30mm Range	169.99	3D-2000	x x x x
	1.02" - 1.653" / 26-42mm Range	169.99	3D-2001	x x x x
	1.575" - 2.362" / 40-60mm Range	169.99	3D-2002	x x x x
<b>Tip Holders-Wide Body</b>	1.575" - 2.362" / 40-60mm Range	239.99	3D-2003	
	2.385" - 3.150" / 58-80mm Range	249.99	3D-2004	
<b>Cutters</b>	45°/1.0mm	29.99	FT-45039V1	x x x x
	45°/1.3mm	29.99	FT-45051V1	x x x x
more on pages 6 - 9	45°/1.5mm	29.99	FT-45059V1	x x x x
	45°/1.9mm	29.99	FT-45075V1	x x x x
<b>Tool Setting Fixture</b>		139.99	3D-TSFA	x x x x
Cutter Blade Mounting Screw (Buy 6 or more, only \$3.99 ea.)		4.99	FT-SCREW	x x x x
<b>Blade Wrench</b>		9.99	FT-WRENCH	x x x x
<b>Automotive Spring Set (4 Pc.)</b>		24.99	3D-SS4	x x x x
<b>Bushing Set (1 pair)</b>	.375"	8.99	3D-DB7	x
	.385"	8.99	3D-DB6	x x
	.437"	8.99	3D-DB5	x
<b>Ball Head</b>	#3 Morse Taper Driver	349.99	3D-CM3	
<b>Drive Adaptors</b>	#4 Morse Taper Driver	349.99	3D-CM4	
	Bridgeport & DCM Driver	299.99	3D-3/4SS	
	Sunnen Early Style Driver	314.99	3D-SUN	
<b>3-D Fast Cut™ Accessories</b>				
Lift Clip for Spring Pad Cutters (page 10)		\$21.99	3D-CLIP	
Replacement 3/8" Hex Key		1.29	3D-1/8	x x x x
Replacement 2.5mm Hex Key		1.29	3D-2.5	x x x x
Replacement 3/32" Hex Key		1.29	3D-3/32	x x x x
Replacement Screws for NWN Ball Head Base (5) - metric		1.99	MGA-4X5MM	
Replacement Screw for 3D Ball Head Base - SAE 10x32		4.99	3D-BH1032	
Adjusting Screw for Holder #3D-2000, OAL: .395" / 10mm		5.49	3D-2000-S	
Adjusting Screw for Holder #3D-2001, OAL: .475" / 12mm		5.49	3D-2001-S	
Adjusting Screw for Holder #3D-2002, OAL: .625" / 15.9mm		5.49	3D-2002-S	

See page 5 for our Valve Seat Removal Tooling for the 3-D Fast Cut™ System

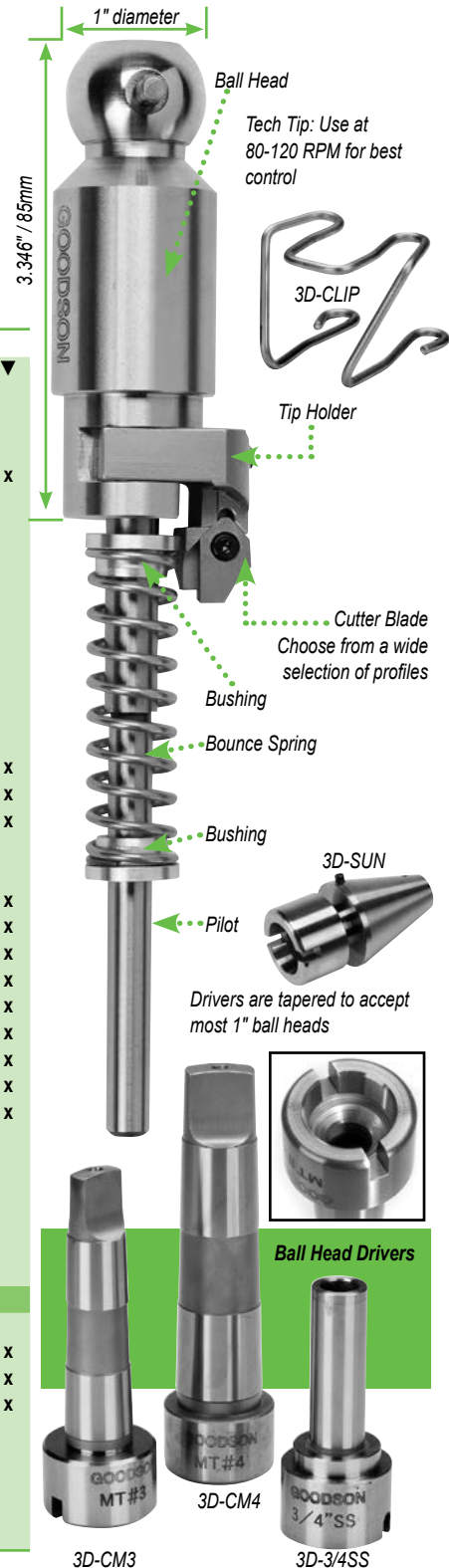

## tech tips Choosing the Ball Head Driver

from the techxperts™

Choose the correct Ball Head Driver for your machine by finding your pilot size in the charts on pages 4 & 5 (Example if you have .375" top pilots you will use the 3D-BH375; if your pilot size is .236", you will use 3D-BH236, etc.). Goodson 3-D tooling is available in kits, incorporating all of the necessary pieces. You can also purchase items on an individual basis. Goodson carries many accessories and optional equipment for you to choose from.

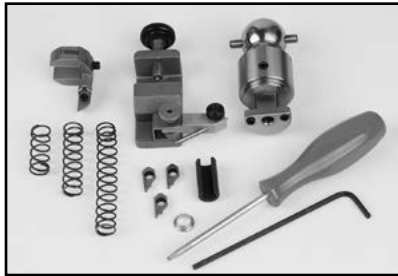

3-D FAST CUT™ SYSTEM

3DH-1995 3DH-1999M

3DH-1995 3DH-1999M

3DH-1995 3DH-1999M

3DH-1995 3DH-1999M

3DH-1995 3DH-1999M

3DH-1995 3DH-1999M

3DH-1995 3DH-1999M

3DH-1995 3DH-1999M

3DH-1995 3DH-1999M

3DH-1995 3DH-1999M

### 3-D Fast Cut™ System Micro Ball Head Tooling

• Fits the same 1" ball head driver

Description	Jobber	Order No.	
Micro Ball Head Starter Kit	\$699.99	3D-236-KIT	▼
3D Ball Head for .236"/6mm Pilot (2.56"L)	209.99	3D-BH236	x
Micro Cutter Tips 45°/1.0mm	39.99	FTM-185	x
See pg. 7 45°/1.0mm	39.99	FTM-187	x
for profiles 39°/1.0mm	39.99	FTM-188	x
90° (For counterboring*)	39.99	FTM-190	
82° Radius Cutter	39.99	FTM-82R6B-HP	
Tip Holders .550"-.984" Range	179.99	3DH-1999M	x
.551"-.850" Range	179.99	3DH-1995	
Bounce Springs Short 1.050" / 26.7mm	11.99	3D-BS1	x
.340" ID Medium 1.540" / 39.2 mm	11.99	3D-BS3	x
.420" OD Long 2.550" / 64.8 mm	11.99	3D-BS2	x
Bounce Spring Bushing	8.49	3D-BB1	x
Bounce Spring Spacer 22mm long	29.99	3D-BB2	x
<b>3-D Fast Cut™ Accessories</b>			
Replacement 2.5mm Hex Key	\$1.29	3D-2.5	x
Replacement Screws for Ball Head	4.99	3D-BH1032	
Cutter Blade Mounting Screw (6 or more, \$3.99 ea.)	4.99	FT-SCREW	x
Blade Wrench	9.99	FT-WRENCH	x
Tool Setting Fixture	139.99	3D-TSFA	x
Setting Micrometer for Counterbore Cutting*	219.99	3DM-236	

#### .236" Top Carbide Pilots

Inch	mm	Order No.	Inch	mm	Order No.
.1559"	3.96	PCT-1560M	.2350"	5.97	PCT-2350M
.1566"	3.98	PCT-1570M	.2355"	5.99	PCT-2360M
.1575"	4.00	PCT-1575M	.2370"	6.02	PCT-2370M
.1578"	4.01	PCT-1580M	.2560"	6.50	PCT-2560M
.1759"	4.47	PCT-1760M	.2570"	6.53	PCT-2570M
.1771"	4.50	PCT-1770M	.2578"	6.55	PCT-2580M
.1779"	4.52	PCT-1780M	.2590"	6.58	PCT-2590M
.1960"	4.98	PCT-1960M	.2598"	6.60	PCT-2600M
.1968"	5.00	PCT-1970M	.2756"	7.00	PCT-2756M
.1980"	5.03	PCT-1980M	.2759"	7.01	PCT-2760M
.2161"	5.49	PCT-2160M	.2763"	7.02	PCT-2765M
.2170"	5.52	PCT-2170M	.2771"	7.04	PCT-2770M
.2181"	5.54	PCT-2180M			

Jobber \$187.99

Jobber \$187.99



3-D FAST CUT™ SYSTEM

### Valve Seat Removal Tooling

- Fits most popular 3-angle cutting tools including our popular 3-D Fast Cut™ System, Kwik-Way, Peterson, Rottler, Serdi, T&S, Winona Van Norman, Newen, etc.
- Use to relieve press fit for easier seat removal
- Requires a minimum of 2 cuts
- For precise set up use **MGA-MIC**
- Tip Holders include one cutting tip and mounting screw (see chart below)
- Replacement tips and screws sold separately
- Ball Head and Drive Tools sold separately (see page 4)

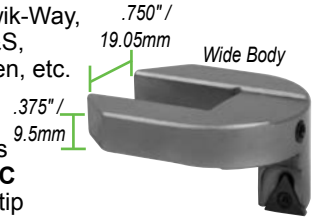
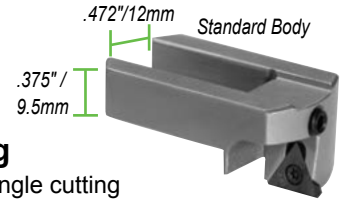

Description	Replacement Tip	Jobber	Order No.
Tip Holders	3DB-1999i	\$229.99	3D-1999C
	3DB-250	229.99	3D-2000C
	3DB-250	229.99	3D-2001C
	3DB-250	229.99	3D-2002C
Wide Body	3DB-250	319.99	3D-2003C
	3DB-250	329.99	3D-2004C
Replacement Tip		39.99	3DB-1999i
		37.99	3DB-250
Replacement Screw for 3DB-1999i		13.99	3DB-1999S
	for 3DB-250	11.99	3DS-SCREW

#### Cutting Range with Pilot Size

Holder	.236" Top	.375" Top	.385" Top	.437" Top
3D-1999C	0.960"-1.225"	1.095"-1.360"	1.105"-1.360"	1.157"-1.360"
3D-2000C	1.056"-1.480"	1.194"-1.480"	1.206"-1.480"	1.264"-1.480"
3D-2001C	—	1.376"-2.000"	1.386"-2.000"	1.450"-2.000"
3D-2002C	—	1.524"-2.460"	1.544"-2.460"	1.610"-2.460"
3D-2003C	—	1.680"-2.400"	1.680"-2.400"	—
3D-2004C	—	2.280"-3.200"	2.280"-3.200"	—

### 3-D Fast Cut Setting Micrometers

- Accurate to .001"
- Standard micrometer uses tapered .375" Pilot to match your ball head (sold separately, page 1)
- Use to set cutting diameter of 90° carbide cutters when modifying counterbores

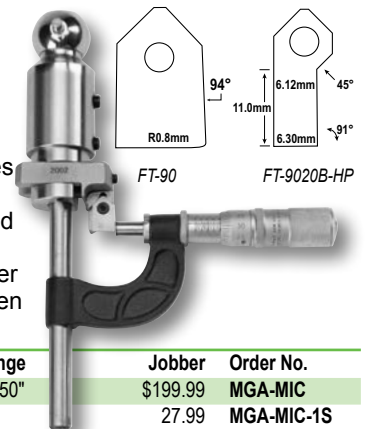

Description	Cutting Range	Jobber	Order No.
Standard Micrometer	1.000" - 2.650"	\$199.99	MGA-MIC
Setting Standard		27.99	MGA-MIC-1S
90° Cutter		29.99	FT-90
90° Cutter		39.99	FT-9020B-HP

### Micro Setting Micrometer

- Use with .236" Pilot (PCT-2360M)

Description	Cutting Range	Jobber	Order No.
Micro Micrometer	0.236" - 2.000"	\$219.99	3DM-236
90° Micro Cutter		39.99	FTM-190
Pilot		187.99	PCT-2360M

CYLINDER HEAD REBUILDING

CLEANING, ASSEMBLY & SAFETY

SHORT BLOCK REBUILDING

FLYWHEEL GRINDING

CRANKSHAFT/ MISCELLANEOUS TOOLS & SUPPLIES

BRAKE & TIRE CHANGING TOOLS

MEASURING TOOLS

V-TWIN & METRIC HARD PARTS

# Mondello Signature Series Cutter Blades

CYLINDER HEAD  
REBUILDING

CLEANING,  
ASSEMBLY & SAFETY

SHORT BLOCK  
REBUILDING

CRANKSHAFT/  
FLYWHEEL GRINDING

MISCELLANEOUS  
TOOLS & SUPPLIES

BRAKE & TIRE  
CHANGING TOOLS

MEASURING  
TOOLS

V-TWIN & METRIC  
HARD PARTS

## Diamond Hand Files

- Choose between 360 & 600 grit
- Use for fine touch-ups on your FT Blades

Description	Jobber	Order No.
Diamond File Set -		
1-360 grit & 1-600 grit	\$62.99	DFS-2
600 Grit Files ( 2-pack)	62.99	DFS-6

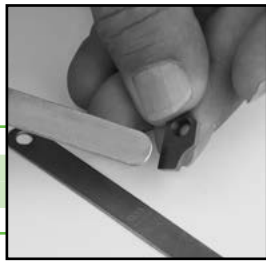

## Add 10 to 20 CFM to Cylinder Heads

Designed to increase airflow by as much as 20 CFM, these cutters are intended for certain applications. Generally you should use intake cutters on intakes and exhaust on exhausts, but as with most things, there's always an exception. Experiment to find the right combination for you and your customers.



All Cutters This Page Jobber \$39.99 each

**I** Intake

**E** Exhaust

**S** Specialty

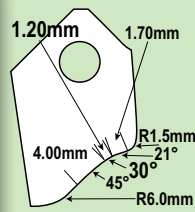

**I** IFT-30B-HP

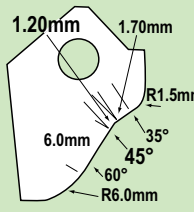

**E** IFT-4560B-HP

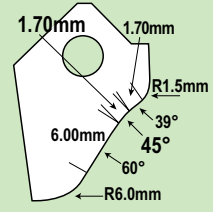

**I** IFT-45B-HP

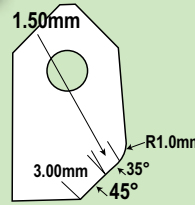

**S** KFT-3545

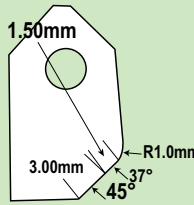

**S** KFT-3745

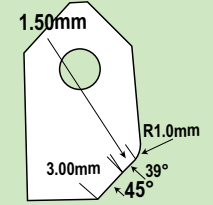

**S** KFT-3945

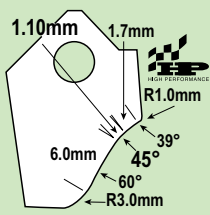

**I** IFT-4539B-HP

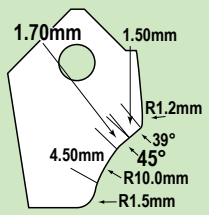

**I** IFT-4529B-HP

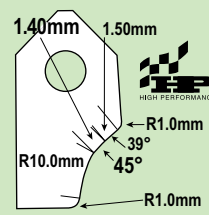

**I** IFT-4524-HD

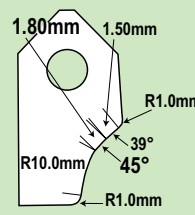

**E** IFT-4524A-HD

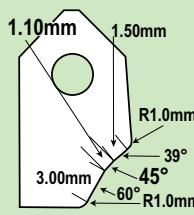

**E** IFT-4560-HD

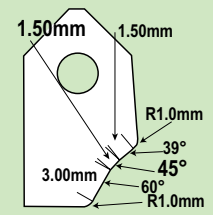

**I** IFT-4560A-HD

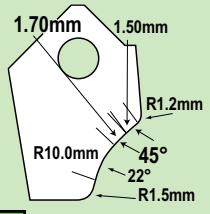

**I** IFT-4522B-HP

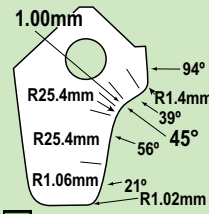

**E** IFT-4556B-HP

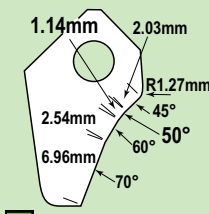

**E** EFT-5060B-HP

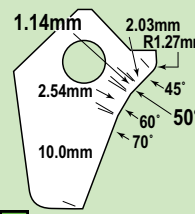

**E** EFT-5061B-HP

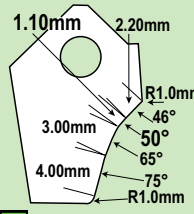

**E** IFT-5065B-HP

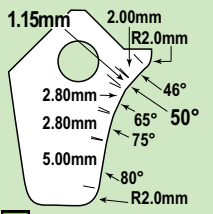

**E** EFT-5046B-HP

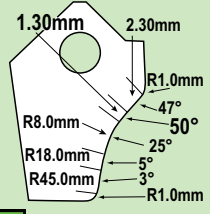

**E** IFT-5025B-HP

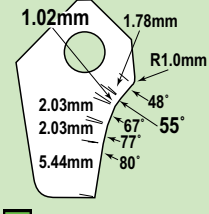

**E** EFT-5567B-HP

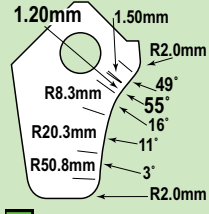

**E** EFT-5557B-HP

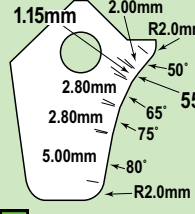

**E** EFT-5550B-HP

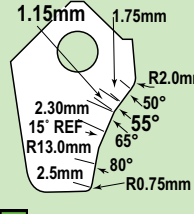

**E** EFT-5565B-HP

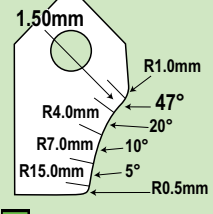

**E** KRT-447

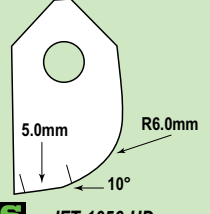

**S** IFT-1056-HD

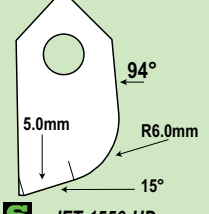

**S** IFT-1556-HD

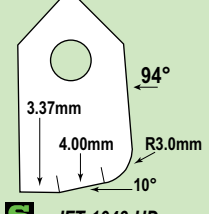

**S** IFT-1043-HD

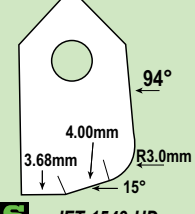

**S** IFT-1543-HD

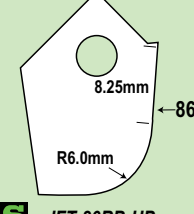

**S** IFT-86RB-HP

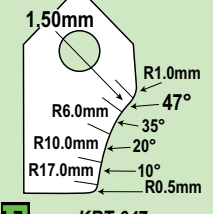

**E** KRT-647

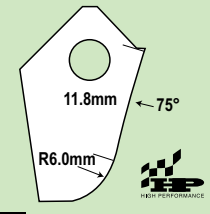

**S** IFT-75R6B-HP

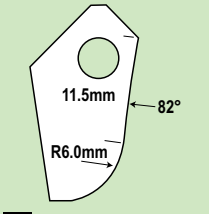

**S** IFT-82R6B-HP

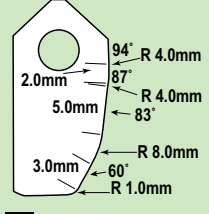

**E** RBP-RR4

## 3-Piece High Performance Cutter Set



- Increase flow & improve horsepower with this set
- Order No. IFT-HP-SET
- Jobber \$99.99



IFT-4539B-HP - Intake

IFT-75R6B-HP - Follow up Intake

IFT-4524-HD - Exhaust

# Radius Profile Seat Cutter Blades

American-Made

All Cutter Blades on this page Jobber \$39.99

## Universal Cutter Blade Sharpener

- Keep your multi-angle cutters sharp with this universal sharpening fixture
- Balanced ball-bearing fan-cooled electric motor
- Variable angle plus/minus 15°
- 1 3/4" dia. Diamond Lap
- Lighted on/off rocker switch
- Safety catch tray with splash guard for lapping oil
- Available in 115V, 60 Hz and 220V 50 Hz



Description	Jobber	Order No.	Incl.
Sharpener Kit 115V	\$1,049.99	3D-SHARP	▼
Sharpener Kit 230V	1,099.99	3D-SHARP-220	▼
3D Cutter Holder	34.79	3D-HOLDER	x x
Diamond Lap	188.99	LP-RFA	x x
Dressing Stick	9.49	LP-DS	x x
4 oz. Lapping Oil with Dauber	10.49	LP-LO-4	x x

CYLINDER HEAD  
REBUILDING

CLEANING,  
ASSEMBLY & SAFETY

SHORT BLOCK  
REBUILDING

CRANKSHAFT/  
FLYWHEEL GRINDING

MISCELLANEOUS  
TOOLS & SUPPLIES

BRAKE & TIRE  
CHANGING TOOLS

MEASURING  
TOOLS

V-TWIN & METRIC  
HARD PARTS

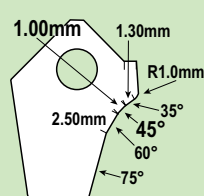

FT-069B-HP

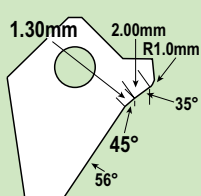

FT-081B-HP

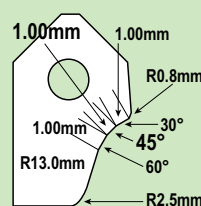

FT-5118A-HP

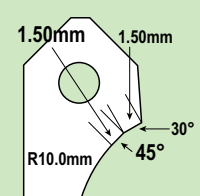

FT-5119A-HP

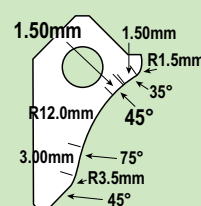

FT-003B-HP

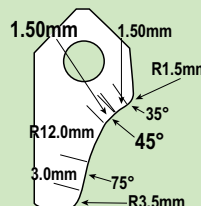

FT-004B-HP

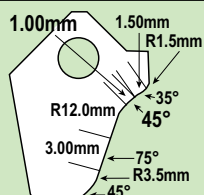

FT-005B-HP

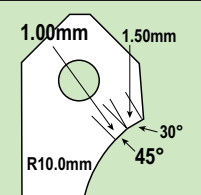

FT-5120A-HP

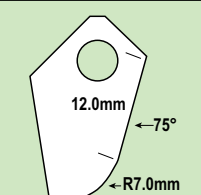

FT-002B-HP

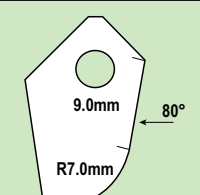

FT-033B-HP

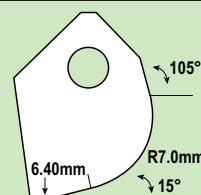

FT-077B-HP

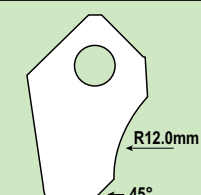

FT-084B-HP

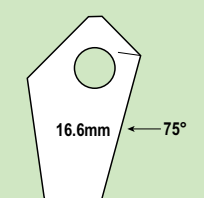

FT-085B-HP

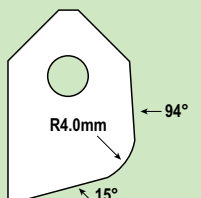

FT-5121A-HP

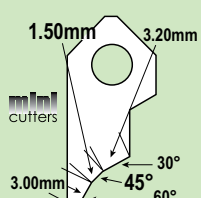

FT-213B-HP

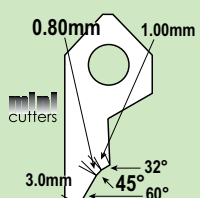

FT-215B-HP

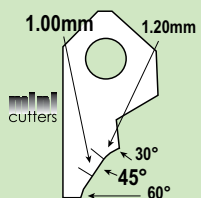

FT-4028B-HP

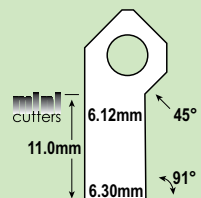

FT-9020B-HP

sized for **diesel**  
More Diesel Cutters, page 9

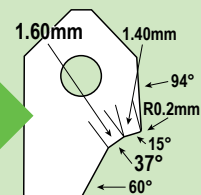

FT-37063S60

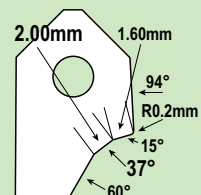

FT-37079S60

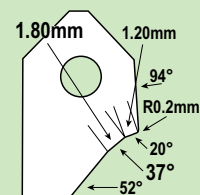

FT-37071S52

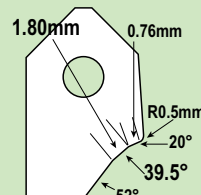

FT-39570T1

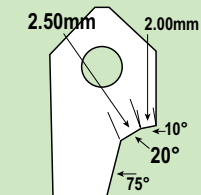

FT-20098S1

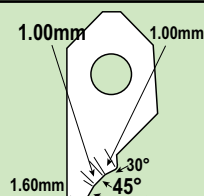

FTM-185

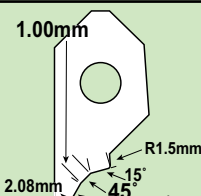

FTM-187

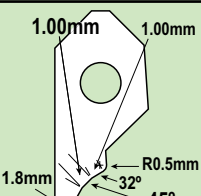

FTM-188

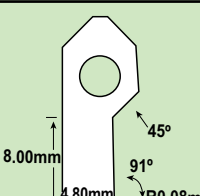

FTM-190

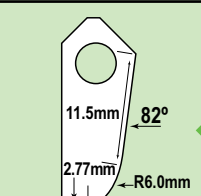

FTM-82R6B-HP

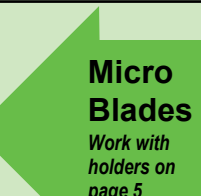

**Micro  
Blades**  
Work with  
holders on  
page 5

# 3-D Multi-Angle Seat Cutter Blades

All Blades This Page Jobber \$29.99

CYLINDER HEAD  
REBUILDING

CLEANING,  
ASSEMBLY & SAFETY

SHORT BLOCK  
REBUILDING

CRANKSHAFT/  
FLYWHEEL GRINDING

MISCELLANEOUS  
TOOLS & SUPPLIES

BRAKE & TIRE  
CHANGING TOOLS

MEASURING  
TOOLS

V-TWIN & METRIC  
HARD PARTS

					<b>Contact Goodson to Learn How to Have Custom Profiles Made</b>

45° Seat Angle Cutter Blades

30° Seat Angle Cutter Blades

**Single Angle Valve Seat Cutter Blades Jobber \$29.99 ea.**

<b>FT-15</b>	<b>FT-20</b>	<b>FT-25</b>	<b>FT-30</b>	<b>FT-35</b>	<b>FT-37</b>
<b>FT-39</b>	<b>FT-45</b>	<b>FT-50</b>	<b>FT-52</b>	<b>FT-55</b>	<b>FT-60</b>
<b>FT-65</b>	<b>FT-70</b>	<b>FT-75</b>	<b>FT-82</b>	<b>FT-90</b>	<b>FT-R5</b>
<b>FT-37063S60</b>					
	<b>FT-37063S60</b>	<b>FT-37079S60</b>	<b>FT-37071S52</b>	<b>FT-39570T1</b>	<b>FT-20098S1</b>

**sized for diesel**  
**Diesel Blades**  
**Jobber \$39.99**



**Wake up Your Diesel!**

- Increase Low Lift Air Flow
- Increase Torque
- Increase Horsepower

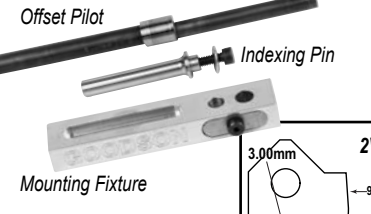

**Diesel Relief Tooling**

- Use with your seat and guide machine or Bridgeport Mill equipped with a multi-angle seat cutting system • Developed for Goodson by Joe Mondello Racing Engines
- Use for 6.0L & 7.3L Ford, 12 Valve, 5.9L Cummins & 6.6L Duramax diesel engines
- For 2-Valve and 4-Valve heads
- Complete kit includes the Mounting Fixture, Offset Pilot, Indexing Pin & a Radius Cutter
- This tool is only for use with radius cutters BSS-20CC and BSS-45CC

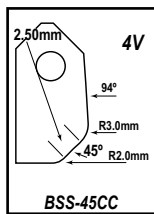
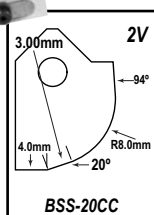

Description	Jobber	Order No.	Incl.
7mm Diesel Relief Tool Kit	\$169.99	DVRT-7MM-KIT	▼
8mm Diesel Relief Tool Kit	169.99	DVRT-8MM-KIT	▼
20CC Radius Cutter for 2-Valve Heads	39.99	BSS-20CC	x
45CC Radius Cutter for 4-Valve Heads	39.99	BSS-45CC	x

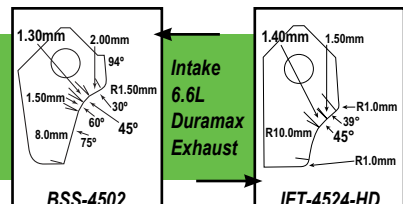
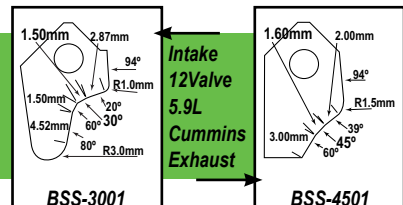
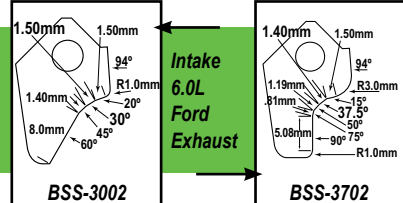
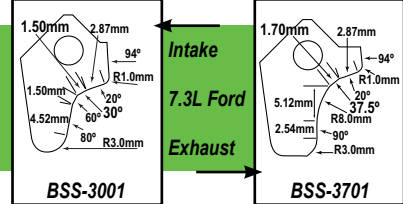

**new**

**Black Smoke Series for High Performance Diesel Engines**

Developed for Goodson by Joe Mondello Racing Engines. These cutters are designed to be used with your 3-D Fast Cut or other multi-angle tooling.

Jobber \$39.99 ea.



CYLINDER HEAD REBUILDING  
 CLEANING, ASSEMBLY & SAFETY  
 SHORT BLOCK REBUILDING  
 CRANKSHAFT/FLYWHEEL GRINDING  
 MISCELLANEOUS TOOLS & SUPPLIES  
 BRAKE & TIRE CHANGING TOOLS  
 MEASURING TOOLS  
 V-TWIN & METRIC HARD PARTS

... another satisfied customer



"At Warrior Racing we invested in the VM-42 fixture and 3D Fast Cut tooling to insure our valve seat angles are concentric to create the necessary air flow for our 10,000 HP Top Fuel Engines."

- Bob Peck, Warrior Racing, Tipp City, OH, Goodson customer since 2011

CYLINDER HEAD REBUILDING

CLEANING, ASSEMBLY & SAFETY

SHORT BLOCK REBUILDING

CRANKSHAFT/ FLYWHEEL GRINDING

MISCELLANEOUS TOOLS & SUPPLIES

BRAKE & TIRE CHANGING TOOLS

MEASURING TOOLS

V-TWIN & METRIC HARD PARTS

3-D FAST CUT™ SYSTEM

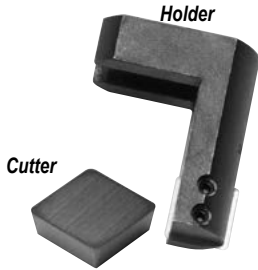

### 3-D Fast Cut Adjustable Spring Pad Cutters

- No need to change tooling, just change the tool holder and start cutting spring pads
- Works with all popular 3-angle cutting systems
- Square blades are indexable and replaceable
- Tool holder includes one blade

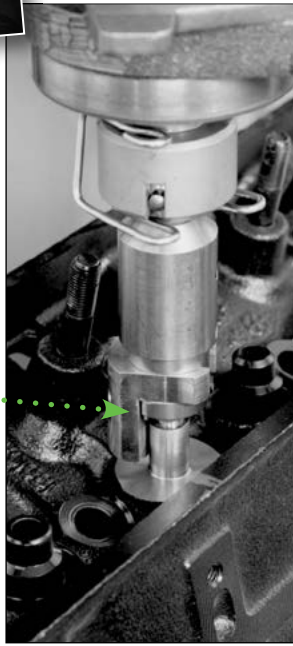

3D-SUN



Tool Holders			
Blade Size	Application	Jobber	Order No.
3/8" / 9.53mm	All except Sunnen®	\$184.99	SPC-375
1/2" / 12.70mm	All except Sunnen®	184.99	SPC-500
Sunnen Drive Adaptor		314.99	3D-SUN
3/8" / 9.53mm	Sunnen®	174.99	SUN-375
Lift Clip (fit all except OE Sunnen®)		21.99	3D-CLIP
Replacement Carbide Cutters (for all holder styles above)			
3/8" / 9.53mm		\$ 16.99	SPCI-375
1/2" / 12.70mm		16.99	SPCI-500

**tech tips** **PROBLEM:** I use a Sunnen® seat and guide machine. I'm having trouble controlling the spring pad cutting from the techxperts™ process. What do you have that will help?

**SOLUTION:** Goodson has designed a drive adaptor specifically for Sunnen® seat and guide machines with early style tooling. With the OE Sunnen® tooling, there is no way to hold back on the cut. The design of our 3D-SUN drive adaptor incorporates a groove in the drive adaptor so you can use the 3D-CLIP to connect the drive adaptor and the ball head for positive control. It moves when you do.

## Conversion Calculator

We've tried to convert as many SAE measurements to Metric (and vice versa) as possible. In some cases there hasn't been enough room.

If you need to convert a measurement, here are the formulas:

Starting Measurement	Conversion Formula	Converted Measurement
Inches (in)	# Inches x 25.4	Millimeters (mm)
Feet (ft)	# Feet x .0348	Meters (m)
Millimeters (mm)	# Millimeters ÷ 25.4	Inches (in)
Fahrenheit (F)	(5÷9) x (F - 32)	Celsius (C)
Celsius (C)	(9÷5) x (C + 32)	Fahrenheit (F)

Visit [www.goodson.com/blog/2014/04/22/metric-conversion-calculators/](http://www.goodson.com/blog/2014/04/22/metric-conversion-calculators/) for interactive calculators - just plug your numbers into the correct calculator for instant results

### Remove material and recontour bowls with the GOODSON 3-D Fast Cut™ Bowl Profiler

- Machine seats & bowls on a pair of V8 heads in about 40 minutes
- Remove material to recontour cylinder head bowl areas and unshroud valves in combustion chambers
- Blades can be modified using our sharpener (see page 7)
- Will not work with Sunnen® Ball Heads

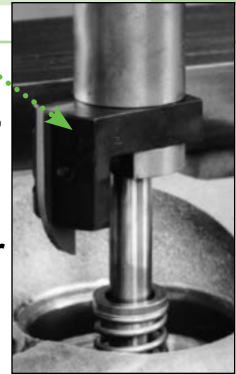
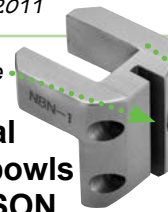

Holder Diameter Range	Jobber	Order No.
1.25"-1.87" / 32-48mm	\$166.49	NBN-1
1.57"-2.13" / 40-54mm	166.49	NBN-2

Blades sold separately

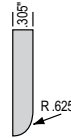

NBN-5  
\$74.99

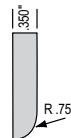

NBN-6  
\$74.99

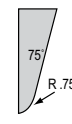

NBN-12  
\$109.99

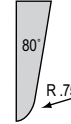

NBN-14  
\$109.99

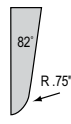

NBN-15  
\$109.99

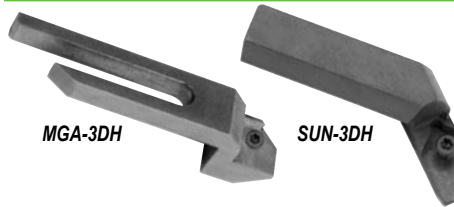

MGA-3DH

SUN-3DH

MGA-3DH

Use these Mini Holders with Mini Cutters below

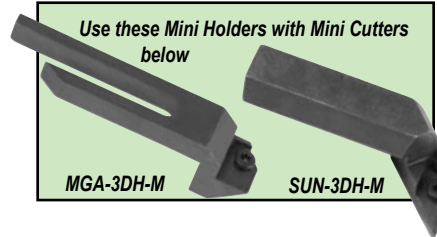

MGA-3DH-M

SUN-3DH-M



SUN-3DH

### Convert your Sunnen® or Mira® brazed cutters to 3-D with this simple holder

This blade holder allows you to mount premium, replaceable carbide cutters on your existing MIRA® and Sunnen® ball-type tool holders. Choose from our wide selection of replaceable cutters, previously only available for 3-D Fast Cut™ or similar seat cutting systems.

Description	Jobber	Order No.
Standard Cutter	Mira® \$169.99	MGA-3DH
Holders	Sunnen® VSC-Series 174.99	SUN-3DH
Mini Cutter	Mira® 169.99	MGA-3DH-M
Holders	Sunnen® 174.99	SUN-3DH-M
Mini Cutters	30°/45°/60° 39.99	FT-213B-HP
	32°/45°/60° 39.99	FT-215B-HP
view profiles	30°/45°/60° 39.99	FT-4028B-HP
on page 7	45°/90° 39.99	FT-9020B-HP
Replacement Screw (Buy 6 or more, only \$3.99 each)	4.99	FT-SCREW

# Valve Seat Work

## Precision Valve Seat Run-Out Gauge

- Use with .375" Top Pilot
- Measure run-out to .0001" directly from the valve seat
- Locked to the pilot
- Dial indicator remains stationary while rotating contact pointer
- Range: .800" to 2.500" diameter
- Order No. **SCG-375**
- Jobber \$649.99



Measure run-out to .0001" directly from valve seat



## Valve Seat Run-Out Gauge

- Hardened guide bushings & contact pilot
- Quick thumb screw set-up
- Jeweled bearing indicator reads to  $\pm .050"$  with .001" precision
- Range: 1.00"-2.50"

Pilot Size	Jobber	Order No.
.375"	\$149.99	VSG-375
.385"	149.99	VSG-385

Buy 6 or more cans SBF-16 and save 10% off jobber



## Check valve to seat contact with any of these layout fluids

Description	Color	Jobber	Order No.
Layout Fluid Markers	Blue	\$9.99	VBF-2
2 oz. / 59 mL	Red	9.99	VRF-2
Layout Fluid 4oz. / 118mL	Blue	9.99	VBF-4
(includes brush)	Red	9.99	VRF-4
Prussian Blue Machining Paste	3/4 oz. / 22mL	8.49	PB-75
Spray Bluing Fluid (Aerosol)*	Blue	9.99	SBF-16*

\*Hazardous Goods Fees Apply When Shipped by Air



## Valve and Seat Scribe Tool

- Fits .375" Top Pilot
- Kit includes: tool body, scribe, 1 pilot sleeve, and 6.6mm, 8.0mm, 5/16", 1 1/2" and 3/8" valve stem sleeves
- Sleeves fit tool body to valve stems & pilots
- Use valve to set point then scribe seat with inner & outer radii
- Grind seat top & throat to match face precisely
- Order No. **ST-30-BD** Jobber \$34.99



## Machine valve seats to a mirror-like finish with Valve Seat Machining Aid

- Universal - works with any type of cylinder head machining center
- Use full strength
- Safe for metal surfaces
- Works with mineral-based cutting oils, not water based
- Quart (946mL)
- Order No. **PF-2020**
- Jobber \$44.99

Buy 6 or more cans of Cutting & Tapping Fluid and SAVE 10% off Jobber



## Cut through even the hardest metals with Cutting & Tapping Fluid

- Spray clings to the surface of the tool to prolong tool life
- Ideal for stainless steel, high nickel alloys, titanium and more
- Use for reaming, seat cutting and CBN cutting
- Aerosol\* • Order No. **CTF-14** Jobber \$12.49

\*Hazardous Goods Fees Apply When Shipped by Air



## Minnesota Fast Freeze instantly chills seats and guides to -50°F / -45.5°C

- Creates interference fit with heated aluminum heads
- Finish seat and guide work faster than ever
- Aerosol\*
- Use on tight bushings, pins, shafts, etc.
- Order No. **MFF-8** Jobber \$29.99



Buy 6 or more cans MFF-8 and save 10% off jobber



\*Hazardous Goods Fees Apply When Shipped by Air



## Valve Seat Cutting Fluid

- High silicone content reduces drag on cutters so they last longer
- Promotes smoother cuts
- May be diluted up to 9:1
- Non-aerosol spray

Size	Jobber	Order No.
1 pint spray / 473 mL	\$13.99	SCF-2
1 gallon / 3.79 L	29.99	SCF-10

CYLINDER HEAD REBUILDING

CLEANING, ASSEMBLY & SAFETY

SHORT BLOCK REBUILDING

CRANKSHAFT/FLYWHEEL GRINDING

MISCELLANEOUS TOOLS & SUPPLIES

BRAKE & TIRE CHANGING TOOLS

MEASURING TOOLS

V-TWIN & METRIC HARD PARTS

# Neway Valve Seat Cutting System

CYLINDER HEAD  
REBUILDING

CLEANING,  
ASSEMBLY & SAFETY

SHORT BLOCK  
REBUILDING

CRANKSHAFT/  
FLYWHEEL GRINDING

MISCELLANEOUS  
TOOLS & SUPPLIES

BRAKE & TIRE  
CHANGING TOOLS

MEASURING  
TOOLS

V-TWIN & METRIC  
HARD PARTS

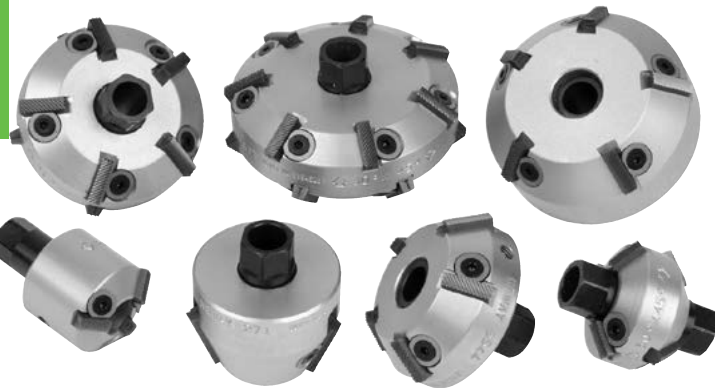

L-R: NCB-253, NCB-250,  
NCB-251, NCB-252,  
NCB-254

L-R:  
NCB-152,  
NCB-154

L-R: NCB-250LC,  
NCB-251LC

L-R: NCB-355,  
NCB-352,  
NCB-354

L-R: NCB-260,  
NCB-265, NCB-266



Description	Jobber	Order No.
<b>Small Series Cutter Bodies (Use .297" Top Pilots - page 1)</b>		
<b>Cutter Body</b>	<b>Blade</b>	<b>Qty. Replacement Blade</b>
<b>Diameter</b>	<b>Angle</b>	
0.830" / 21.1mm	32°	3 non-replaceable
0.850" / 21.6mm	45°	3 non-replaceable
0.874" / 22.2mm	60°	3 non-replaceable
0.975" / 24.8mm	31°	3 NCB-250
	31°	3 NCB-253
	45°	3 NCB-253
1.000" / 25.4mm	15°	3 NCB-253
	30°	3 NCB-250
	60°	3 NCB-252
	75°	3 NCB-254
1.125" / 28.6mm	31°/46°	3/3 NCB-253
1.312" / 33.3mm	31°/46°	3/3 NCB-251
	15°/60°	3/3 NCB-251, -254
<b>Replacement Blades</b>	<b>Angle</b>	<b>Blade Lgth.</b>
Sold Individually	15-46°	5/16" / 7.9mm
		3/8" / 9.53mm
		1/2" / 12.7mm
	60-75°	1/2" / 12.7mm
		3/4" / 19.05mm
<b>Non-Serrated Correction Blades</b>	60-75°	1/2" / 12.7mm
<b>Hard Seat Blades</b>	15-46°	3/8" / 9.53mm
		1/2" / 12.7mm
<b>Radius Combustion Chamber Blades</b>		3/8" / 9.53mm
		1/2" / 12.7mm
		3/4" / 19.05mm
Flat Head Screw		2.29
Wedge for bodies over 1" / 25.4mm		2.29
Wedge for 1" / 25.4mm & smaller bodies		2.29
Tool Kit (includes brush, 2 hex keys and pilot puller)		6.79
Large Storage Case (holds 11 pieces)		29.99
EZ-Turn Wrench		74.99
1/2" T-Handle Driver		12.79
3/8" T-Handle Driver		12.79
Drive Adaptor	1/2" to 3/8" / 12.7-9.53mm	11.79

**Accurate** The Tungsten Carbide blades on these cutters never change shape like abrasives will. You get a perfectly flat, machined surface that will give you an optimal seal and heat transfer.

**Ready to use** Cutter bodies come complete with blades. Most bodies feature replaceable blades (see chart for part numbers and quantities).

**Easy** The Neway Valve Seat Cutting System is very user-friendly. You can turn the cutters by hand with a T-handle or use the EZ-Turn Wrench (NTW-EZ) for a continuous turning motion. The EZ-Turn Wrench also includes a 1/2" to 3/8" adaptor NTW-503-1 to drive all cutter bodies (adaptor also sold separately).

**How to Order** Cutters work in a range from 3/8" smaller and 1/4" larger than the listed cutter body size. Select cutter approximately the same size as your valve head diameter.

Description	Jobber	Order No.
<b>Standard Series Cutter Bodies (Use .375" Top Pilots - page 1)</b>		
<b>Cutter Body</b>	<b>Blade</b>	<b>Qty. Replacement Blade</b>
<b>Diameter</b>	<b>Angle</b>	
1.125" / 28.6mm	30°	3 NCB-250
	45°	3 NCB-250
	60°	3 NCB-252
1.250" / 31.6mm	15°/75°	3/3 NCB-250, -254
	30°	3 NCB-250
	30°/45°	6 NCB-250
	31°/46°	6 NCB-250
	45°	5 NCB-250
	60°	3 NCB-252
1.375" / 35.0mm	15°/60°	5/5 NCB-251, -254
	30°/45°	3/3 NCB-250, -251
1.500" / 38.0mm	15°/75°	3/3 NCB-251, -254
	30°/45°	3/3 NCB-251
	30°/45°	5/5 NCB-251
	31°/46°	10 NCB-251
	60°	3 NCB-254
1.750" / 44.5mm	15°/60°	5/5 NCB-251, -254
	30°/45°	10 NCB-251
	31°/46°	10 NCB-251
	55°	5 NCB-251
	60°	3 NCB-254
	75°	3 NCB-254
2.000" / 50.8mm	31°/46°	10 NCB-251
	15°/60°	5/5 NCB-251, -254
	30°/45°	5/5 NCB-251
	50°	5 NCB-251
	60°	5 NCB-254
2.25" / 57.0mm	55°	5 NCB-251
	15°/60°	5/5 NCB-251, -254
2.50" / 63.5mm	30°/45°	7/7 NCB-251
	50°	7 NCB-251
	55°	7 NCB-251
	70°	7 NCB-254

Goodson can now make almost any Newway kit!  
Call or visit [goodson.com](http://goodson.com) for more information



## Neway Easy Turn Wrench

- Turn Newway cutters continuously
- Produces a smooth seat quickly and easily
- Improves control of material removal
- Spring loaded for improved control
- Includes drive adaptor to convert 1/2" to 3/8"

Description	Jobber	Order No.
Easy Turn Wrench	\$74.99	NTW-EZ
Drive Adaptor	11.79	NTW-503-1



## Neway T-Handle Drivers

- Use to turn Newway cutters
- Produces a smooth seat quickly and easily
- Two sizes to fit small series cutter bodies and standard series cutter bodies
- 1/2" to 3/8" adaptor available

Description	Jobber	Order No.
3/8" Hex for Small Series Bodies	\$12.79	NTW-513
1/2" Hex for Standard Series Bodies	12.79	NTW-505
1/2" to 3/8" Adaptor	11.79	NTW-503-1

DCD-375/DCD-385

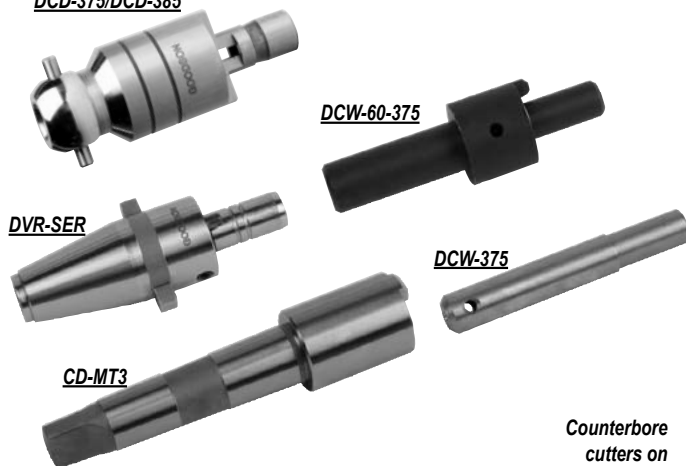

Counterbore cutters on page 14

## Counterbore Cutter Drive Adaptors

Cutter Drivers	Jobber	Order No.
#3 MT Driver	\$329.99	CD-MT3
Fits .750" Bridgeport Collet		
3/8" arbor, .375" pilot	\$120.29	DCW-60-375
3/8" arbor, .385" pilot	120.29	DCW-60-385
Ball Head Driver .375" pilot, 3/8" arbor	242.79	DCD-375
Ball Head Driver .385" pilot, 3/8" arbor	242.79	DCD-385
3/8" Driver for Serdi & Rottler SG-9A, SG-9M	339.99	DVR-SER
3/8" Driver for Serdi & Rottler SG-9A, SG-9M	299.99	DVR-SER-58

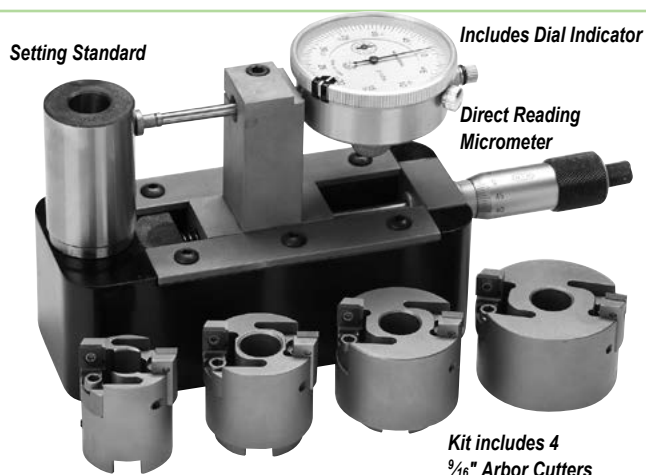

## Customize Counterbore Cutters with the GOODSON Adjustable Counterbore Cutter Kit

- Cutter assemblies feature positive stop adjusting screws to prevent cutters from changing dimensions when in use
- Direct reading micrometer and dial indicator for fast, accurate set-up • 8 cutter assemblies to choose from, covering a range from 1.25" to 3.00" diameter
- Kit substitutions are available, call to inquire
- Heavy duty billet steel construction

Complete Kit	Jobber	Order No.	Incl.
3/8" / 14.3mm Arbor	\$1799.99	DWA-300	▼
<b>Cutter Assemblies (in/mm)</b>			
3/8" Arbor	1.250"-1.375" / 31.8-34.9	\$419.99	DWA-250 x
	1.375"-1.500" / 34.9-38.1	419.99	DWA-375 x
	1.500"-1.750" / 38.1-44.5	419.99	DWA-302 x
	1.750"-2.000" / 44.5-50.8	419.99	DWA-303 x
	2.000"-2.250" / 50.8-57.2	419.99	DWA-304
	2.250"-2.500" / 57.2-63.5	419.99	DWA-305
	2.500"-2.750" / 63.5-69.9	419.99	DWA-306
	2.750"-3.000" / 69.9-76.2	419.99	DWA-307
Cutting Insert	36.49	DKB-7	x
Set Screw	13.29	DKS-7	x
Wrench	9.99	FT-WRENCH	x

To use the Counterbore Cutter Kit with Kwik-Way & Peterson Machines you will need to adapt the 3/8" cutter to fit the 3/8" drive. Use a DCW wear sleeve from the charts below.

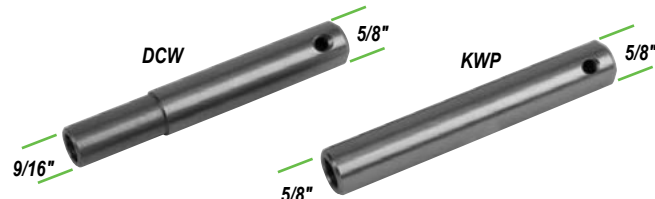

## Wear Sleeves for Counter Bore Cutters

- Wear sleeves fit CD-MT3 Driver at left

Wear Sleeves		Wear Sleeves	
For 3/8" (14.27mm) arbor DCW & DWI style seat cutters		For 3/8" / 15.87mm arbor KWP & KPI style seat cutters	
Pilot Top Size	Order No.	Pilot Top Size	Order No.
.375" (9.53mm)	DCW-375	.375" (9.53mm)	KWP-375
.385" (9.78mm)	DCW-385	.385" (9.78mm)	KWP-385
.437" (11.10mm)	DCW-437	.437" (11.10mm)	KWP-437
Jobber	\$78.79	Jobber	\$71.99

... another satisfied customer

"We have been doing business with Goodson for over 10 years. They have outstanding customer service and a great selection of specialty tooling and parts for Harleys."

- Bob LaGuardia, Diamond Bar Choppers, Diamond Bar CA, Goodson customer since 2000

CYLINDER HEAD REBUILDING

CLEANING, ASSEMBLY & SAFETY

SHORT BLOCK REBUILDING

CRANKSHAFT/ FLYWHEEL GRINDING

MISCELLANEOUS TOOLS & SUPPLIES

BRAKE & TIRE CHANGING TOOLS

MEASURING TOOLS

V-TWIN & METRIC HARD PARTS



## Indexable Counterbore Cutters

These indexable counterbore cutters eliminate down time from having brazed cutters reset or sharpened. You can service them right in your own shop! Each cutter body includes 2 carbide cutter tips with 4 cutting edges. When one edge wears, simply rotate the tip to a new cutting edge. You'll also get insert screws and a wrench with every cutter body.



### DWI-SERIES

- Fits DCM Tech, Sunnen, and Winona Van Norman
- 9/16" / 14.3mm arbor



### KPI-SERIES

- Fits Kansas Instruments, Kwik-Way and Peterson
- 5/8" / 15.9mm arbor

		DWI-Series		KPI-Series	
		DCM Tech, WVN		K.I., KW, Peterson	
		(%1/16" arbor)		(%1/8" arbor)	
Size	mm	Jobber	Order No.	Jobber	Order No.
1.062"	26.97	\$219.99	DWI-1062	—	—
1.125"	28.57	219.99	DWI-1125	—	—
1.187"	30.15	219.99	DWI-1187	—	—
1.250"	31.75	219.99	DWI-1250	\$219.99	KPI-1250
1.312"	33.32	219.99	DWI-1312	219.99	KPI-1312
1.375"	34.93	219.99	DWI-1375	219.99	KPI-1375
1.437"	36.50	219.99	DWI-1437	219.99	KPI-1437
1/4" Replacement Cutting Insert for Cutters above				27.99	SCI-250-B
Replacement Screw for SCI-250-B				4.99	SCS-T7
Allen Wrench for SCS-T7				7.99	SCW-T7

		DWI-Series		KPI-Series	
		DCM Tech, WVN		K.I., KW, Peterson	
		(%1/16" arbor)		(%1/8" arbor)	
Size	mm	Jobber	Order No.	Jobber	Order No.
1.500"	38.10	\$219.99	DWI-1500	\$219.99	KPI-1500
1.562"	39.67	219.99	DWI-1562	219.99	KPI-1562
1.625"	41.28	219.99	DWI-1625	219.99	KPI-1625
1.687"	42.85	219.99	DWI-1687	219.99	KPI-1687
1.750"	42.85	219.99	DWI-1750	219.99	KPI-1750
1.812"	44.45	219.99	DWI-1812	219.99	KPI-1812
1.875"	47.63	219.99	DWI-1875	219.99	KPI-1875
1.937"	49.20	219.99	DWI-1937	219.99	KPI-1937
2.000"	50.80	219.99	DWI-2000	219.99	KPI-2000
2.062"	52.37	219.99	DWI-2062	219.99	KPI-2062
2.125"	53.98	219.99	DWI-2125	219.99	KPI-2125
3/8" Replacement Cutting Insert for Cutters above				44.99	SCI-375-B
Replacement Screw for SCI-375-B				1.49	SCS-T15
Torx Wrench for SCS-T15				4.99	SCW-T15



## Minnesota Fast Freeze

- Creates interference fit with heated aluminum heads
- Finish seat and guide work faster than ever
- Aerosol\* • Use on tight bushings, pins, shafts, etc.
- Order No. MFF-8 Jobber \$29.99
- \* Hazardous Goods Fees Apply When Shipped Air

## Nickel-Chrome Valve Seats For a Variety Of Applications

OD	ID	Depth	Order No.	OD	ID	Depth	Order No.
1.250"	0.812"	1/4"	VS-1250	1.625"	1.375"	7/32"	VS-1625A
1.312"	1.000"	1/4"	VS-1312	1.687"	1.375"	1/4"	VS-1687
1.375"	1.062"	1/4"	VS-1375	1.750"	1.500"	1/4"	VS-1750
1.437"	1.125"	1/4"	VS-1437	1.812"	1.500"	1/4"	VS-1812
1.500"	1.187"	1/4"	VS-1500	1.875"	1.562"	1/4"	VS-1875
1.562"	1.250"	1/4"	VS-1562	1.937"	1.625"	1/4"	VS-1937
1.562"	1.312"	7/32"	VS-1562A	2.000"	1.625"	1/4"	VS-2000
1.625"	1.312"	1/4"	VS-1625				Jobber \$7.49

Buy 12 or more, save 10% off jobber



## Valve Seat Drivers For Fast Seat Installation

- Pneumatic Drivers install seats faster, easier and without galling
- Driver Head ID is .75" / 19.05mm

Description	Jobber	Order No.
<b>Manual Drivers</b>		
.375" / 9.53mm and .385" / 9.78mm ID	\$29.99	VSD-202-G
<b>Driver Heads</b>		
1.000" thru 1.125" Seats / 25.4 - 28.6mm	\$39.99	VSD-203-G
1.250" thru 1.375" Seats / 31.8 - 34.9mm	39.99	VSD-204-G
1.500" thru 1.625" Seats / 38.1 - 41.3mm	39.99	VSD-205-G
1.750" thru 1.875" Seats / 44.5 - 47.6mm	39.99	VSD-206-G
2.000" thru 2.125" Seats / 50.8 - 54.0mm	39.99	VSD-207-G
1.750" thru 2.000" Seats / 44.5 - 50.8mm	29.99	VSD-HD
<b>Pneumatic Drivers</b>		
.375" / 9.53mm and .385" / 9.78mm ID	\$29.99	PSD-385
.437" / 11.10mm ID	29.99	PSD-437



## Valve Seat Removers – A Low-Cost Way to Pull Valve Seat Inserts

- Use to pry out valve seat inserts or stubborn grease seals • Three angles available
- Not recommended for use on aluminum heads
- Set includes one of each angle

Description	Jobber	Order No.
3-Pc. Set	\$129.99	VSP-SET
90°	47.99	VSP-90
100°	47.99	VSP-100
120°	47.99	VSP-120

See page 5 for valve seat removal tools that fit 3-D Fast Cut

# Valve Lapping Tools & Supplies

## Petroleum Based Lapping Compound

- Silicone-carbide, grease-based compound
- Precise mating between valves and seats for fast cutting



Grit	Size	Jobber	Order No.
400	2 oz. / 56.7g	\$11.99	VLC-2-400
600	2 oz. / 56.7g	11.99	VLC-2-600
800	2 oz. / 56.7g	11.99	VLC-2-800
1200	2 oz. / 56.7g	17.99	VLC-2-1200
120, 280	2 oz. / 56.7g ea.	27.79	VLC-4
120	1 lb. / 453.6g	54.99	VLC-120
180	1 lb. / 453.6g	54.99	VLC-180
280	1 lb. / 453.6g	54.99	VLC-280

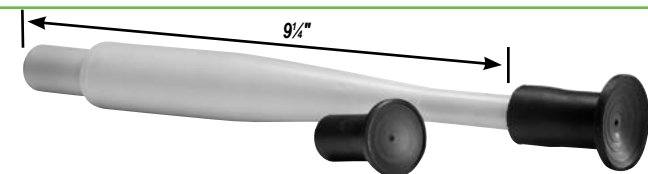

## Vacuum Style Lapping Stick

- Press the spring-loaded vacuum pump for a firm hold – stays on until you release the vacuum
- Includes 3 cup sizes (also sold separately)

Description	Cup ID	Jobber	Order No.
Vacuum Lapping Stick 9 1/2" Long		\$32.99	VLV-50
Replacement Cups	19.1mm / 0.750" dia.	.415"	7.99 VLV-3/4
	25.4mm / 1.000" dia.	.415"	7.99 VLV-1
	31.8mm / 1.250" dia.	.415"	7.99 VLV-1 1/4



## Traditional Valve Lapping Sticks

- Oil resistant polyethylene handles
- Locking tabs eliminate cup slippage

Description	Cup ID	Jobber	Order No.
Small Lapping Stick 8" Long		\$7.99	VLS-15
Replacement Cups	15.9mm / 0.625" dia.	.156"	5.99 VLS-5/8
	20.6mm / 0.813" dia.	.230"	5.99 VLS-13/16
Large Lapping Stick 8" Long		7.99	VLS-30
Replacement Cups	28.6mm / 1.125" dia.	.380"	5.99 VLS-1 1/8
	34.9mm / 1.375" dia.	.380"	5.99 VLS-1 3/8

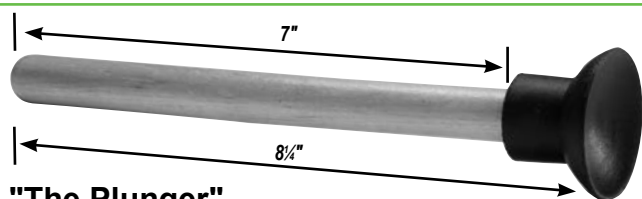

## "The Plunger" Hand Valve Lapping Stick

- Large diameter for sure grip
- For 2" and larger valves

Description	Cup ID	Jobber	Order No.
Hand Valve Lapping Stick 8 1/2" Long		\$7.99	VLS-75
Replacement Cup	44.5mm / 1.750" dia.	.313"	4.99 VLS-1 3/4

## Air Powered Valve Lapping Tool

- Operates on 90psi
- Includes air tool and 3 replacement cups • Air actuated ... no electricity needed • Cups also sold separately



Description	Cup ID	Jobber	Order No.
Air Powered Valve Lapping Tool		\$399.99	AVLP-300
Replacement Cups	21mm / 0.827" dia.	.230"	8.99 AVLP-301
	33mm / 1.299" dia.	.380"	8.99 AVLP-302
	38mm / 1.496" dia.	.380"	8.99 AVLP-303

## Mechanical Valve Lapping Tool

- Auto oscillation with a simple crank
- Includes blade drive for slotted valves

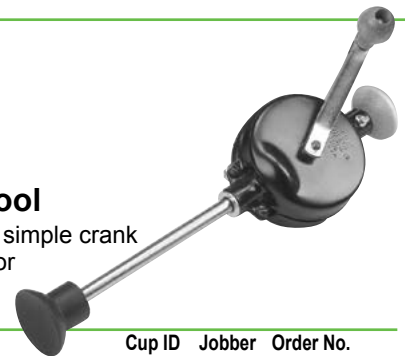

Description	Cup ID	Jobber	Order No.
Mechanical Valve Lapping Tool		\$24.99	VL-EB
Replacement Cups	33.3mm / 1.313" dia.	.297"	3.99 VLS-1 5/16
	44.5mm / 1.750" dia.	.313"	4.99 VLS-1 3/4

## Powered Lapping Tool

- Change rotary action into an effective oscillating motion • Drive with a power drill
- Makes lapping faster and easier
- Includes 2 cup sizes



Description	Cup ID	Jobber	Order No.
Complete Tool		\$169.99	VLP-100
Replacement Cups	22.2mm / 0.875" dia.	.460"	9.99 VLP-10
	25.4mm / 1.000" dia.	.460"	9.99 VLP-20



Buy 6 or more cans SBF-16 and save 10%

## Check valve to seat contact with any of these layout fluids



Description	Color	Jobber	Order No.
Layout Fluid Markers	Blue	\$9.99	VBF-2
2 oz. / 59 mL	Red	9.99	VRF-2
Layout Fluid 4oz. / 118mL	Blue	9.99	VBF-4
(Includes brush)	Red	9.99	VRF-4
Prussian Blue Machining Paste 3/4 oz. / 22mL		8.49	PB-75
Spray Bluing Fluid (Aerosol)*	Blue	9.99	SBF-16*

\*Hazardous Goods Fees Apply When Shipped by Air

CYLINDER HEAD REBUILDING  
CLEANING, ASSEMBLY & SAFETY  
SHORT BLOCK REBUILDING  
CRANKSHAFT/FLYWHEEL GRINDING  
MISCELLANEOUS TOOLS & SUPPLIES  
BRAKE & TIRE CHANGING TOOLS  
MEASURING TOOLS  
V-TWIN & METRIC HARD PARTS



## Goodson seat wheels are built to grind accurately & outlast the competition

- Brass bushings resist galling or seizing to the holder
- Heat-cured, permanent epoxy bonding prevents loose bushings
- Bushings are set deep to expose the most abrasive for long life
- Each wheel is pre-trued and checked to assure accurate, vibration-free grinding

**tech tips**  
from the techxperts™

### Ordering is easy!

- 1 - Find the diameter (valve head diameter + 1/16" to 1/8").
- 2 - Find the angle you need (you can modify angles with our Valve Seat Stone Dresser, page 20).
- 3 - Select the abrasive to match your job.

**KW**

Fits Kwik-Way 13/16"x13 thread

**GP**

**General Purpose**

Removes material from cast-iron seats or inserts. Ideal for antiques.

**S**

**Stellite**

Specially formulated to grind Stellite and other types of hardened seat inserts, ie. Diesel & Industrial.

**NC**

**Nickel Chrome**

For aluminum heads with chrom-alloy seat inserts. Won't load up or groove. Speckled.

## 6 ABRASIVE FORMULAS TO CHOOSE FROM

**CB**

**Cool Blue**

Superior general purpose stone for high performance Beryllium seats. Cuts faster. For tractors and trucks with diesel engines.

**F**

**Finish**

Gives an ideal final finish with minimal stock removal.

**R**

**Ruby**

The original Black & Decker composition, general purpose stone.

Custom angles and sizes are available in house. Call for more information.

Colors may vary due to manufacturing processes

Size	General Purpose (GP)			Cool Blue (CB)		Finishing (F)		Stellite (S)	
Inch mm Jobber	00°	30°	45°	00°	45°	30°	45°	00°	45°
1 1/4" 32 \$13.99	KW-1000-GP	KW-1030-GP	KW-1045-GP	KW-1000-CB	KW-1045-CB	—	KW-1045-F	KW-1000-S	KW-1045-S
1 3/16" 33 13.99	KW-1000A-GP	—	KW-1045A-GP	KW-1000A-CB	KW-1045A-CB	—	—	—	—
1 3/8" 35 13.99	KW-1100-GP	KW-1130-GP	KW-1145-GP	KW-1100-CB	KW-1145-CB	KW-1130-F	KW-1145-F	KW-1100-S	KW-1145-S
1 7/16" 36 13.99	KW-1100A-GP	—	KW-1145A-GP	KW-1100A-CB	KW-1145A-CB	—	KW-1145A-F	KW-1100A-S	KW-1145A-S
1 1/2" 38 13.99	KW-1200-GP	KW-1230-GP	KW-1245-GP	KW-1200-CB	KW-1245-CB	KW-1230-F	KW-1245-F	KW-1200-S	KW-1245-S
1 9/16" 39 13.99	KW-1200A-GP	—	KW-1245A-GP	—	KW-1245A-CB	—	KW-1245A-F	KW-1200A-S	KW-1245A-S
1 5/8" 41 13.99	KW-1300-GP	KW-1330-GP	KW-1345-GP	KW-1300-CB	KW-1345-CB	KW-1330-F	KW-1345-F	KW-1300-S	KW-1345-S
1 11/16" 43 13.99	KW-1300A-GP	—	KW-1345A-GP	KW-1300A-CB	KW-1345A-CB	—	KW-1345A-F	KW-1300A-S	KW-1345A-S
1 3/4" 44 13.99	KW-1400-GP	KW-1430-GP	KW-1445-GP	KW-1400-CB	KW-1445-CB	KW-1430-F	KW-1445-F	KW-1400-S	KW-1445-S
1 7/8" 47 13.99	KW-1500-GP	KW-1530-GP	KW-1545-GP	KW-1500-CB	KW-1545-CB	KW-1530-F	KW-1545-F	KW-1500-S	KW-1545-S
2" 51 13.99	KW-1600-GP	KW-1630-GP	KW-1645-GP	KW-1600-CB	KW-1645-CB	KW-1630-F	KW-1645-F	KW-1600-S	KW-1645-S
2 1/8" 54 13.99	KW-1700-GP	KW-1730-GP	KW-1745-GP	KW-1700-CB	KW-1745-CB	KW-1730-F	KW-1745-F	KW-1700-S	KW-1745-S
2 1/4" 57 13.99	KW-1800-GP	KW-1830-GP	KW-1845-GP	KW-1800-CB	KW-1845-CB	—	KW-1845-F	KW-1800-S	KW-1845-S
2 3/8" 60 13.99	KW-1900-GP	KW-1930-GP	KW-1945-GP	KW-1900-CB	KW-1945-CB	—	—	—	—
2 1/2" 63 13.99	KW-2000-GP	KW-2030-GP	KW-2045-GP	KW-2000-CB	KW-2045-CB	—	—	—	—
2 5/8" 67 15.99	KW-2100-GP	KW-2130-GP	KW-2145-GP	KW-2100-CB	KW-2145-CB	—	—	—	—
2 3/4" 70 16.99	KW-2200-GP	KW-2230-GP	KW-2245-GP	KW-2200-CB	KW-2245-CB	—	—	—	—
2 7/8" 73 16.99	KW-2200A-GP	KW-2230A-GP	KW-2245A-GP	KW-2200A-CB	KW-2245A-CB	—	—	—	—

Size	Nickel Chrome (NC)		Ruby (R)		
Inch mm Jobber	00°	45°	00°	45°	
1" 25 \$16.99	KW-700-NC	KW-745-NC	\$17.99	KW-700-R	KW-745-R
1 1/16" 27 16.99	KW-800-NC	KW-845-NC	17.99	KW-800-R	KW-845-R
1 1/8" 28 16.99	KW-900-NC	KW-945-NC	17.99	KW-900-R	KW-945-R
1 1/4" 32 14.99	KW-1000-NC	KW-1045-NC	14.99	KW-1000-R	KW-1045-R
1 3/8" 35 14.99	KW-1100-NC	KW-1145-NC	14.99	KW-1100-R	KW-1145-R
1 7/16" 36 14.99	KW-1100A-NC	KW-1145A-NC	—	—	—
1 1/2" 38 14.99	KW-1200-NC	KW-1245-NC	14.99	KW-1200-R	KW-1245-R
1 9/16" 39 14.99	KW-1200A-NC	KW-1245A-NC	—	—	—
1 5/8" 41 14.99	KW-1300-NC	KW-1345-NC	14.99	KW-1300-R	KW-1345-R
1 11/16" 43 14.99	KW-1300A-NC	KW-1345A-NC	—	—	—
1 3/4" 44 14.99	KW-1400-NC	KW-1445-NC	14.99	KW-1400-R	KW-1445-R
1 7/8" 47 14.99	KW-1500-NC	KW-1545-NC	14.99	KW-1500-R	KW-1545-R
2" 51 14.99	KW-1600-NC	KW-1645-NC	14.99	KW-1600-R	KW-1645-R
2 1/8" 54 15.99	KW-1700-NC	KW-1745-NC	—	—	—
2 1/4" 57 15.99	KW-1800-NC	KW-1845-NC	—	—	—
2 3/8" 60 15.99	KW-1900-NC	KW-1945-NC	—	—	—
2 1/2" 63 15.99	KW-2000-NC	KW-2045-NC	—	—	—
2 5/8" 67 16.99	KW-2100-NC	KW-2145-NC	—	—	—
2 3/4" 70 16.99	KW-2200-NC	KW-2245-NC	—	—	—
2 7/8" 73 16.99	KW-2200A-NC	KW-2245A-NC	—	—	—

**45° Large Diameter Valve Seat Wheels**

- Fits Kwik-Way 13/16"x13 thread

	General Purpose		Nickel-Chrome	Cool Blue
Inch mm	Order No.	Order No.	Order No.	Order No.
3" 76.2	KWL-2345-GP	KWL-2345-NC	KWL-2345-CB	
3 1/4" 82.5	KWL-2445-GP	KWL-2445-NC	KWL-2445-CB	
3 1/2" 88.9	KWL-2545-GP	KWL-2545-NC	KWL-2545-CB	
3 3/4" 92.3	KWL-2645-GP	KWL-2645-NC	KWL-2645-CB	
4" 101.6	KWL-2745-GP	KWL-2745-NC	KWL-2745-CB	
Jobber	\$24.99	\$24.99	\$24.99	





# Save 10% on 10!

Order 10 or more Valve Seat Wheels (any combination, pages 16-18) and we'll give you 10% off jobber



# SX

Fits Sioux™, KO Lee, US, Thor, Skil, Winona 11/16"x16 thread

Colors may vary due to manufacturing processes

Size		General Purpose (GP)				Cool Blue (CB)		Ruby				
Inch	mm	Jobber	00°	30°	45°	60°	00°	45°	Jobber	00°	45°	
7/8"	22	—	—	—	—	—	—	—	\$22.99	SX-500-R	SX-545-R	
15/16"	24	—	—	—	—	—	—	—	22.99	SX-600-R	SX-645-R	
1"	25	—	—	—	—	—	—	—	22.99	SX-700-R	SX-745-R	
1 1/16"	27	—	—	—	—	—	—	—	22.99	SX-800-R	SX-845-R	
1 1/8"	28	\$19.99	SX-900-GP	SX-930-GP	SX-945-GP	—	—	—	22.99	SX-900-R	SX-945-R	
1 3/16"	30	19.99	SX-900A-GP	—	SX-945A-GP	—	—	—	—	—	—	
1 1/4"	32	13.49	SX-1000-GP	SX-1030-GP	SX-1045-GP	SX-1060-GP	\$13.49	SX-1000-CB	SX-1045-CB	13.49	SX-1000-R	SX-1045-R
1 5/16"	33	13.49	SX-1000A-GP	—	SX-1045A-GP	—	13.49	SX-1000A-CB	SX-1045A-CB	—	—	—
1 3/8"	35	13.49	SX-1100-GP	SX-1130-GP	SX-1145-GP	SX-1160-GP	13.49	SX-1100-CB	SX-1145-CB	13.49	SX-1100-R	SX-1145-R
1 7/16"	36	13.49	SX-1100A-GP	—	SX-1145A-GP	—	13.49	SX-1100A-CB	SX-1145A-CB	—	—	—
1 1/2"	38	13.49	SX-1200-GP	SX-1230-GP	SX-1245-GP	SX-1260-GP	13.49	SX-1200-CB	SX-1245-CB	13.49	SX-1200-R	SX-1245-R
1 9/16"	39	13.49	SX-1200A-GP	—	SX-1245A-GP	—	13.49	SX-1200A-CB	SX-1245A-CB	—	—	—
1 5/8"	41	13.49	SX-1300-GP	SX-1330-GP	SX-1345-GP	SX-1360-GP	13.49	SX-1300-CB	SX-1345-CB	13.49	SX-1300-R	SX-1345-R
1 11/16"	43	13.49	SX-1300A-GP	—	SX-1345A-GP	—	13.49	SX-1300A-CB	SX-1345A-CB	—	—	—
1 3/4"	44	13.49	SX-1400-GP	SX-1430-GP	SX-1445-GP	SX-1460-GP	13.49	SX-1400-CB	SX-1445-CB	13.49	SX-1400-R	SX-1445-R
1 7/8"	47	13.49	SX-1500-GP	SX-1530-GP	SX-1545-GP	SX-1560-GP	13.49	SX-1500-CB	SX-1545-CB	13.49	SX-1500-R	SX-1545-R
2"	51	13.49	SX-1600-GP	SX-1630-GP	SX-1645-GP	SX-1660-GP	13.49	SX-1600-CB	SX-1645-CB	13.49	SX-1600-R	SX-1645-R
2 1/8"	54	13.49	SX-1700-GP	SX-1730-GP	SX-1745-GP	—	13.49	SX-1700-CB	SX-1745-CB	13.49	SX-1700-R	SX-1745-R
2 1/4"	57	13.49	SX-1800-GP	SX-1830-GP	SX-1845-GP	SX-1860-GP	13.49	SX-1800-CB	SX-1845-CB	13.49	SX-1800-R	SX-1845-R
2 3/8"	60	13.49	SX-1900-GP	SX-1930-GP	SX-1945-GP	SX-1960-GP	13.49	SX-1900-CB	SX-1945-CB	13.49	SX-1900-R	SX-1945-R
2 1/2"	63	13.49	SX-2000-GP	SX-2030-GP	SX-2045-GP	—	13.49	SX-2000-CB	SX-2045-CB	13.49	SX-2000-R	SX-2045-R
2 5/8"	66	13.49	SX-2100-GP	SX-2130-GP	SX-2145-GP	—	13.49	SX-2100-CB	SX-2145-CB	—	—	—
2 3/4"	70	15.99	SX-2200-GP	SX-2230-GP	SX-2245-GP	—	15.99	SX-2200-CB	SX-2245-CB	—	—	—
2 7/8"	73	15.99	SX-2200A-GP	SX-2230A-GP	SX-2245A-GP	—	15.99	SX-2200A-CB	SX-2245A-CB	—	—	—

Size		Stellite (S)			Finishing (F)			Nickel Chrome					
Inch	mm	Jobber	00°	30°	45°	Jobber	00°	30°	45°	Jobber	00°	30°	45°
1/2"	12.7	—	—	—	—	—	—	—	—	\$22.99	SX-200-NC	—	—
3/8"	14.3	—	—	—	—	—	—	—	—	22.99	SX-200A-NC	—	—
5/8"	15.9	—	—	—	—	—	—	—	—	22.99	SX-300-NC	—	—
1 1/16"	17.4	—	—	—	—	—	—	—	—	22.99	SX-300A-NC	—	—
3/4"	19.1	—	—	—	—	—	—	—	—	22.99	SX-400-NC	—	—
13/16"	20.6	—	—	—	—	—	—	—	—	22.99	SX-400A-NC	—	—
7/8"	22	—	—	—	—	\$22.99	SX-500-F	—	SX-545-F	22.99	SX-500-NC	—	SX-545-NC
1 5/16"	24	—	—	—	—	22.99	SX-600-F	—	SX-645-F	22.99	SX-600-NC	—	SX-645-NC
1"	25	—	—	—	—	22.99	SX-700-F	—	SX-745-F	22.99	SX-700-NC	—	SX-745-NC
1 1/16"	27	—	—	—	—	22.99	SX-800-F	—	SX-845-F	22.99	SX-800-NC	—	SX-845-NC
1 1/8"	28	\$19.99	SX-900-S	SX-930-S	SX-945-S	19.99	SX-900-F	SX-930-F	SX-945-F	19.99	SX-900-NC	SX-930-NC	SX-945-NC
1 3/16"	30	19.99	SX-900A-S	—	SX-945A-S	19.99	SX-900A-F	—	SX-945A-F	19.99	SX-900A-NC	—	SX-945A-NC
1 1/4"	32	12.99	SX-1000-S	SX-1030-S	SX-1045-S	13.49	SX-1000-F	SX-1030-F	SX-1045-F	13.99	SX-1000-NC	SX-1030-NC	SX-1045-NC
1 5/16"	33	12.99	SX-1000A-S	—	SX-1045A-S	13.49	SX-1000A-F	—	SX-1045A-F	13.99	SX-1000A-NC	—	SX-1045A-NC
1 3/8"	35	12.99	SX-1100-S	SX-1130-S	SX-1145-S	12.99	SX-1100-F	SX-1130-F	SX-1145-F	13.99	SX-1100-NC	SX-1130-NC	SX-1145-NC
1 7/16"	36	12.99	SX-1100A-S	—	SX-1145A-S	12.99	SX-1100A-F	—	SX-1145A-F	13.99	SX-1100A-NC	—	SX-1145A-NC
1 1/2"	38	12.99	SX-1200-S	SX-1230-S	SX-1245-S	11.49	SX-1200-F	SX-1230-F	SX-1245-F	13.99	SX-1200-NC	SX-1230-NC	SX-1245-NC
1 9/16"	39	12.99	SX-1200A-S	—	SX-1245A-S	11.49	SX-1200A-F	—	SX-1245A-F	13.99	SX-1200A-NC	—	SX-1245A-NC
1 5/8"	41	12.99	SX-1300-S	SX-1330-S	SX-1345-S	11.49	SX-1300-F	SX-1330-F	SX-1345-F	13.99	SX-1300-NC	SX-1330-NC	SX-1345-NC
1 11/16"	43	12.99	SX-1300A-S	—	SX-1345A-S	11.49	SX-1300A-F	—	SX-1345A-F	13.99	SX-1300A-NC	—	SX-1345A-NC
1 3/4"	44	12.99	SX-1400-S	SX-1430-S	SX-1445-S	11.49	SX-1400-F	SX-1430-F	SX-1445-F	13.99	SX-1400-NC	SX-1430-NC	SX-1445-NC
1 7/8"	47	12.99	SX-1500-S	SX-1530-S	SX-1545-S	11.49	SX-1500-F	SX-1530-F	SX-1545-F	13.99	SX-1500-NC	SX-1530-NC	SX-1545-NC
2"	51	12.99	SX-1600-S	SX-1630-S	SX-1645-S	11.49	SX-1600-F	SX-1630-F	SX-1645-F	13.99	SX-1600-NC	SX-1630-NC	SX-1645-NC
2 1/8"	54	12.99	SX-1700-S	SX-1730-S	SX-1745-S	11.99	SX-1700-F	SX-1730-F	SX-1745-F	13.99	SX-1700-NC	SX-1730-NC	SX-1745-NC
2 1/4"	57	12.99	SX-1800-S	SX-1830-S	SX-1845-S	11.99	SX-1800-F	SX-1830-F	SX-1845-F	13.99	SX-1800-NC	SX-1830-NC	SX-1845-NC
2 3/8"	60	12.99	SX-1900-S	SX-1930-S	SX-1945-S	14.49	SX-1900-F	SX-1930-F	SX-1945-F	13.99	SX-1900-NC	SX-1930-NC	SX-1945-NC
2 1/2"	63	12.99	SX-2000-S	SX-2030-S	SX-2045-S	14.99	SX-2000-F	SX-2030-F	SX-2045-F	13.99	SX-2000-NC	SX-2030-NC	SX-2045-NC
2 5/8"	66	—	—	—	—	—	—	—	—	15.99	SX-2100-NC	SX-2130-NC	SX-2145-NC
2 3/4"	70	—	—	—	—	—	—	—	—	15.99	SX-2200-NC	SX-2230-NC	SX-2245-NC
2 7/8"	73	—	—	—	—	—	—	—	—	15.99	SX-2200A-NC	SX-2230A-NC	SX-2245A-NC

All Valve Seat Wheels are guaranteed against manufacturing defects for 1 year from original purchase date

CYLINDER HEAD REBUILDING  
CLEANING, ASSEMBLY & SAFETY  
SHORT BLOCK REBUILDING  
CRANKSHAFT/FLYWHEEL GRINDING  
MISCELLANEOUS TOOLS & SUPPLIES  
BRAKE & TIRE CHANGING TOOLS  
MEASURING TOOLS  
V-TWIN & METRIC HARD PARTS

same day shipping

Order 10 or more Valve Seat Wheels (any combination, pages 16-18) and we'll give you 10% off jobber



**BD**

Black & Decker, Van Dorn 5/16"x16 thread

**SO**

Snap-On 5/8"x18 thread

Size		General Purpose (GP)					Stellite (S)			General Purpose (GP)			Stellite (S)
Inch	mm	Jobber	00°	30°	45°	Jobber	00°	45°	Jobber	45°	00°		
1 1/4"	32	\$12.49	BD-1000-GP	BD-1030-GP	BD-1045-GP	\$12.99	BD-1000-S	BD-1045-S	\$12.99	SO-1045-GP	SO-1000-S		
1 5/16"	33	12.49	BD-1000A-GP	BD-1045A-GP	12.99	BD-1000A-S	BD-1045A-S	12.99	SO-1045-GP	SO-1000-S			
1 3/8"	35	12.49	BD-1100-GP	BD-1130-GP	BD-1145-GP	12.99	BD-1100-S	BD-1145-S	12.99	SO-1145-GP	SO-1100-S		
1 7/16"	36	12.49	BD-1100A-GP	BD-1145A-GP	12.99	BD-1100A-S	BD-1145A-S	12.99	SO-1145-GP	SO-1100-S			
1 1/2"	38	12.49	BD-1200-GP	BD-1230-GP	BD-1245-GP	12.99	BD-1200-S	BD-1245-S	12.99	SO-1245-GP	SO-1200-S		
1 9/16"	39	12.49	BD-1200A-GP	BD-1245A-GP	12.99	BD-1200A-S	BD-1245A-S	12.99	SO-1245-GP	SO-1200-S			
1 5/8"	41	12.49	BD-1300-GP	BD-1330-GP	BD-1345-GP	12.99	BD-1300-S	BD-1345-S	12.99	SO-1345-GP	SO-1300-S		
1 11/16"	43	12.49	BD-1300A-GP	BD-1345A-GP	12.99	BD-1300A-S	BD-1345A-S	12.99	SO-1345-GP	SO-1300-S			
1 3/4"	44	12.49	BD-1400-GP	BD-1430-GP	BD-1445-GP	12.99	BD-1400-S	BD-1445-S	12.99	SO-1445-GP	SO-1400-S		
1 7/8"	47	12.49	BD-1500-GP	BD-1530-GP	BD-1545-GP	12.99	BD-1500-S	BD-1545-S	12.99	SO-1545-GP	SO-1500-S		
2"	51	12.49	BD-1600-GP	BD-1630-GP	BD-1645-GP	12.99	BD-1600-S	BD-1645-S	12.99	SO-1645-GP	SO-1600-S		
2 1/8"	54	12.49	BD-1700-GP	BD-1730-GP	BD-1745-GP	12.99	BD-1700-S	BD-1745-S	12.99	SO-1645-GP	SO-1600-S		
2 1/4"	57	12.49	BD-1800-GP	BD-1830-GP	BD-1845-GP	12.99	BD-1800-S	BD-1845-S	12.99	SO-1645-GP	SO-1600-S		
2 3/8"	60	12.49	BD-1900-GP	BD-1930-GP	BD-1945-GP	12.99	BD-1900-S	BD-1945-S	12.99	SO-1645-GP	SO-1600-S		

**Large Diameter Valve Seat Wheels**

- Specially designed bushing allows you to use stone with either angle toward workpiece
- Three abrasive formulations to choose from: General Purpose, Nickel Chrome, Cool Blue
- SXL wheels feature 30° on one face, 45° on the other



General Purpose		Double Angle		Nickel Chrome		Cool Blue	
Inch	mm	Jobber	Order No.	Jobber	Order No.	Jobber	Order No.
2 5/8"	66.7	\$23.49	SXL-2145-GP	\$24.99	KWL-2345-GP	\$23.99	SXL-2345-NC
3"	76.2	23.99	SXL-2345-GP	24.99	KWL-2445-GP	23.99	SXL-2345-CB
3 1/4"	82.5	23.99	SXL-2445-GP	24.99	KWL-2445-NC	23.99	SXL-2445-CB
3 1/2"	88.9	23.99	SXL-2545-GP	24.99	KWL-2545-GP	23.99	SXL-2545-CB
3 3/4"	92.3	23.99	SXL-2645-GP	24.99	KWL-2645-GP	23.99	SXL-2645-CB
4"	101.6	23.99	SXL-2745-GP	24.99	KWL-2745-GP	23.99	SXL-2745-CB

**tech tips**  
from the techxperts™

Regardless of which abrasive you select and the application you are working on, you can make almost any abrasive grinding wheel function differently simply by changing the speed in which you traverse the diamond across the wheel. If you dress slowly you will close off the grains and bond and make the stone act like a finishing type of abrasive and if you traverse at a rapid pace across the wheel you will make it very aggressive. A medium speed is what you'll use the most. Goodson offers six different types of abrasive, so you don't have to adjust your dressing technique each and every time you grind, but if you're in a pinch, give this a try.

Looking for more tech tips on choosing and using Valve Seat Grinding Stones, visit the Goodson Blog; search for "seat stones" or scan the code at right with your smart phone.



**Extra Large Diameter SX Valve Seat Wheels**

- Double angle: 30° on one side; 45° on the other
- Use with your OE Sioux™ 1703-5 stone holder
- 1" hole (no threads)

		General Purpose		Nickel Chrome	
Inch	mm	Jobber	Order No.	Jobber	Order No.
4"	101.6	\$39.99	SXXL-2745-GP	\$39.99	SXXL-2745-NC
4 1/4"	108.0	39.99	SXXL-2845-GP	39.99	SXXL-2845-NC
4 1/2"	114.3	39.99	SXXL-2945-GP	39.99	SXXL-2945-NC
4 3/4"	120.7	43.99	SXXL-3045-GP	43.99	SXXL-3045-NC
5"	127.0	43.99	SXXL-3145-GP	43.99	SXXL-3145-NC



CYLINDER REBUILDING  
CLEANING, ASSEMBLY & SAFETY  
SHORT BLOCK REBUILDING  
CRANKSHAFT/ FLYWHEEL GRINDING  
MISCELLANEOUS TOOLS & SUPPLIES  
BRAKE & TIRE CHANGING TOOLS  
MEASURING TOOLS  
V-TWIN & METRIC HARD PARTS

# Air & Electric Seat Grinder Motors



## Flex Drive (SGF) Heavy Duty Electric Motor Unit

- Heavy duty electric motor
- Flex Drive allows for slight operator misalignment
- 11,500 RPM
- Weighs 12 lbs. • 3/5 HP • 7.5 Amps

Description	Jobber	Order No.
110V, 50/60Hz	\$1399.99	<b>031-3000-15</b>
220V, 50/60Hz	1499.99	<b>031-3000-35</b>
Replacement Nose Assembly	679.99	<b>031-3005-17</b>

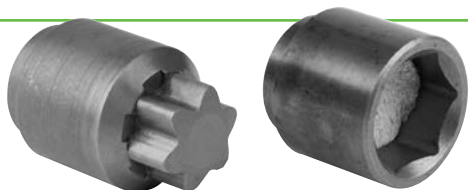

034-3112-00

031-3112-17

## Replacement Drive Assemblies

- Easy to install
- Always keep one on hand for emergencies

Description	Jobber	Order No.
Spline Drive	\$74.99	<b>034-3112-00</b>
Hex Drive with Leather Washer	74.99	<b>031-3112-17</b>
Replacement Leather Washer	3.99	<b>031-1009-41</b>



## Kwik-Way 45° Hex Drive (SGH) Electric Motor Unit

- Heavy duty electric motor
- 11,500 RPM • Weighs 9 lbs. • 3/5 HP • 7.5 amps
- Use with Hex Drive Stone Holders (page 21)

031-3112-17

Description	Jobber	Order No.
110V, 50/60Hz	\$1299.99	<b>031-3100-20</b>
220V, 50/60Hz	1399.99	<b>031-3100-27</b>
Replacement Nose Assembly	679.99	<b>031-3105-12</b>
Hex Drive Assembly with Leather Washer	74.99	<b>031-3112-17</b>



## 45° (SGK) Sioux-Style Spline Drive Electric Motor Unit

- Heavy duty electric motor • 11,500 RPM
- Weighs 9 lbs. • 3/5 HP • 7.5 amps
- Use with SX Stone Holder (page 21)

034-3112-00

Description	Jobber	Order No.
110V, 50/60Hz	\$1329.99	<b>031-3100-21</b>
220V, 50/60Hz	1499.99	<b>031-3100-28</b>
Replacement Nose Assembly	729.99	<b>034-3105-00</b>
Replacement Spline Drive Assembly	74.99	<b>034-3112-00</b>



## Sioux-Style Spline Drive 90° Angle High-Speed Air Driver

- ¼" air inlet • Max 1.0 HP
- 2½" wheel capacity
- Weighs 5½ lbs / 2.5 kg
- 10,000 RPM (governed)
- Order No. **1792AG**
- Jobber \$367.49

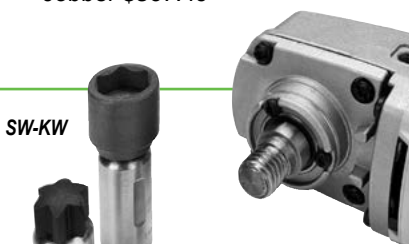

SW-KW

SW-SX

## Valve Seat Grinder Adaptors

- Turn your 4½" Angle Grinder with ½"x11 threads into a Valve Seat Grinder
- Available for Sioux, Black & Decker and Kwik-Way
- Stone holders and pilots available separately

Description	Jobber	Order No.
Spline-Drive (Sioux-Style) Adaptor	\$129.99	<b>SW-SX</b>
Hex Socket (Kwik-Way) Adaptor	129.99	<b>SW-KW</b>

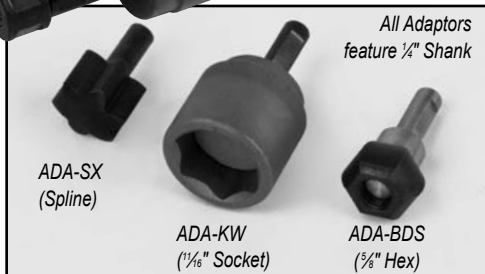

ADA-SX  
(Spline)

ADA-KW  
(1/8" Socket)

All Adaptors  
feature 1/8" Shank  
ADA-BDS  
(3/8" Hex)

## Universal 4500 RPM Air Driver and Adaptors

- Planetary gear set-up reduces speed to 4500 RPM for best finish, more control and increased torque
- Use vertically to reduce side load on stones
- Weighs just 2 lbs./0.91 kg
- Adaptors available for a variety of stone holders
- Precision clamping collet and wrenches included
- Use with bounce springs (pg. 20) for best results

Description	Jobber	Order No.
4500 RPM Air Driver	\$139.99	<b>AG-4500</b>
Hexball Driver	79.99	<b>ADA-BDS</b>
Kwik-Way Drive Adaptor	79.99	<b>ADA-KW</b>
Sioux-Style Drive Adaptor	79.99	<b>ADA-SX</b>

CYLINDER HEAD REBUILDING  
CLEANING, ASSEMBLY & SAFETY  
SHORT BLOCK  
FLYWHEEL GRINDING  
CRANKSHAFT/  
MISCELLANEOUS  
BRAKE & TIRE  
CHANGING TOOLS  
MEASURING TOOLS  
V-TWIN & METRIC HARD PARTS

... another satisfied customer

"It has been a long time since I have seen such a great vendor as these people, they are simply great. I give them an A+++ rating and hope to deal with them more."  
 - Wayne Hudson, Hillboro, Oregon (via Facebook), Goodson customer since 2014

CYLINDER HEAD REBUILDING

CLEANING, ASSEMBLY & SAFETY

SHORT BLOCK REBUILDING

CRANKSHAFT/ FLYWHEEL GRINDING

MISCELLANEOUS TOOLS & SUPPLIES

BRAKE & TIRE CHANGING TOOLS

MEASURING TOOLS

V-TWIN & METRIC HARD PARTS

**Goodson**  
EXCLUSIVE

American Made

## Universal Valve Seat Wheel Dressing Stand

- Infinitely adjustable from 0° to 90°
- Scale marked in 1° increments
- Dress stones up to 4" diameter
- Includes Premium dresser diamond
- Base has pre-drilled holes for easy mounting to your bench
- **Order dresser pilot separately from chart at right**



Stones and Holders sold separately

new design

Description	Jobber	Order No.	Incl.
Universal Dressing Stand	\$599.99	<b>SWD-UNI</b>	▼
Replacement Premium Dressing Diamond	79.99	<b>G-13P</b>	x
Dressing Stand Riser Bushings (.250" & .875" Tall)	9.99	<b>SK-9-10</b>	x

Replacement Parts			
Spring Detent	19.99	<b>SWD-UNI-DET</b>	
Arm Assembly with Spring & Plunger	239.99	<b>SWD-UNI-ARM</b>	

See pages 16-21 for valve seat stones, stone holders, air drivers, etc.

## Valve Seat Height Gauge

- Adjusts for all popular valve seat diameters • Gauge accurate to .001"
- Seat contact probe aligns on valve seat while gauge rides along the fire deck • Pilot aligns in valve guide
- Fully adjustable seat contact probe and gauge positions allow tool to fit popular seat diameters from .750" to 3.00"
- Includes Dial Indicator



Description	Fits Pilot	Jobber	Order No.
Valve Seat Height Gauge Kit	.375"	\$94.99	<b>VSHG-375</b>
Replacement Dial Indicator		27.99	<b>EDI-1</b>

## Seat Stone Removal Tool

Once in a while a valve seat stone will be so tight on the stone holder that it's almost impossible to get off. That's why we came up with this tool. Simply fasten it to your bench with screws or bolts (not included) or clamp it in a vise, set the holder onto the fixture and twist the stone off easily.

Description	Jobber	Order No.
Sioux-Style	\$24.99	<b>SX-SRT</b>
Kwik-Way Style	24.99	<b>KW-SRT</b>



American Made

## Heavy Duty Valve Seat Wheel Dresser

- Ball bearing mounted diamond carrier
- Adjustable in 1° increments from 0° to 90°
- Includes diamond
- **Order dressing pilot separately from list below**
- Designed for maximum accuracy



Description	Jobber	Order No.
Heavy Duty Dresser	\$1129.99	<b>031-1900-02</b>
Replacement Diamond Dresser	37.79	<b>G-18</b>

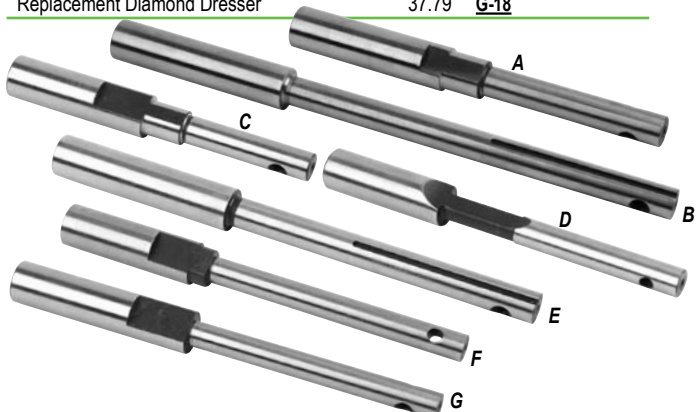

Dresser Pilots (select based on stone holder type)			
Fits Stone Holder Type	OAL	Jobber	Order No.
A .437" Hex Stone Holder	5 7/8"	\$149.99	<b>031-1102-89</b>
B .437" Hex Stone Holder	8 1/2"	149.99	<b>031-0202-71</b>
C .406" Hex Stone Holder	4 3/8"	149.99	<b>031-1102-03</b>
D .406" Hex Stone Holder	5 1/2"	149.99	<b>031-1102-38</b>
E .437" Hex or Flex Stone Holder	7 1/4"	149.99	<b>031-0202-80</b>
F .385" Top Stone Holder	6"	149.99	<b>031-0202-55</b>
G .375" Top Stone Holder	6 3/8"	149.99	<b>031-0202-47</b>

## tech tips

from the techxperts™  
 Goodson recommends using Bounce Springs with your Valve Seat Stones to prevent damage to the stone and the seat. This is especially important with the very small stones.

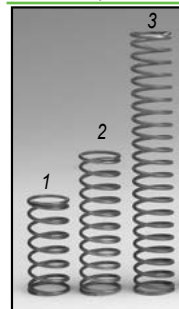
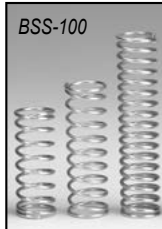

## Small Diameter Bounce Springs

Length / mm	Jobber	Order No.
1.10" / 27.9	\$7.99	<b>BS-1</b>
1.67" / 42.4	7.99	<b>BS-2</b>
3.00" / 76.2	7.99	<b>BS-3</b>

## Standard Bounce Spring Set

- Includes 1 each of 3 lengths: 1" / 24.5mm, 1 1/2" / 38.1mm and 2" / 50.8mm
- ID = .450" / 11.4mm
- OD = .570" / 14.5mm
- Order No. **BSS-100**  
 Jobber \$16.99

# Seat Stone Holders, Adaptors & More

## Valve Seat Stone Holders & Accessories

- Ball-bearing stone holders • Ideal replacements for worn holders • Save time by having several holders set up with commonly used sizes, compositions or angles of seat stones



031-0300-64    031-0300-80    031-0300-85    031-0300-56    031-0300-30    KW-437    SX-1672    SX-HOLDER    SX-1702BB    BDS-HOLDER

.437" Pilot, 1 <sup>3</sup> / <sub>16</sub> "x13 Thread Kwik-Way Stone Holders		
	Jobber	Order No.
All Kwik-Way Holders are rebuildable unless noted		
Flex-Drive Stone Holder with Stabilizer & Coupling	\$399.99	031-0300-64
Flex-Drive Stone Holder with Stabilizer	389.99	031-0300-80
Flex-Drive Stone Holder only	349.99	031-0300-85
Hex-Drive Stone Holder w/o Spring Plunger	349.99	031-0300-56
Hex-Drive Stone Holder with Spring Plunger	379.99	031-0300-30
Kwik-Way Style (not rebuildable)	167.99	KW-437

.385" Pilot, 1 <sup>1</sup> / <sub>16</sub> "x16 Thread Sioux-Style Stone Holders			
	OE #	Jobber	Order No.
Short Body (Spline)	1672	\$109.99	SX-1672
Sioux-Style (Spline)	1702	125.99	SX-HOLDER
3/8" Hex Drive	1702BB	179.99	SX-1702BB



Accessories	Jobber	Order No.
Stabilizer Assembly with Bronze Bushing	\$49.99	031-0126-60
Heavy-Duty Twisted Cable Steel Coupling	79.99	031-0304-10
Replacement Hex Drive Body Cap	69.99	031-0302-95
Replacement Spring Plunger Assembly	9.99	031-0313-97
Leather Vibration Reducer (3 pc.) For KW-Holders	11.99	KHW-3
Valve Seat Stone Removal Tool	24.99	KW-SRT

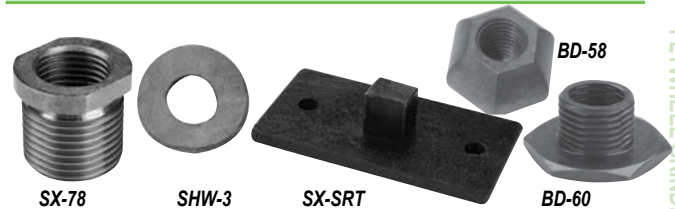

Accessories	Jobber	Order No.
Sioux™ Conversion Bushings 1 <sup>1</sup> / <sub>16</sub> "x16 to 7/8"x14	\$ 9.99	SX-78
Leather Vibration Reducer (3 pc.) For SX-Holders	11.99	SHW-3
Standard Bounce Spring Set (3pc.)	16.99	BSS-100
Valve Seat Stone Removal Tool	24.99	SX-SRT



Rebuild Kits	Jobber	Order No.
<b>For Hex Drive Stone Holder without Spring Plunger</b>	\$189.99	034-0002-00
Includes 2 Bearings, Bearing Sleeve, Bearing Lock Nut, Sleeve Key, Hex Cap & Garter Spring		



Rebuild Kits	Jobber	Order No.
<b>For Hex Drive Stone Holder with Spring Plunger</b>	\$199.99	034-0002-15
Includes 2 Bearings, Bearing Sleeve, Bearing Lock Nut, Sleeve Key, Hex Cap & Spring Plunger Assembly		



Rebuild Kits	Jobber	Order No.
<b>For Flex Drive Stone Holder</b>	\$229.99	034-0003-25
Includes 2 Bearings, Bearing Sleeve, Heavy Duty Flex Coupling, Inner Sleeve Key & Set Screw		
<b>Rebuild kit components are not available individually</b>		

.375" Pilot, 9/16"x16 Thread Black & Decker Stone Holders			
	OE #	Jobber	Order No.
Black & Decker Style	BD-HOLDER	\$199.99	BDS-HOLDER
Includes BD-60 adaptor to convert 9/16"x16 to 11/16"x16 Sioux-style stones			
Accessories	Jobber	Order No.	
Black & Decker 5/8" Hexball 9/16"x24 thread	\$59.99	BD-58	
9/16"-16 to 11/16"-16 Adaptor for Sioux™	8.99	BD-60	



## Grinding Wheel Adaptors

Description	Jobber	Order No.
1 <sup>3</sup> / <sub>16</sub> "-13 (KW) Threaded Stones to 1 <sup>1</sup> / <sub>16</sub> "-16 Threaded Holders (Sioux™, KO Lee)	\$59.99	031-0390-02
1 <sup>3</sup> / <sub>16</sub> "-13 (KW) Threaded Stones to 9/16"-16 Threaded Holders (Black & Decker)	59.99	031-0391-00
1 <sup>3</sup> / <sub>16</sub> "-13 (KW) Threaded Stones to 2 <sup>1</sup> / <sub>32</sub> "-18 Threaded Holders (Kwik-Way)	59.99	031-0393-04
2 <sup>1</sup> / <sub>32</sub> "-18 (KW) Threaded Stones to 1 <sup>3</sup> / <sub>16</sub> "-13 Threaded Holders (Kwik-Way) requires 031-0202-71 Dresser Pilot (above)	59.99	031-1310-65

Billet Aluminum	Jobber	Order No.
Tooling Stand Accommodates tooling using 3/8" or larger pilots. Perfect for stone holders! Room for up to 5 tools.	\$44.99	TS-5

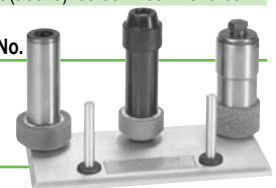

CYLINDER HEAD REBUILDING  
CLEANING, ASSEMBLY & SAFETY  
SHORT BLOCK REBUILDING  
CRANKSHAFT/FLYWHEEL GRINDING  
MISCELLANEOUS TOOLS & SUPPLIES  
BRAKE & TIRE CHANGING TOOLS  
MEASURING TOOLS  
V-TWIN & METRIC HARD PARTS



"We pride ourselves on getting orders to you quickly. Goodson stocks a wide variety of products in our Texas service center so you can receive your order in 3 days or less."

- William, Texas Service Center - 6 years of service

## Precision made wheels – superior performance

We stock more than 40 individual valve refacer wheels, each one designed for a specific machine. Our 4" general purpose wheel for Black & Decker is different from our 4" general purpose wheel for Sioux™. We won't compromise on performance just to simplify our inventory. Your valve refacer requires a certain type of grit, grade and bond and Goodson delivers. All Goodson Valve Refacing Wheels are designed to be used with mineral based grinding oils such as VGO-10 or VGO-SD10. Goodson guarantees all valve refacing wheels against manufacturing defects for 1 year from original purchase date.

Choose from these types: **S** = for grinding Stellite, **T** = for grinding Titanium, **GP** = for general purpose grinding and **CB** = for general purpose grinding of harder materials. Stone color may vary due to manufacturing process.

To Fit	Use	Dia x Ht x Arb	Shape	Type	Color	Fits Models	OE No.	Jobber	Order No.
Black & Decker	Valve	4" x 1" x 5/8"	Offset	GP	Orange	A, B, C, LW, M,	33056	\$ 41.99	GV-146
		4" x 1" x 5/8"	Offset	CB	Blue	A, B, C, LW, M,	Goodson Spec	31.79	GV-146-CB
	Van Dorn	4" x 1" x 5/8"	Offset	S	Ruby	MW, N, NW, NWB	16371	29.99	GV-144
	Stem	5" x 1" x 5/8"	Offset/20°	GP	Pink	P, PC, PCB, T, TD, TG	34131	44.99	GV-156
		4" x 1 1/8" x 1/2"	Cup	GP	Ruby	All models	20939	29.99	GV-145
Comec	Valve	215 x 35 x 76mm	Flared	GP	Gray	VR416, RV-516	7604	154.99	GV-925
	Stem	100 x 50 x 20mm	Cup	GP	White	VR416, RV-516	7606	54.79	GV-928
IDL	Valve	8" x 1 1/4" x 1 1/2"	Flared	GP	White	CG-50,-80,-82, V-90, VR-7000	8230	129.99	GV-823
Sunnen	Valve	8" x 1 1/4" x 1 1/2"	Flared	GP	Gray	CG-50,-80,-82, V-90, VR-7000	VR1703	174.99	GV-825
		8" x 1 1/4" x 1 1/2"	Flared	S	White	CG-50,-80,-82, V-90, VR-7000	Goodson Spec	119.99	GV-821
		8" x 1 1/4" x 1 1/2"	Flared	S	Pink	CG-50,-80,-82, V-90, VR-7000	8230-3	89.99	GV-826
		8" x 1 1/4" x 1 1/2"	Flared	T	Green	CG-50,-80,-82, V-90, VR-7000	VR1704	114.99	GV-827
	Stem	8" x 1 1/4" x 1 1/2"	Flared	GP	Ruby	CG-80, CG-82, V-90, VR-7000	VR1701	104.99	GV-824
Kwik-Way	Valve	4 1/2" x 7/8" x 7/8"	Offset	GP	Black	CV, SK, KK, VC, SV, XC	010-0450-10	57.99	GV-257
		4 1/2" x 7/8" x 7/8"	Offset	S	Gray	CV, SK, KK, VC, SV, XC	010-0457-03	41.79	GV-259
		5" x 7/8" x 7/8"	Offset	GP	Orange	EVS, VS	Goodson Spec	57.99	GV-250
		5" x 7/8" x 7/8"	Offset	GP	White	EVS, VS	Goodson Spec	46.99	GV-251
		5" x 7/8" x 7/8"	Offset	GP	Gray	EVS, VS	010-0509-01	49.99	GV-252
		5" x 7/8" x 7/8"	Offset	T	Green	EVS, VS	010-0508-04	107.99	GV-255
		7" x 1" x 7/8"	Offset	GP	Gray	SVS, SVS-2	010-0709-00	59.99	GV-280
		7" x 1" x 7/8"	Offset	CB	Blue	SVS, SVS-2	Goodson Spec	69.99	GV-280-CB
		7" x 1" x 7/8"	Offset	S	White	SVS, SVS-2	010-0707-50	94.99	GV-281
		7" x 1" x 7/8"	Offset	T	Green	SVS, SVS-2	010-0708-05	169.99	GV-282
		7" x 1" x 7/8"	Offset	T	Green	SVS, SVS-2	Goodson Spec	89.99	GV-282A
		8" x 1 3/8" x 7/8"	Offset	GP	Gray	VL	010-0819-04	97.99	GV-260
Stem	3" x 1 1/4" x 5/8"	Cup	GP	Gray	All but VL	010-0300-05	21.29	GV-237	
	3" x 1 1/4" x 5/8"	Cup	CB	Blue	All but VL	Goodson Spec	25.99	GV-237-CB	

Colors may vary due to manufacturing processes. All valve refacing wheels are guaranteed for 1 year from original purchase date.



### Mineral Based Valve Grinding Oil

- Long-lasting • Cools while grinding
- Removes particles for a better finish
- Inhibits rust • Prevents rancidity, foaming & deposits

Quantity	Jobber	Order No.
1 gallon / 3.79 L	\$ 29.99	VGO-10
5 gallons / 18.93 L	119.99	VGO-50

### Valve Grinding Aid For Titanium, Stainless & Stellite Valves

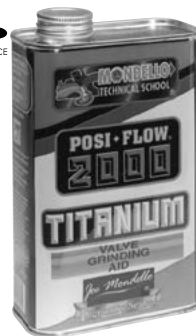

- Not water soluble - add to your mineral based Valve Grinding Oil for better finish on titanium, stainless steel and stellite valves
- Mix ratio: 1:4 • Won't hinder your regular valve grinding process
- Seeks out, and bonds to hot metals
- Ideal for grinding hard metal racing valves • 32 oz. / 946 mL
- Order No. **VGA-T32** Jobber \$42.99



### Severe Duty Valve Refacer Oil

- Mineral Based
- Formulated for **titanium**, Inconel®, stainless steel and stellite valves
- Includes additives to improve cutting performance under high pressure

Size	Jobber	Order No.
1 gallon / 3.79 L	\$ 34.99	VGO-SD10
5 gallons / 18.93 L	174.99	VGO-SD50

CYLINDER HEAD REBUILDING  
CLEANING, ASSEMBLY & SAFETY  
SHORT BLOCK REBUILDING  
CRANKSHAFT/ FLYWHEEL GRINDING  
MISCELLANEOUS TOOLS & SUPPLIES  
BRAKE & TIRE CHANGING TOOLS  
MEASURING TOOLS  
V-TWIN & METRIC HARD PARTS

# Valve Refacing Wheels

Choose the correct profile for your machine and application

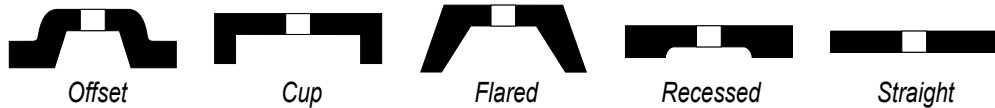

Colors may vary due to manufacturing processes. All valve refacing wheels are guaranteed for 1 year from original purchase date.

To Fit	Use	Dia x Ht x Arb	Shape	Type	Color	Fits Models	OE No.	Jobber	Order No.
KO Lee	Valve	5" x 3/4" x 5/8"	Offset	GP	Gray	All models	OV5GH60	\$ 79.99	<b>GV-658</b>
		5" x 3/4" x 5/8"	Offset	S	White	All models	OV5GH80S	57.99	<b>GV-659</b>
	Stem	4" x 1" x 5/8"	Cup	GP	Gray	K500(C) & K403(C)	RV4KH60	27.99	<b>GV-345</b>
Rottler VR-7	Valve	7" x 1" x 7/8"	Offset	GP	Gray	All but 500 & CRW	Goodson Spec	31.79	<b>GV-345-CB</b>
		7" x 1" x 7/8"	Offset	T	Green		VTRW-8	59.99	<b>GV-280</b>
	Stem	3" x 1 1/4" x 5/8"	Cup	GP	Gray		VTRW-7	169.99	<b>GV-282</b>
Rottler VR-8	Valve	8" x 1 1/4" x 1 1/2"	Flared	GP	Gray		Goodson Spec	169.99	<b>GV-525</b>
	Stem	100 x 50 x 20mm	Cup	GP	White	VR416, RV-516	7606	54.79	<b>GV-928</b>
Skil Snap-On	Valve	5" x 3/4" x 5/8"	Offset	GP	Gray	All models	7556/VW80	79.99	<b>GV-658</b>
		5" x 3/4" x 5/8"	Offset	S	White	All models	VW80S	57.99	<b>GV-659</b>
	Stem	4" x 1" x 5/8"	Cup	GP	Gray	All but Skil 491	7557/VR2M89	27.99	<b>GV-345</b>
Sioux™	Valve	4" x 1" x 5/8"	Cup	CB	Blue	All but 500 & CRW	Goodson Spec	31.79	<b>GV-345-CB</b>
		4" x 1" x 5/8"	Offset	GP	Gray	All but 680, 682, 285, 956	78SP	31.99	<b>GV-147</b>
		4" x 1" x 5/8"	Offset	GP	Black	All but 680, 682, 285, 956	78E	52.99	<b>GV-148</b>
		4" x 1" x 5/8"	Offset	S	Gray	All but 680, 682, 285, 956	78A	37.29	<b>GV-149</b>
		4" x 1" x 5/8"	Offset	S	Ruby	All but 680, 682, 285, 956	Goodson Spec	29.99	<b>GV-144</b>
		4" x 1" x 5/8"	Offset	T	Green	All but 680, 682, 285, 956	Goodson Spec	47.99	<b>GV-150</b>
		5" x 1" x 5/8"	Offset/20°	GP	Pink	Thor 299 & 300	Goodson Spec	44.99	<b>GV-156</b>
		6" x 5/8" x 3/4"	Offset	S	White	685L	186	79.99	<b>GV-186</b>
		7" x 1 1/8" x 1 3/4"	Str./15°	GP	Orange	680, 956, 2001 & 2075	176	54.49	<b>GV-270</b>
		7" x 1 1/8" x 1 3/4"	Str./15°	CB	Blue	680, 956, 2001 & 2075	Goodson Spec	49.99	<b>GV-270-CB</b>
		7" x 1 1/8" x 1 3/4"	Str./15°	S	White	680, 956, 2001 & 2075	177	57.99	<b>GV-271</b>
		7" x 1 1/8" x 1 3/4"	Str./15°	T	Green	680, 956, 2001 & 2075	174	124.99	<b>GV-272</b>
	Stem	4" x 1" x 5/8"	Cup	GP	Gray	All but 682 & 685	81 (73533)	27.99	<b>GV-345</b>
Sunnen (TA) S&D	Valve	6" x 1 1/8" x 3/4"	Flared	GP	Black	VR6500, all S&D	VR602	137.99	<b>GV-766</b>
	Stem	5" x 1 1/2" x 3/4"	Cup	GP	White	VR6500, all S&D	VR601	74.99	<b>GV-755</b>
Winona	Valve	5" x 3/4" x 5/8"	Off./Bev.	GP	Gray	E, Y, YW, X, XA	75399	79.99	<b>GV-658</b>
Van	Valve	5" x 3/4" x 5/8"	Off./Bev.	S	White	K500HM, K403CM	75400	57.99	<b>GV-659</b>
Norman	Stem	4" x 1" x 5/8"	Cup	GP	Gray	All but 500 & CRW	40352	27.99	<b>GV-345</b>
		4" x 1" x 5/8"	Cup	CB	Blue	All but 500 & CRW	Goodson Spec	31.79	<b>GV-345-CB</b>

Colors may vary due to manufacturing processes. All valve refacing wheels are guaranteed for 1 year from original purchase date.

Use VG-STOP for extra long stemmed valves

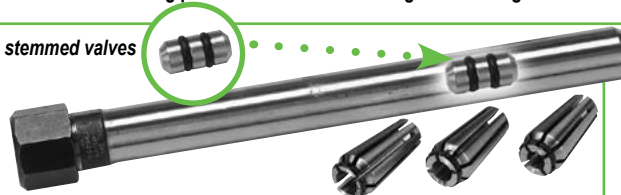

## Adaptor for 1/2" Chucks

- For small diameter valves
- Hardened steel collet holder fits any machine with a 1/2" chuck • Collet seats in retainer nut for fast, easy removal
- Internal stop adjusts with a screwdriver, allowing you to reface an entire set of valves to identical specs quickly
- 3 collet sizes cover range of 4.5 - 6.5mm
- Start with the set then replace collets as needed (**collets will not work without the holder**) • Use the Adaptor Stop to machine longer valve stems

Description	Range	Jobber	Order No.	Incl.
Full Set		\$299.99	<b>UVRC-46</b>	▼
Steel Collet Holder (collets MUST be used)		199.99	<b>UVRC-46R</b>	x
Replacement	4.5 - 5.0 mm (.177"-.196")	37.49	<b>UVRC-5MM</b>	x
Collets	5.0 - 5.5 mm (.196"-.216")	37.49	<b>UVRC-5.5MM</b>	x
	6.0 - 6.5 mm (.236"-.256")	37.49	<b>UVRC-6.5MM</b>	x
Adaptor Stop		13.99	<b>VG-STOP</b>	x

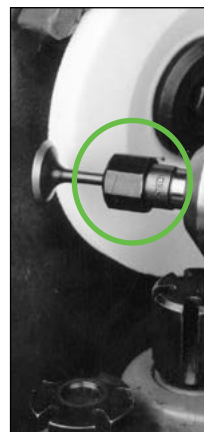

## Valve Stem to Valve Face Concentricity Gauge

- Accurate to .001"
- Features a rugged, positive stop – set it once and do an entire set of valves • Use before grinding to eliminate needless cleaning & machine time • Use after refacing to ensure stem concentricity • Also check pilots and other small parts for concentricity
- For stems as small as 4mm
- Order No. **VCG-16** Jobber \$239.99



CYLINDER HEAD REBUILDING  
CLEANING, ASSEMBLY & SAFETY  
SHORT BLOCK REBUILDING  
CRANKSHAFT/ FLYWHEEL GRINDING  
MISCELLANEOUS TOOLS & SUPPLIES  
BRAKE & TIRE CHANGING TOOLS  
MEASURING TOOLS  
V-TWIN & METRIC HARD PARTS



"At Goodson, we're trained to know your business. Weekly training sessions are held for our entire staff to help us better understand your work so we can provide you with the best possible service."

- Anne, Goodson Accounting Department - 12 years of service

# Piloted Core Drills and Reamers

• CNC-machined to .0003" T.I.R. or less • Ideal for any Bridgeport-type (collet driven) machine • Use dry at 175 to 225 RPM

## Piloted Core Drills

- Center accurately in the guide • Cutting angle prevents the bit from wandering due to irregular guide wear • Flutes are designed to enlarge bores quickly • Manufactured to close tolerances of concentricity

## Precision Reamers

- Pilot size is carefully matched to the OD of the related core drill • Assures accurate location of the reamer for smooth, vibration free operation • Gives proper interference fit to match manufacturer specifications

### Core Drills

	OD	Pilot	OE No.	Jobber	Order No.
DCM Tech,	.4687"	.312"	DP-1550	\$109.99	DPP-1511B
Peterson /	.4687"	.344"	66-02138, DP-1511	109.99	DPP-1511
Kansas	.4687"	.375"	66-02140, DP-1530	109.99	DPP-1530
Instruments	.5312"	.375"	DP-1730	109.99	DPP-1530A
1/2" Round	.5937"	.375"	66-02144, DP-1930	109.99	DPP-1970B
Shank	.5937"	.438"	66-02145, DP-1970	109.99	DPP-1970
Sunnen™ /	.490"	.312"	VGS-156A	109.99	DTA-2082B
Tobin-Arp	.490"	.343"	VGS-152A	109.99	DTA-2082
1/2" with Flat	.490"	.371"	VGS-153A	109.99	DTA-2083
Winona	.4687"	.344"	804206	109.99	DD-1532-G
Van Norman	.4687"	.375"	804207	109.99	DD-1532A-G
IDL /	.475"	.341"	501003	99.99	DVN-2
Van Norman	.475"	.375"	501004	99.99	DVN-3
5/16" Sq. Drive					
Universal	.429"	7mm		155.49	CCD-59
.429" Round	.429"	7mm		155.49	CCD-59
Shank	.429"	7mm		155.49	CCD-59
	.541"	8mm		155.49	CCD-550

### Core Reamers

	OD	OE No.	Jobber	Order No.
	.500"	66-02147, RR-115	\$109.99	DRR-115
	.500"	66-02147, RR-115	109.99	DRR-115
	.500"	66-02147, RR-115	109.99	DRR-115
	.5625"	66-02148, RR-916	109.99	DRR-916
	.625"	66-02149, RR-519	109.99	DRR-519
	.625"	66-02149, RR-519	109.99	DRR-519
	.500"	VGS-162A	109.99	DRT-2097
	.500"	VGS-162A	109.99	DRT-2097
	.500"	VGS-162A	109.99	DRT-2097
	.500"	804237	99.99	DR-500-G
	.500"	804237	99.99	DR-500-G
	.500"	501011	109.99	DRV-79
	.500"	501011	109.99	DRV-79
	.4365"	Use for Ford 6.0L Diesel	129.99	FCR-60-1
	.4375"	Use for Ford 6.0L Diesel	129.99	FCR-60
	.4995"	Use for Cummins Diesel	155.49	CCR-59
	.562"	.500" pilot	155.49	CCR-562B
	.550"	.540" pilot	155.49	CCR-550

Note: For the best performance, Core Drills and Reamers should be used in matched pairs. If you order a drill slightly smaller or larger than the OE specification to fit your machine, please order the matching reamer listed immediately to the right of the drill in the table.

CYLINDER HEAD  
REBUILDING

CLEANING,  
ASSEMBLY & SAFETY

CRANK  
FLYWHEEL

MISCELLANEOUS  
TOOLS & SUPPLIES

BRAKE & TIRE  
CHANGING TOOLS

MEASURING  
TOOLS

V-TWIN & METRIC  
HARD PARTS

V-TWIN & METRIC  
HARD PARTS

24

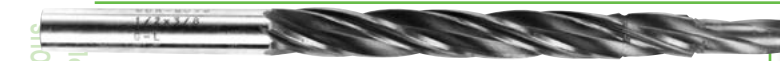

## High Speed Steel Core Drill/Reamers

- Save time – drill and ream in a single pass
- Top-quality, high speed steel
- Prepares the guide bore for standard OD valve guide inserts
- Several shank designs to fit most Seat & Guide machines

**tech tips**  
from the techxperts™

For best results,  
limit speed to  
175 RPM

Fits	Size	mm	Jobber	Order No.
Winona Van Norman	.343" x .500"	8.7x12.7	\$197.99	CDR-6055G
.468" flat				
Tobin-Arp & Sunnen	.343" x .500"	8.7x12.7	197.99	CDR-6105G
Peterson and K.I.	.343" x .500"	8.7x12.7	197.99	CDR-6196G
1/2" round shank	.375" x .500"	9.5x12.7	197.99	CDR-6197G
Kwik-Way and DCM	.343" x .500"	8.7x12.7	197.99	CDR-6211G
1/2" round shank	.375" x .500"	9.5x12.7	197.99	CDR-6212G
Serdi	.275" x .437"	7.0x11.1	197.99	CDR-7192G
3/8" with flat	.275" x .500"	7.0x12.7	197.99	CDR-7193G
	.312" x .437"	7.9x11.1	197.99	CDR-7194G
	.312" x .500"	7.9x12.7	197.99	CDR-7195G
	.343" x .500"	8.7x12.7	197.99	CDR-7196G
	.375" x .500"	9.5x12.7	197.99	CDR-7197G
Cobalt Core Drills/ Reamers	Size	mm	Jobber	Order No.
1/2" round shank	.275" x .437"	7.00x11.1	\$197.99	CDR-274-CB
	.275" x .500"	7.00x12.7	197.99	CDR-275-CB
<b>new</b>	.311" x .5628"	7.90x14.3	197.99	CDR-563-CB
	.312" x .500"	7.92x12.7	197.99	CDR-312-CB
	.343" x .500"	8.71x12.7	197.99	CDR-343-CB
	.373" x .625"	9.47x16.5	197.99	CDR-625-CB
	.375" x .500"	9.53x12.7	197.99	CDR-375-CB

## Check these other tools for diesel applications

Air Powered Valve Guide Drivers	.....page 30
Valve Guides	.....page 30
Valve Seals	.....page 35
Pneumatic Valve Spring Compressor	.....page 36
Heat Tabs	.....page 52

## Valve Guide Tooling For 24 Valve, 7mm Cummins

- To replace integral guides used in this diesel cylinder head
- Replacement guides are .502/.511" stepped to use with OE or replacement seals below

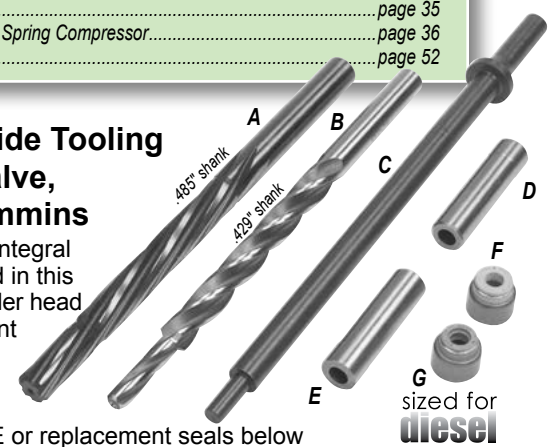

Description	Jobber	Order No.	Includes
Complete Kit	\$399.99	CVG-KIT	▼
Tooling Kit Only	299.99	CVG-59KIT	▼
A Core Reamer (.426" pilot, .485" shank)	155.49	CCR-59	1 1
B Core Drill (7mm pilot, .429" shank)	155.49	CCD-59	1 1
C Guide Driver (7.0mm)	22.99	PHL-2235-G	1 1
D Cast Iron Valve Guide (Exhaust)	3.29	CIG-3022	12
E Cast Iron Valve Guide (Intake)	3.29	CIG-3021	12
F Exhaust Seals (12 pk.)	13.99	CVS-59E	1
G Intake Seals (12 pk.)	13.99	CVS-59I	1

## tech tips

from the techxperts™

Use WSR-41-3-G (1/8" sq.) or WSR-41-4-G (3/16" sq.) with WSR-41-7-G (3/8" drill adaptor). Clamp 3/8" drive in drill to drive reamers directly. See page 34 for ordering information.

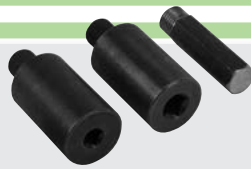

### Small Reamers for Cast Iron or Bronze

Premium quality reamers with tough cobalt flutes for long life in cast iron or bronze.

Once used on cast iron, do NOT use **tech tips** on bronze.

1/8" Square Drive		
Inch	mm	Order No.
.1565"	3.98	MR-156
.1575"	4.00	MR-4MM
.1585"	4.03	MR-158
.1760"	4.47	MR-176
.1771"	4.50	MR-4.5MM
.1780"	4.52	MR-178
.1960"	4.98	MR-196
.1968"	5.00	MR-5.0MM
.1980"	5.03	MR-198

Jobber \$74.99

### Titanium Coated Cobalt Reamers

- Smooth and precise
- Less brittle than carbide
- For cast iron
- **Not for hardened or bronze guides**

3/16" Square Drive		
Inch	mm	Order No.
.2165"	5.50	TNR-5.5MM-B
.236"	6.00	TNR-6MM-B
.2755"	7.00	TNR-7MM-B
1/4" Square Drive		
Inch	mm	Order No.
.312"	7.92	TNR-312-B
.315"	8.00	TNR-8MM-B
.341"	8.66	TNR-341-B
.342"	8.69	TNR-342-B
.343"	8.71	TNR-343-B
.344"	8.74	TNR-344-B
.354"	9.00	TNR-9MM-B
.373"	9.47	TNR-373-B
.374"	9.50	TNR-374-B
.375"	9.52	TNR-375-B
.377"	9.58	TNR-377-B

Jobber \$82.99

## tech tips

from the techxperts™

For best results always use carbide reamers with Bronze Reaming Oil (BW-303A-G)

### Solid Carbide Valve Guide Reamers Specifically Designed For Use Only With Bronze Guides

- Features an extended pilot and multi-fluted design so you can size guides perfectly
- One size allows you to fit both intake & exhaust when using AV&V valves and guides
- 300 to 400 RPM is recommended
- **DO NOT** use on cast iron

Dia.	Jobber	Order No.	Dia.	Jobber	Order No.
4.5mm	\$189.99	HGR-4.5MM	.3140"	\$269.99	HGR-3140
5.0mm	189.99	HGR-5.0MM	8.0mm	269.99	HGR-8MM
5.5mm	189.99	HGR-5.5MM	.3410"	269.99	HGR-3410
6.0mm	189.99	HGR-6MM	.3420"	269.99	HGR-3420
6.6mm	269.99	HGR-6.6MM	.3425"	269.99	HGR-3425
.2750"	269.99	HGR-2750	.3430"	269.99	HGR-3430
7.0mm	269.99	HGR-7MM	.3435"	269.99	HGR-3435
.2761"	269.99	HGR-2761	.3440"	269.99	HGR-3440
.2766"	269.99	HGR-2766	.3450"	269.99	HGR-3450
.3100"	269.99	HGR-3100	9.0mm	269.99	HGR-9MM
.3110"	269.99	HGR-3110	.3720"	269.99	HGR-3720
.3115"	269.99	HGR-3115	.3730"	269.99	HGR-3730
.3120"	269.99	HGR-3120	.3740"	269.99	HGR-3740
.3130"	269.99	HGR-3130	.3782"	269.99	HGR-3782

Due to the characteristics of carbide, we can only guarantee the reamer's dimensional accuracy.



## tech tips Ream dry

from the techxperts™

### High Speed Finish Reamers Exclusively for Cast Iron

Precision size cast iron guides. Piloted and made from the finest tempered steel. With proper care, these reamers will accurately size multiple guides without losing their efficient cutting action. **NOT for hardened or bronze guides.**

3/16" Square Drive				1/4" Square Drive				1/4" Square Drive			
Inch	mm	Jobber	Order No.	Inch	mm	Jobber	Order No.	Inch	mm	Jobber	Order No.
.2165"	5.50	\$41.99	WR-5.5MM-G	.316"	8.03	\$44.99	WR-316-G	.375"	9.52	\$47.99	WR-375-G
.217"	5.51	41.99	WR-217-G	.317"	8.05	44.99	WR-317-G	.376"	9.55	47.99	WR-376-G
.218"	5.54	41.99	WR-218-G	.318"	8.08	44.99	WR-318-G	.377"	9.58	47.99	WR-377-G
.236"	6.00	41.99	WR-6MM-G	.327"	8.31	44.99	WR-327-G	.378"	9.60	47.99	WR-378-G
.250"	6.35	41.99	WR-250-G	.328"	8.33	44.99	WR-328-G	.379"	9.63	47.99	WR-379-G
.256"	6.50	41.99	WR-6.5MM-G	.334"	8.48	44.99	WR-8.5MM-G	.380"	9.65	47.99	WR-380-G
.258"	6.55	41.99	WR-258-G	.340"	8.64	44.99	WR-340-G	.386"	9.80	47.99	WR-386-G
.259"	6.58	41.99	WR-259-G	.341"	8.66	44.99	WR-341-G	.388"	9.86	47.99	WR-388-G
.260"	6.60	41.99	WR-260-G	.342"	8.69	44.99	WR-342-G	.390"	9.91	47.99	WR-390-G
.261"	6.63	41.99	WR-261-G	.343"	8.71	44.99	WR-343-G	.393"	9.98	47.99	WR-393-G
.273"	6.93	41.99	WR-273-G	.3435"	8.72	44.99	WR-3435-G	.394"	10.00	47.99	WR-10MM-G
.274"	6.96	41.99	WR-274-G	.344"	8.74	44.99	WR-344-G	.395"	10.03	47.99	WR-395-G
.275"	6.99	41.99	WR-275-G	.345"	8.76	44.99	WR-345-G	.404"	10.26	49.99	WR-404-G
.2755"	7.00	41.99	WR-7MM-G	.346"	8.79	44.99	WR-346-G	.405"	10.29	49.99	WR-405-G
.276"	7.01	41.99	WR-276-G	.347"	8.81	44.99	WR-347-G	.406"	10.31	52.99	WR-406-G
.277"	7.03	41.99	WR-277-G	.348"	8.84	44.99	WR-348-G	.433"	11.00	52.99	WR-11MM-G
.278"	7.06	44.99	WR-278-G	.348"	8.84	44.99	WR-348-G	.435"	11.05	52.99	WR-435-G
.281"	7.14	44.99	WR-281-G	.354"	9.00	44.99	WR-9MM-G	.436"	11.07	52.99	WR-436-G
				.355"	9.02	44.99	WR-355-G	.437"	11.10	52.99	WR-437-G
				.356"	9.04	44.99	WR-356-G	.453"	11.51	52.99	WR-453-G
				.358"	9.09	47.99	WR-358-G	.472"	12.00	52.99	WR-12MM-G
				.371"	9.42	47.99	WR-371-G	.496"	12.60	54.99	WR-496-G
				.372"	9.45	47.99	WR-372-G	.499"	12.67	54.99	WR-499-G
				.373"	9.47	47.99	WR-373-G	.500"	12.70	54.99	WR-500-G
				.374"	9.50	47.99	WR-374-G				



**Goodson  
exclusive**



**No more guesswork!**  
Easy to read and easy to use feed knob. Each witness mark equals approximately .001" increase in hone diameter.

- ▶ Largest range of any guide hone
- ▶ Diamond abrasive delivers the finish required for today's valve guides
- ▶ Balanced yoke and body for symmetrical honing at any speed
- ▶ Size range replaces over 80 reamers!

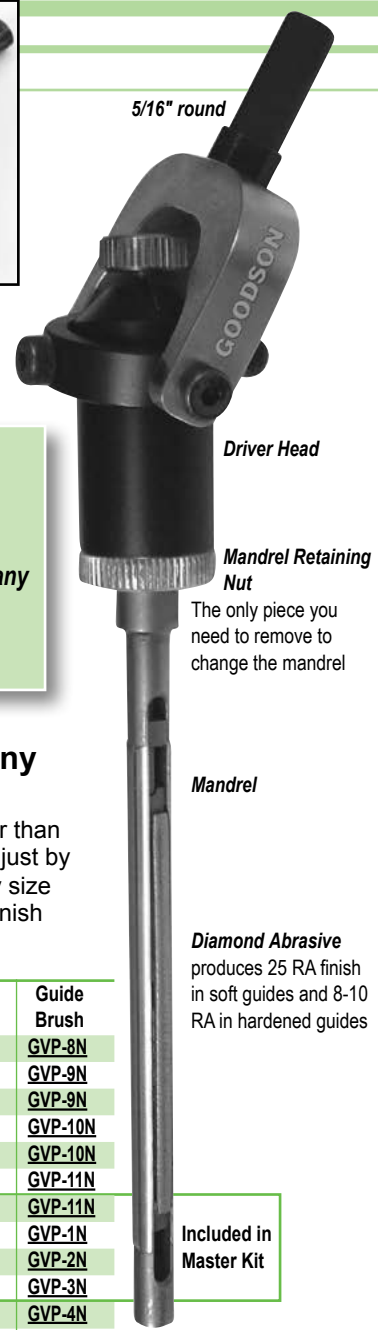

5/16" round

**Driver Head**

**Mandrel Retaining Nut**

The only piece you need to remove to change the mandrel

**Mandrel**

**Diamond Abrasive** produces 25 RA finish in soft guides and 8-10 RA in hardened guides

Included in Master Kit

## Hyper-Finish Diamond Sizing System has the largest range of any guide hone on the market today

Goodson's exclusive Hyper-Finish Diamond Valve Guide Sizing System is bigger and better than ever. With this easy-to-use system you can size guides from .154" to .566" (3.9 -14.40mm) just by switching out mandrels. Mandrels also sold individually. The Drive Head (**HF-100**) fits every size mandrel assembly shown in the chart below and features a Quick Change set-up. Hyper-Finish Tooling is NOT interchangeable with Sunnen® (p. 28).

Size	Range		Mandrel Assembly (abrasive & mandrel)	Abrasive Length	Abrasive Only	Mandrel Only	Drive Head	Guide Brush
	inch	mm						
4.0mm	.154"-.164"	3.90 - 4.15mm	\$319.99 <b>HFM-154C</b>	20mm	<b>HFS-154</b>	<b>HFM-154</b>	<b>HF-100</b>	<b>GVP-8N</b>
4.5mm	.173"-.183"	4.40 - 4.90mm	319.99 <b>HFM-173C</b>	20mm	<b>HFS-173</b>	<b>HFM-173</b>	<b>HF-100</b>	<b>GVP-9N</b>
5.0mm	.193"-.203"	4.90 - 5.15mm	319.99 <b>HFM-193C</b>	40mm	<b>HFS-193</b>	<b>HFM-193</b>	<b>HF-100</b>	<b>GVP-9N</b>
5.5mm	.212"-.232"	5.40 - 5.90mm	319.99 <b>HFM-212C</b>	40mm	<b>HFS-212</b>	<b>HFM-212</b>	<b>HF-100</b>	<b>GVP-10N</b>
6.0mm	.232"-.253"	5.90 - 6.40mm	299.99 <b>HFM-232C</b>	40mm	<b>HFS-232</b>	<b>HFM-232</b>	<b>HF-100</b>	<b>GVP-10N</b>
6.5mm	.251"-.271"	6.40 - 6.90mm	299.99 <b>HFM-251C</b>	40mm	<b>HFS-251</b>	<b>HFM-251</b>	<b>HF-100</b>	<b>GVP-11N</b>
7.0mm	.271"-.311"	6.90 - 7.90mm	384.99 <b>HFM-271C</b>	80mm	<b>HFS-271</b>	<b>HFM-271</b>	<b>HF-100</b>	<b>GVP-11N</b>
.312"	.307"-.347"	7.80 - 8.80mm	299.99 <b>HFM-307C</b>	80mm	<b>HFS-307</b>	<b>HFM-307</b>	<b>HF-100</b>	<b>GVP-1N</b>
.343"	.334"-.374"	8.50 - 9.50mm	299.99 <b>HFM-344C</b>	80mm	<b>HFS-344</b>	<b>HFM-344</b>	<b>HF-100</b>	<b>GVP-2N</b>
.375"	.350"-.389"	8.90 - 9.90mm	299.99 <b>HFM-350C</b>	80mm	<b>HFS-350</b>	<b>HFM-350</b>	<b>HF-100</b>	<b>GVP-3N</b>
10.0mm	.389"-.429"	9.90 - 10.90mm	299.99 <b>HFM-394C</b>	80mm	<b>HFS-394</b>	<b>HFM-394</b>	<b>HF-100</b>	<b>GVP-4N</b>
11.0mm	.429"-.507"	10.90 - 12.90mm	299.99 <b>HFM-429C</b>	80mm	<b>HFS-429</b>	<b>HFM-429</b>	<b>HF-100</b>	<b>GVP-5N</b>
12.5mm	.488"-.566"	12.40 - 14.40mm	599.99 <b>HFM-488C</b>	80mm	—	—	<b>HF-100</b>	<b>GVP-6N</b>
			<b>Jobber</b>	\$149.99	\$229.99	\$329.99	\$6.79	

## Choose from the Standard Master Kit or Build Your Own!

**Standard Master Kit includes:** Driver Head, 4-Mandrel Assemblies (see chart above), 4-Nylon Valve Guide Brushes (7mm to 3/8") and 8 oz. Diamond Honing Oil. Order No. **HF-KIT** Jobber \$1499.99

**Custom Kit includes:** Driver Head, 4-Mandrel Assemblies (select from chart above, **excluding 12.5mm**), 4-Nylon Valve Guide Brushes (you pick the sizes - see chart above) and 8 oz. Diamond Honing Oil. Order No. **HF-KIT-CUSTOM** Jobber \$1499.99



### Diamond Honing Oil

For high pressure honing

Size	Jobber	Order No.
8 oz./237mL	\$ 5.29	<b>DHO-8</b>
1 Gallon/3.79L	38.99	<b>DHO-10</b>
5 Gallons/18.93L	174.99	<b>DHO-50</b>

110V model features a weather-proof electrical box with switch and outlet to power your electric drill or other tooling



Adjustable hose lets you direct coolant to right where you need it

18 1/2" diameter holes and 2-1" diameter holes drilled in the top plate provide ample tool storage

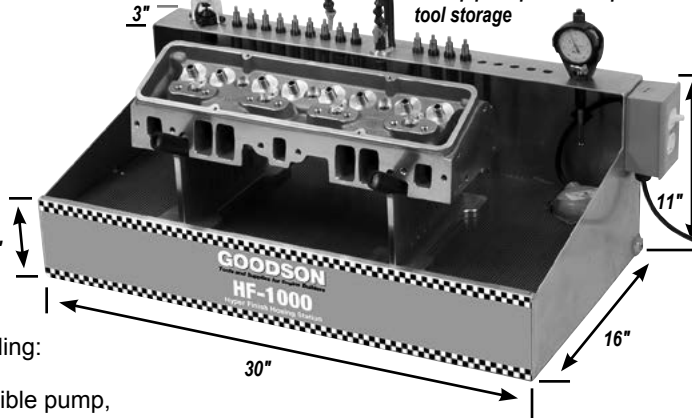

## Hyper-Finish Honing Station

You asked for it and Goodson delivered!

This Goodson designed honing station incorporates the features you requested in a bench top honing station including:

- Large 5-gallon capacity coolant sump
- Integral high output pump - 1/150 HP oil filled submersible pump, 115V 60 cycle, single phase heavy-duty motor
- Built-in 115V adjustable work-light on 110V model only
- All aluminum construction for durability and easy cleaning
- Perforated steel grate allows used coolant through to recirculate
- Removable steel grate for easy maintenance
- Built-in, easy-to-reach storage for tools

Buy the complete kit and save!

**American Made**

Description	Jobber	Order No.	Incl.
Complete 110V Honing Station Kit	\$1039.99	HF-1000KIT	▼
Complete 220V Honing Station Kit (w/o light or box)	1099.99	HF-1000E-KIT	▼
Honing Station Only - 110V	739.99	HF-1000	x
Honing Station Only - 220V (w/o light)	799.99	HF-1000E	x
Universal Head Holders	129.99	HH-200	x x
Replacement Pump	139.99	HF-PUMP	x x
5 Gallons Diamond Honing Oil	174.99	DHO-50	x x

Perforated steel grate lets oil through and can be removed for cleaning

On/Off Switch on 110V model activates the built-in pump and work-light

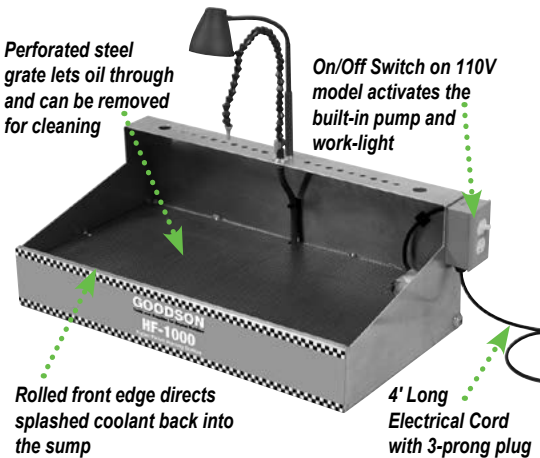

Rolled front edge directs splashed coolant back into the sump

## Valve Guide OD Machining Tool

Does 3 jobs at one time!

- Face the guide top to the correct size
- Sizes the guide OD for press-on seals
- Chamfers the top to prevent seal damage
- Cutters & pilots are interchangeable and chuck into any portable drill, drill press or seat & guide machine



Valve Spring Seat Cutters on page 40



## Valve Guide OD Chamfer Tool

- Improve oil deflection
- Universal cutter chamfers any OD from 1/4" to 5/8" (6.35-15.9mm)
- Most precise when used in a Seat and Guide Machine
- Order No. **GCT-35**  
Jobber \$79.99



### Individual Cutters

Guide OD	Order No.
.415"	10.5 <b>VSC-415</b>
.428"	10.8 <b>VSC-428</b>
.475"	12.1 <b>VSC-475</b>
.495"	12.6 <b>VSC-495</b>
.500"	12.7 <b>VSC-500</b>
.530"	13.5 <b>VSC-530</b>
.562"	14.3 <b>VSC-562</b>
.625"	15.9 <b>VSC-625</b>

Jobber \$71.99

### Pilots

Guide ID	Order No.
9/32"	7.0 <b>VP-TMM</b>
5/16"	7.9 <b>VP-312</b>
11/32"	8.7 <b>VP-343</b>
3/8"	9.5 <b>VP-375</b>

Jobber \$27.99

### Cutter and Pilot Assemblies

Guide OD	Pilot Size	Order No.
.415"	5/16" 7.9	<b>VSC-415312</b>
.428"	5/16" 7.9	<b>VSC-428312</b>
.475"	5/16" 7.9	<b>VSC-475312</b>
.500"	5/16" 7.9	<b>VSC-500312</b>
.500"	11/32" 8.7	<b>VSC-500343</b>
.500"	3/8" 9.5	<b>VSC-500375</b>
.530"	5/16" 7.9	<b>VSC-530312</b>
.530"	11/32" 8.7	<b>VSC-530343</b>
.530"	3/8" 9.5	<b>VSC-530375</b>
.562"	11/32" 8.7	<b>VSC-562343</b>
.562"	3/8" 9.5	<b>VSC-562375</b>
.625"	3/8" 9.5	<b>VSC-625375</b>

Jobber \$94.99



## Valve Guide Top Collar

- Supports guide top during machining
- Protects against damage or breakage
- Ideal for high-performance work, and for installing Bronze-Wall® guide inserts or thin-wall liners

Size	Range	Order No.
.500"	.496" - .504"	<b>VGC-502</b>
.530"	.526" - .534"	<b>VGC-530</b>
.566"	.562" - .570"	<b>VGC-566</b>

Jobber \$8.99



CYLINDER HEAD REBUILDING  
CLEANING, ASSEMBLY & SAFETY  
SHORT BLOCK REBUILDING  
CRANK/SHAFT/ FLYWHEEL GRINDING  
MISCELLANEOUS TOOLS & SUPPLIES  
BRAKE & TIRE CHANGING TOOLS  
MEASURING TOOLS  
V-TWIN & METRIC HARD PARTS

full service  
...fast



"If any of our products aren't satisfactory, we want you to send it back...we have a no hassle return policy. Just send it back, freight pre-paid within 30 days and we'll exchange it, fix it or credit your account for the amount of the purchase."

- Nancy, Warehouse Manager, 21 years of service



Truing Sleeve

Adaptor

P-180  
Hone Head

Honing Stone

Wedge (included with  
Mandrel)

Mandrel

## Valve Guide Hone Set

- Sets-up fast • Easy to use!
- Produces straight, round holes for top-quality work
- Ideal for high-performance applications
- Use a low RPM, 1/2" drill for driving power (200 RPM max.)
- Sunnen® tooling is NOT interchangeable with Goodson Hyper-Finish (page 26)

Description	Jobber	Order No.
Sunnen Honall® Valve Guide Hone Set	\$757.04	P-190
Includes: Head & Driver. Mandrels & Sleeves (1 of ea. for sizes - 5/16", 1/2", 3/8", & 7/16")		
Adaptors: (1) PK10-A & (1) PK12-A. Stones L10-J69 & L12-J67. Case & instructions		
Sunnen Honall® Valve Guide Hone Head & Driver only	\$324.44	P-180

### tech tips

from the techxperts™

**Ordering Information:** The head and driver are interchangeable with the adaptors. Only one head and driver is required. Mandrels are available to cover all popular sizes. Please select from the parts in the photo above and order per size range desired. We suggest you have an adaptor for each mandrel to save change-over time between sizes.



### BL Mandrels (Order Mandrel, Sleeve, Stones, Adaptor & Stone Retainer Separately)

Size	Inch	mm	Mandrel		Sleeve		Roughing Stones		Finishing Stones		Adaptor		Stone Retainer	
			Jobber	Order No.	Jobber	Order No.	Jobber	Order No.	Jobber	Order No.	Jobber	Order No.	Jobber	Order No.
3/16"	.185"-.190"	4.7-4.8	\$39.99	BL6-185CS	\$ 9.57	S-185	\$61.79	L6-J47 (12)	\$61.79	L6-J67 (12)	\$72.09	PSK6-A*	\$10.60	LN-3087C
	.190"-.195"	4.8-4.9	39.99	BL6-190CS	9.57	S-190	61.79	L6-J47 (12)	61.79	L6-J67 (12)	72.09	PSK6-A*	10.60	LN-3087C
5mm	.195"-.200"	4.9-5.1	39.99	BL6-195CS	9.57	S-195	61.79	L6-J47 (12)	61.79	L6-J67 (12)	72.09	PSK6-A*	10.60	LN-3087C
	.210"-.215"	5.3-5.5	39.99	BL6-210CS	9.57	S-210	61.79	L6-J47 (12)	61.79	L6-J67 (12)	72.09	PSK6-A*	10.60	LN-3087C
5.5mm	.215"-.220"	5.5-5.6	39.99	BL6-215CS	9.57	S-215	61.79	L6-J47 (12)	61.79	L6-J67 (12)	72.09	PSK6-A*	10.60	LN-3087C
	.225"-.230"	5.7-5.8	39.99	BL6-225CS	9.57	S-225	61.79	L6-J47 (12)	61.79	L6-J67 (12)	72.09	PSK6-A*	10.60	LN-3087C
6mm	.230"-.235"	5.8-6.0	39.99	BL6-230CS	9.57	S-230	61.79	L6-J47 (12)	61.79	L6-J67 (12)	72.09	PSK6-A*	10.60	LN-3087C
	.235"-.240"	6.0-6.1	39.99	BL6-235CS	9.57	S-235	61.79	L6-J47 (12)	61.79	L6-J67 (12)	72.09	PSK6-A*	10.60	LN-3087C
1/4"	.245"-.250"	6.2-6.4	39.99	BL8-245AS	9.57	S-245	37.01	L8-J47 (6)	37.01	L8-J67 (6)	73.12	PK8-A	—	—
	.250"-.255"	6.4-6.5	39.99	BL8-250AS	9.57	S-250	37.01	L8-J47 (6)	37.01	L8-J67 (6)	73.12	PK8-A	—	—
6.6mm	.255"-.260"	6.5-6.6	39.99	BL8-255AS	9.57	S-255	37.01	L8-J47 (6)	37.01	L8-J67 (6)	73.12	PK8-A	—	—
	.270"-.275"	6.8-7.0	39.99	BL8-270AS	9.57	S-270	37.01	L8-J47 (6)	37.01	L8-J67 (6)	73.12	PK8-A	—	—
7mm	.275"-.280"	7.0-7.1	39.99	BL8-275AS	9.57	S-275	37.01	L8-J47 (6)	37.01	L8-J67 (6)	73.12	PK8-A	—	—
	5/16" ♦	.308"-.316"	7.8-8.0	41.99	BL10-308AS	9.57	S-308	42.22	L10-J47 (6)	42.22	L10-J69 (6)	73.12	PK10-A	—
1 1/32" ♦	.339"-.347"	8.6-8.8	41.99	BL10-339AS	9.57	S-339	42.22	L10-J47 (6)	42.22	L10-J69 (6)	73.12	PK10-A	—	—
	23/64"	.354"-.362"	9.0-9.2	41.99	BL10-354AS	9.57	S-354	42.22	L10-J47 (6)	42.22	L10-J69 (6)	73.12	PK10-A	—
3/8" ♦	.370"-.385"	9.4-9.8	44.29	BL12-370AS	13.69	S-370	42.22	L12-J47 (6)	42.22	L12-J67 (6)	73.12	PK12-A	—	—
	7/16" ♦	.432"-.447"	11.0-11.4	44.29	BL12-432AS	13.69	S-432	42.22	L12-J47 (6)	42.22	L12-J67 (6)	73.12	PK12-A	—

♦ Included in set \*NOTE: Remove the stone retainer included with the PSK6-A and replace with LN-3087C for valve guide honing

## Ultra-Finish Plateau Soft Honers

- Use AFTER guide honing to remove microscopic peaks and cuffs without enlarging the guide ID
- Abrasive impregnated nylon bristles

Hole Diameter	Hone Dia.	Head Length	Overall Length	Jobber	Order No.
.2187"	5.5	.241"	1.00"	\$ 9.79	UF-5.5MM
.2500"	6.4	.275"	1.25"	9.79	UF-6.4MM
.2813"	7.0	.309"	1.25"	10.99	UF-7MM
.3125"	8.0	.343"	1.25"	10.99	UF-8MM
.3437"	9.0	.378"	1.25"	10.99	UF-9MM
.3750"	10.0	.413"	1.25"	10.99	UF-10MM
.4375"	11.0	.481"	1.25"	10.99	UF-11MM
.4688"	12.0	.516"	1.25"	10.99	UF-12MM
.5000"	13.0	.550"	1.50"	12.29	UF-13MM



## 6 Piece Valve Guide Flex-Hone® Set

- Kit includes the most popular sizes for valve guide work
- 240 Grit Silicon-Carbide

Size	mm	OAL	Jobber	Order No.	Incl.
6 Pc. Valve Guide Kit			\$84.99	VGF-KIT	▼
1/4"	6.4	8"	\$20.99	VGF-6.4MM	x
5/16"	7.0	8"	20.99	VGF-7MM	x
3/8"	8.0	8"	20.99	VGF-8MM	x
1/2"	9.0	8"	20.99	VGF-9MM	x
5/8"	10.0	8"	20.99	VGF-10MM	x
3/4"	11.0	8"	20.99	VGF-11MM	x

More Valve Guide Flex-Hones® on page 72



CYLINDER HEAD REBUILDING  
CLEANING, ASSEMBLY & SAFETY  
SHORT BLOCK REBUILDING  
CRANKSHAFT/ FLYWHEEL GRINDING  
MISCELLANEOUS TOOLS & SUPPLIES  
BRAKE & TIRE CHANGING TOOLS  
MEASURING TOOLS  
V-TWIN & METRIC HARD PARTS

1° negative angle prevents guides from spreading

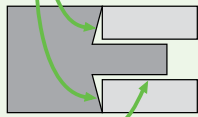

Proper clearance for best contact and easy removal

# Valve Guide Replacement

## Valve Guide Drivers

- Corrosion-resistant finish
- Rockwell hardness of 45-50
- Pilots are slightly smaller than guide ID for easy removal

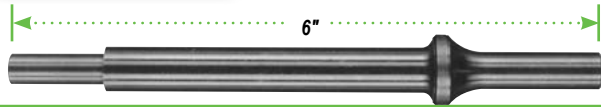

Powered Drivers					
Standard Sizes			Jobber	Order No.	Incl.
4-piece Kit			\$62.99	PH-2226-G	▼
Guide ID /mm	Driver OD	Pilot			
.312" / 7.92	.487" / 12.4	.300" / 7.62	\$19.99	PH-2228A-G	
.312" / 7.92	.423" / 10.7	.304" / 7.72	19.99	PH-2228-G	x
.343" / 8.71	.487" / 12.4	.337" / 8.56	19.99	PH-2229-G	x
.372" / 9.47	.487" / 12.4	.367" / 9.32	19.99	PH-2231-G	x
.437" / 11.10	.612" / 15.5	.429" / 10.90	19.99	PH-2230-G	x
Metric Sizes			Jobber	Order No.	Incl.
6-piece Kit			\$94.99	PH-2600-G	▼
Guide ID /in.	Driver OD	Pilot			
5.0mm / .196"	9.0 / .355"	4.75 / .187"	\$19.99	PH-2250-G	x
5.5mm / .217"	10.5 / .412"	5.21 / .205"	19.99	PH-2255-G	x
6.0mm / .236"	10.5 / .412"	5.72 / .225"	19.99	PH-2260-G	x
6.6mm / .260"	11.8 / .463"	6.30 / .248"	19.99	PH-2234-G	x
7.0mm / .275"	11.0 / .432"	6.60 / .260"	19.99	PH-2235-G	x
8.0mm / .315"	11.7 / .462"	7.80 / .307"	19.99	PH-2236-G	x
9.0mm / .353"	12.4 / .487"	8.81 / .347"	19.99	PH-2237-G	
10mm / .393"	15.5 / .612"	8.56 / .387"	19.99	PH-2238-G	
11mm / .433"	15.5 / .612"	10.85 / .427"	19.99	PH-2239-G	

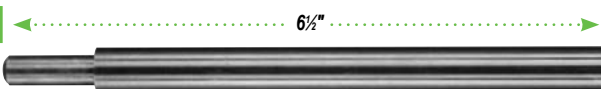

Manual Drivers					
Standard Sizes			Jobber	Order No.	Incl.
4-piece Kit			\$58.99	GP-500A-G	▼
Guide ID /mm	Driver OD	Pilot			
.312" / 7.92	.422" / 10.7	.305" / 7.75	\$18.99	GP-431-G	x
.312" / 7.92	.487" / 12.4	.302" / 7.67	18.99	GP-531-G	x
.343" / 8.71	.487" / 12.4	.336" / 8.53	18.99	GP-534-G	x
.372" / 9.47	.487" / 12.4	.367" / 9.32	18.99	GP-537-G	x
.437" / 11.10	.611" / 15.5	.428" / 10.87	18.99	GP-743-G	
Metric Sizes			Jobber	Order No.	Incl.
6-piece Kit			\$79.99	GP-600M-G	▼
Guide ID /in.	Driver OD	Pilot			
6.6mm / .260"	11.7 / .462"	6.22 / .245"	\$18.99	GP-6.6MM-G	x
7mm / .275"	10.7 / .422"	6.78 / .267"	18.99	GP-7MM-G	x
8mm / .315"	12.3 / .486"	7.77 / .306"	18.99	GP-8MM-G	x
9mm / .353"	12.3 / .485"	8.84 / .348"	18.99	GP-9MM-G	x
10mm / .393"	15.5 / .611"	9.80 / .386"	18.99	GP-10MM-G	x
11mm / .433"	15.5 / .611"	10.82 / .426"	18.99	GP-11MM-G	x



## Minnesota Fast Freeze instantly chills seats and guides to -50°F / -45.5°C

- Creates interference fit with heated aluminum heads • Finish seat and guide work faster than ever • Aerosol\*
- Use on tight bushings, pins, shafts, etc.
- Order No. **MFF-8** Jobber \$29.99

Buy 6 or more cans MFF-8 and save 10% off jobber

\*Hazardous Goods Fees Apply When Shipped by Air



## Extra-Long Valve Guide Drivers

- For use with overhead cam heads
- 1° negative angle to prevent guide mushrooming • Pilots are slightly smaller than guide ID • 7.5" long

Guide ID /in	Driver OD	Pilot	Jobber	Order No.
4.0mm / .157"	9.0 / .355"	3.80 / .150"	\$22.99	PHL-2240-G
4.5mm / .177"	9.0 / .355"	4.30 / .170"	22.99	PHL-2245-G
5.0mm / .196"	9.0 / .355"	4.75 / .187"	22.99	PHL-2250-G
5.5mm / .217"	10.5 / .412"	5.21 / .205"	22.99	PHL-2255-G
6.0mm / .230"	9.1 / .358"	5.72 / .225"	22.99	PHL-2258-G
6.0mm / .236"	10.5 / .412"	5.72 / .225"	22.99	PHL-2260-G
6.6mm / .260"	11.8 / .463"	6.29 / .248"	22.99	PHL-2234-G
7.0mm / .275"	11.0 / .432"	6.60 / .260"	22.99	PHL-2235-G
7.9mm / .313"	10.7 / .423"	7.72 / .304"	22.99	PHL-2228-G
8.0mm / .315"	11.7 / .462"	7.80 / .307"	22.99	PHL-2236-G
8.7mm / .343"	12.4 / .487"	8.56 / .337"	22.99	PHL-2229-G
9.5mm / .375"	12.4 / .487"	9.32 / .367"	22.99	PHL-2231-G

## Air-Powered Valve Guide Drivers for Diesel Engines

- Drive guides in from the shoulder instead of from the top
- Installing drivers have the proper recess to drive guides in for the correct installed height • Remove / install guides faster – no measuring necessary • For most standard pneumatic tools



Application	Installer Major/ Counter Bore ID	Order No.	Remover Shank/Pilot OD	Order No.
Cummins	.752" / .503"	DVG-Ci	.595" / .450"	DVG-CR
Cummins 8.3. 6CT	.552" / —	DVG-8.3	.491" / .304"	DVG-71R
Caterpillar 3116	.515" / .475"	DVG-3116	.491" / .304"	DVG-71R
Caterpillar 3126	.633" / .506"	DVG-3126	.595" / .354"	DVG-3468R
Caterpillar 3306	.660" / —	DVG-3306	.595" / .354"	DVG-3468R
Caterpillar 3406-3408	.709" / —	DVG-3468i	.595" / .354"	DVG-3468R
Caterpillar 3406-3408B	.632" / —	DVG-3468Bi	.595" / .354"	DVG-3468R
Detroit GMC 53	.502" / .421"	DVG-53i	.491" / .246"	DVG-53R
Detroit GMC 71/92	.502" / .435"	DVG-71i	.491" / .304"	DVG-71R
International DT 466	.640" / .440"	DVG-466i	.595" / .354"	DVG-3468R
Mack	.675" / —	DVG-Mi	.620" / .484"	DVG-MR
Mack 4	.689" / .678"	DVG-M4	.595" / .354"	DVG-3468R

Jobber \$29.99

Jobber \$29.99



## Air Hammer

- Prevents guide damage
- Delivers 3500 blows per minute
- Weighs 3 lbs.
- .401" tool opening

Description	Jobber	Order No.
Air Hammer	\$74.99	AH-335
Replacement Retainer Spring	8.99	AH-5RS

## Universal Driver Tool

- Sized to extend Diesel Guide Drivers above
- .401" ID
- Order No. **CL-7333** Jobber \$37.49



CYLINDER HEAD REBUILDING  
CLEANING, ASSEMBLY & SAFETY  
SHORT BLOCK REBUILDING  
CRANKSHAFT/ FLYWHEEL GRINDING  
MISCELLANEOUS TOOLS & SUPPLIES  
BRAKE & TIRE CHANGING TOOLS  
MEASURING TOOLS  
V-TWIN & METRIC HARD PARTS



"We take our job of getting your order to you quickly very seriously. We use several different carriers allowing us to get your products to you when you need them at a price you can afford."

- Becky, Shipping Department, 2 years of service

**American Made**

**Adjustable Powered Valve Guide Driver With Replaceable Pilots**

- Standardize the correct installed height on one guide then repeat it on all others
- Screw-in pilots with 5/16" - 18 threads
- 6 1/2" overall length

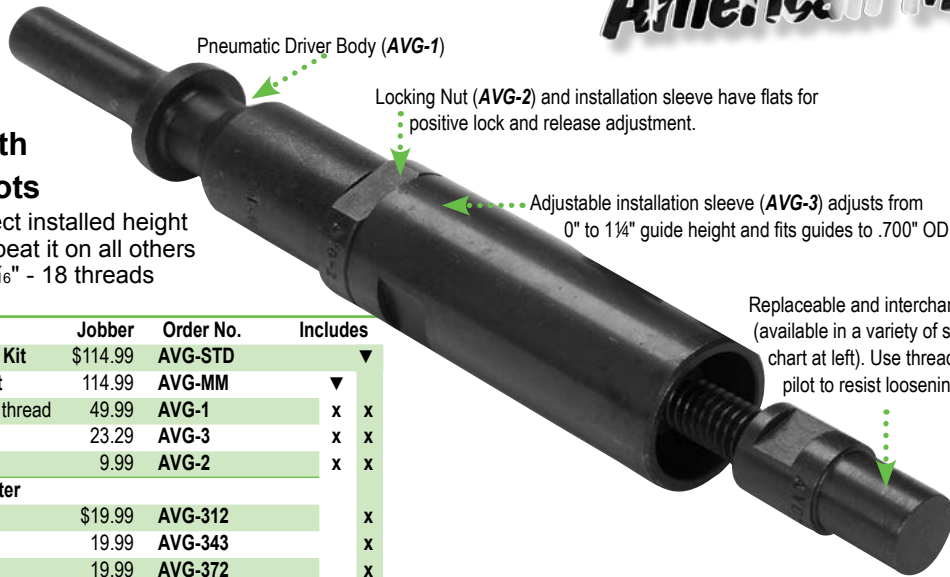

Locking Nut (AVG-2) and installation sleeve have flats for positive lock and release adjustment.

Adjustable installation sleeve (AVG-3) adjusts from 0" to 1 1/4" guide height and fits guides to .700" OD.

Replaceable and interchangeable pilot (available in a variety of sizes, see chart at left). Use thread locker on pilot to resist loosening while in use.

Due to the nature of these pilots, they cannot be warranted against breakage, but are guaranteed to be dimensionally correct.

Description	Jobber	Order No.	Includes	
Standard Valve Guide Driver Kit	\$114.99	AVG-STD	▼	
Metric Valve Guide Driver Kit	114.99	AVG-MM	▼	
Pneumatic Body Only 5/8"-18 thread	49.99	AVG-1	x	x
Installation Sleeve	23.29	AVG-3	x	x
Locking Nut	9.99	AVG-2	x	x
<b>Replaceable Pilots</b>	<b>Diameter</b>			
	.312"	\$19.99	AVG-312	x
	.343"	19.99	AVG-343	x
	.372"	19.99	AVG-372	x
	.437"	19.99	AVG-437	x
	5.0mm	19.99	AVG-5MM	x
	5.5mm	19.99	AVG-55MM	
	6.0mm	19.99	AVG-6MM	x
	6.6mm	19.99	AVG-66MM	
	7.0mm	19.99	AVG-7MM	x
	8.0mm	19.99	AVG-8MM	x
	9.0mm	19.99	AVG-9MM	



**Goodson EXCLUSIVE**

**The more you buy, the more you save!**

Buy 50 - 100 guides, save 10% off jobber.  
Buy 100+ guides, save 20% off jobber (mix & match sizes)



More valve guides on pages 124 and 128

**The more you buy, the more you save!**

Buy 10 or more and save 10% off jobber



**Universal Repair Guides**

- Unfinished ID ready to be reamed with AV&V's exclusive carbide reamers (p. 25) • Manganese bronze

ID	OD	Length	Jobber	Order No.
4.5mm	.620"	2.000"	\$9.49	UVBG-4.5MM
5.0mm	.620"	2.000"	9.49	UVBG-5MM
5.5mm	.620"	2.225"	9.49	UVBG-5.5MM
6.0mm	.620"	2.375"	9.49	UVBG-6MM
7.0mm	.740"	2.700"	8.99	UVBG-7MM
.308"	.740"	2.700"	8.99	UVBG-308
.372"	.740"	2.700"	8.99	UVBG-372

**Cast Iron False Valve Guides**

Universal Applications				
ID	OD	Length	Jobber	Order No.
.312"	.439"	2.281"	\$2.99	CIG-312
.342"	.502"	3.062"	2.99	CIG-342
.372"	.502"	2.750"	2.99	CIG-372
.343"	.564"	2.750"	3.29	OG-343
.373"	.564"	2.750"	3.29	OG-373

24 Valve 7mm Cummins Diesel (.511" seal surface) see tooling, page 24

ID	OD	Length	Jobber	Order No.
Intake .275"	.502"	1.940"	\$3.29	CIG-3021
Exhaust .275"	.502"	2.020"	3.29	CIG-3022
Ford 6.0L (.513" x 659" seal surface) see tooling, page 24				
.275"	.4395"	2.332"	\$2.99	CIG-3055

**Manganese Bronze False Valve Guides**

Universal Applications				
ID	OD	Length	Jobber	Order No.
.250"	.283"	1.250"	\$7.49	BVG-283-125
.311"	.439"	3.062"	5.99	BVG-311
.343"	.502"	2.375"	4.79	BVG-343
.372"	.502"	2.375"	4.79	BVG-372

**Press Fit Lube**

- Ideal for valve guides, piston pins, cylinder sleeves and more
- Eliminates gouging and galling of parts during press fit operation
- Aerosol\*
- Order No. PFL-200 Jobber \$11.99



**Buy 12 or more and SAVE 10% off Jobber**

\*Hazardous Goods Fees Apply When Shipped Air

CYLINDER HEAD REBUILDING  
CLEANING, ASSEMBLY & SAFETY  
SHORT BLOCK REBUILDING  
CRANKSHAFT/ FLYWHEEL GRINDING  
MISCELLANEOUS TOOLS & SUPPLIES  
BRAKE & TIRE CHANGING TOOLS  
MEASURING TOOLS  
V-TWIN & METRIC HARD PARTS



**American Made**

## Bronze-Wall® Bushings

- Spiral inserts rebuild cast-iron guides worn .030"
- Highly durable Phosphor-Bronze
- Thread easily into tapped bore
- Helps guides and stems last longer
- .038" wire for reamed guides

Size	Qty.	Jobber	Order No.
<b>Standard Bushings</b>			
5/16"	50	\$73.49	BW-010B-G
1/2"	50	73.49	BW-020B-G
3/8"	50	73.49	BW-050B-G

**The more you buy, the more you save!**

2-4 boxes of bushings, save 10% off jobber.  
5 or more boxes, save 20% off jobber

Bronze bushings thread easily into tapped bores. Replace guides at any time by simply uncoiling the old ones.



## Bronze-Wall® Broach

- Use with Bronze-Wall® Bushings only
- Pre-sizes the bushing for finish reaming • Use with Bronze Reaming Oil (p. 34)

Size	Jobber	Order No.
5/16"	\$50.29	BW-606-G
1/2"	50.29	BW-626-G
3/4"	50.29	BW-646-G

## Bronze-Wall® Reamers

- Left hand rotation
- Use for final sizing

ID	Size	Order No.
5/16"	.3125"	BW-602-G
1/2"	.3407"	BW-622-3-G
	.3417"	BW-622-2-G
	.3427"	BW-622-1-G
	.3437"	BW-622-G
	.3450"	BW-622A-G
3/8"	.3725"	BW-682-G
	.3740"	BW-642-1-G
	.3750"	BW-642-G

Jobber \$134.99

## Bronze-Wall® 2 Bushings

- Spiral inserts rebuild cast-iron guides worn .030"
- Highly durable Phosphor-Bronze
- Thread easily into tapped bore
- Helps guides and stems last longer
- .035" wire for broached guides
- Easy to install and size using Sizing Ball and Driver instead of Broach and Reamer

Size	Qty.	Jobber	Order No.
<b>Standard Bushings</b>			
5/16"	50	\$73.49	BW2B-312
1/2"	50	73.49	BW2B-343
3/8"	50	73.49	BW2B-375

## Bronze-Wall® 2 Sizing Balls & Driver

- Use with Bronze-Wall® 2 bushings instead of broach and reamers for finish sizing

ID	Size	Jobber	Order No.
5/16"	.312"	\$19.99	CL-5312
1/2"	.343"	19.99	CL-5343
3/8"	.373"	19.99	CL-5373
	.374"	19.99	CL-5374
Sizing Ball Driver		84.99	CL-4444P

More Sizing Balls are listed on page 33

## Use Tooling Below With Both Bronze-Wall® & Bronze-Wall® 2 Bushings

### Bronze-Wall® & Bronze-Wall® 2 Tap Tool

- Three sizes to choose from
- Use to remove existing valve guide from the guide bore
- Use with either Bronze-Wall® or Bronze-Wall® 2 Bushings

ID Size	Jobber	Order No.
5/16"	\$157.49	BW-601-G
1/2"	125.99	BW-621-G
3/8"	164.99	BW-641-G
1/4" Tap Drive Adaptor for 1/2" Drill	45.29	BW-442-G



### Bronze-Wall® & Bronze-Wall® 2 Insert Tool

- Several sizes to choose from
- Use to install Bronze-Wall® bushings into tapped guide bore

Bushing Size	Jobber	Order No.
5/16"	\$84.49	BW-603-G
1/2"	84.49	BW-623-G
3/8"	84.49	BW-643-G

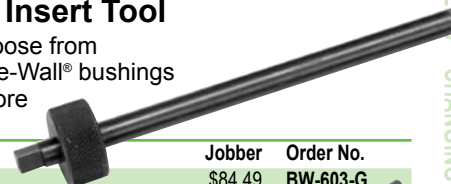

### Bronze-Wall® & Bronze-Wall® 2 Bushing Retainers

- Use with either Bronze-Wall® or Bronze-Wall® 2 Bushings
- Prevents bushings from moving while sizing with reamer or sizing balls

Description	Jobber	Order No.
Bushing Retainer Clamp	\$ 4.79	BW-382-G
Bushing Retainer Clamp Driver	15.29	BW-381-G

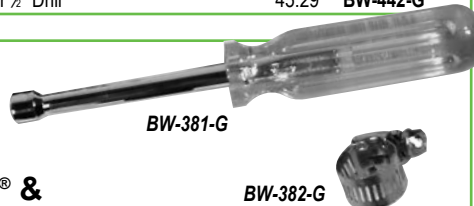

### Bronze-Wall® & Bronze-Wall® 2 Cut-Off Tool

- Use to trim the bushing to final length once it has been finish sized
- Use with both Bronze-Wall® and Bronze-Wall® 2 Bushings

ID Size	Jobber	Order No.
5/16"	\$68.29	BW-471-G
1/2"	81.99	BW-473-G
3/8"	68.29	BW-476-G
<b>Optional Accessories</b>		
Universal Drive Adaptor	\$37.49	CL-7333
Valve Guide Cleaning Brush	3.29	WCB-44



CYLINDER HEAD REBUILDING  
CLEANING, ASSEMBLY & SAFETY  
SHORT BLOCK REBUILDING  
FLYWHEEL GRINDING  
CRANKSHAFT/ MISCELLANEOUS  
TOOLS & SUPPLIES  
BRAKE & TIRE CHANGING TOOLS  
MEASURING TOOLS  
V-TWIN & METRIC HARD PARTS



"Did you know that Goodson still ships orders COD? If you prefer not to use a credit card or set up and open account, you can still order from Goodson. Ask us about COD."

- Pam, Accounting/Purchasing Department, 14 years of service

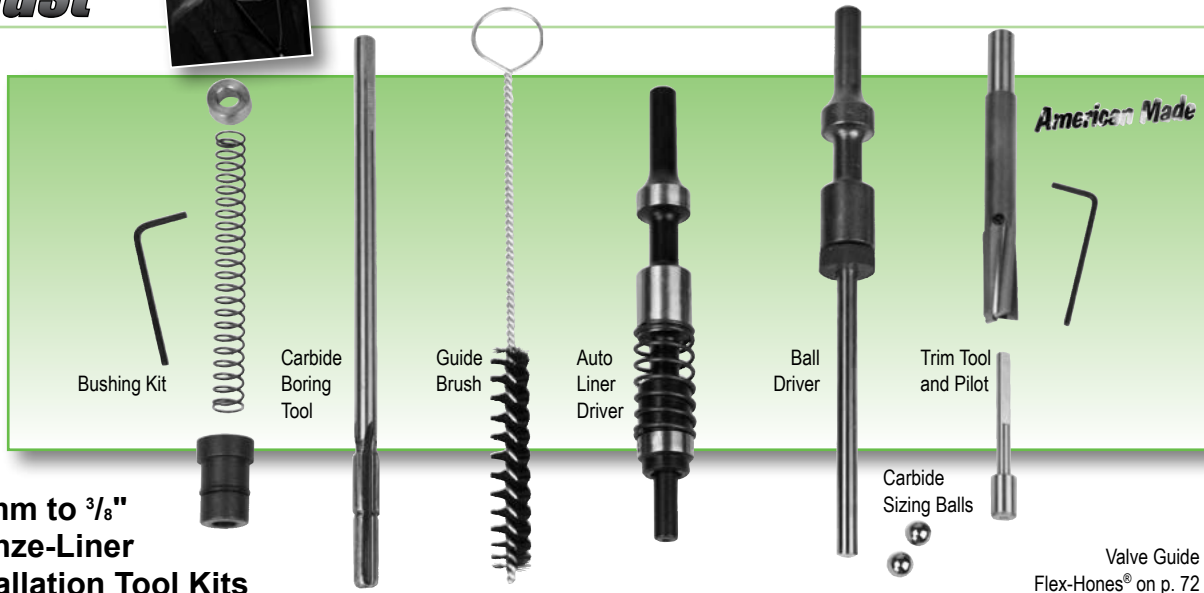

### 5.0mm to 3/8" Bronze-Liner Installation Tool Kits

Phosphor-Bronze is an ideal valve guide material – it's more durable than cast iron, conducts heat away faster and retains lubrication better to reduce wear. Install rugged, thin-wall (.030") Bronze-Liners in cast iron or aluminum heads to repair guides and deliver performance better than new! Plus, Bronze-Liners install quickly with simple tools. If a Bronze-Liner ever wears out, you can quickly and easily replace it with a new one to restore performance. **Removal Tools, page 33.**

Valve Guide  
Flex-Hones® on p. 72

Kits include ▼	5.0mm Guides*		5.5mm Guides*		6.0mm Guides		7.0mm Guides	
Master Tool Kits	\$549.99	CL-5MM	\$499.99	CL-5.5MM	\$419.99	CL-6MM	\$419.99	CL-7MM
Carbide Boring Tool	169.99	CL-2028C	169.99	CL-2026C	127.79	CL-2024C	127.79	CL-2007C
Bushing Kit	54.99	CL-2004	42.99	CL-2002	42.99	CL-2003	42.99	CL-2001
Ball Driver	84.99	CL-4454P	84.99	CL-4452P	84.99	CL-4452P	84.99	CL-4446P
Carbide Sizing Balls	19.99	.1965" CL-51965	19.99	.2175" CL-52175	19.99	.2370" CL-5237	19.99	.2770" CL-5277
	19.99	.1970" CL-5197	19.99	.2180" CL-5218	19.99	.2380" CL-5238	19.99	.2780" CL-5278
Auto-Driver	119.99	CL-3610	119.99	CL-3600	119.99	CL-3600	119.99	CL-3507
Trim Tool	69.79	CL-5602	69.79	CL-5602	69.79	CL-5602	69.79	CL-5600
Trim Tool Pilot	25.99	CL-5636	25.99	CL-5634	25.99	CL-5634	25.99	CL-5626
Guide Brush	6.79	GVP-9N	6.79	GVP-10N	6.79	GVP-10N	3.29	WCB-44

\* 5.0mm and 5.5mm guides require our tooling, see page 33 for tech tip

### Kits Require Seat Centering Cones - See Chart Below

Kits include ▼	5/16" Guides		8.0mm Guides		11/32" Guides		3/8" Guides	
Master Tool Kits	\$399.99	CL-312	\$419.99	CL-8MM	\$399.99	CL-343	\$399.99	CL-375
Carbide Boring Tool	127.79	CL-2005C	127.79	CL-2008C	127.79	CL-2012C	127.79	CL-2014C
Bushing Kit	42.99	CL-2000	42.99	CL-2000	42.99	CL-2000	42.99	CL-2000
Ball Driver	84.99	CL-4444P	84.99	CL-4444P	84.99	CL-4444P	84.99	CL-4444P
Carbide Sizing Balls	19.99	.3125" CL-53125	19.99	.3160" CL-5316	19.99	.3440" CL-5344	19.99	.3750" CL-5375
	19.99	.3130" CL-5313	19.99	.3170" CL-5317	19.99	.3445" CL-53445	19.99	.3760" CL-5376
Auto-Driver	119.99	CL-3500	119.99	CL-3500	119.99	CL-3504	119.99	CL-3506
Trim Tool	69.79	CL-5600	69.79	CL-5600	69.79	CL-5600	69.79	CL-5600
Trim Tool Pilot	25.99	CL-5620	25.99	CL-5620	25.99	CL-5622	25.99	CL-5624
Guide Brush	3.29	WCB-44	3.29	WCB-44	3.29	WCB-44	3.29	WCB-44



### 60° Seat Centering Cones

- Center firmly in the valve seat
- Cones feature a .625" ID
- Steel construction
- Use the Seat Centering Cones with the Master Tool Kits (above) for proper alignment of the reamer and guide bore

Description	Jobber	Order No.
7 pc. Kit	\$199.99	CL-6500
<b>Nominal Range</b>		
1"	0.970"-0.730"	\$37.99 CL-6310
1 1/4"	1.230"-0.740"	37.99 CL-6308
1 1/2"	1.475"-0.805"	37.99 CL-6306
1 3/4"	1.730"-0.860"	37.99 CL-6304
2"	1.950"-0.875"	37.99 CL-6302
2 1/4"	2.230"-1.000"	37.99 CL-6300
2 1/2"	2.550"-1.875"	37.99 CL-6312

tech tips  
from the techxperts™



The centering cone must fit the valve seat properly so using the correct size is essential. This is NOT a one-size-fits-all tool. If you have a cone that is too small for the seat it could slip through the opening. If you have one that's too large, the side of the combustion chamber could interfere or you won't have enough of the cone in the seat area for it to be stable and centered.

CYLINDER HEAD REBUILDING  
CLEANING, ASSEMBLY & SAFETY  
SHORT BLOCK REBUILDING  
CRANKSHAFT/ FLYWHEEL GRINDING  
MISCELLANEOUS TOOLS & SUPPLIES  
BRAKE & TIRE CHANGING TOOLS  
MEASURING TOOLS  
V-TWIN & METRIC HARD PARTS

# Bronze-Liners & Tooling

Buy 3 or more sizing balls (any combination) and save 10% off jobber



## Carbide Sizing Balls

- Finished to .00008" roundness
- Within the 90 Rockwell range
- The finished ID of the Bronze-Liner will be .001" smaller than the ball used



Size	Order No.	Size	Order No.
5.0mm .1960"	CL-5196	8.0mm .3150"	CL-5315
.1965"	CL-51965	.3160"	CL-5316
.1970"	CL-5197	.3170"	CL-5317
5.5mm .2165"	CL-52165	11/32" .3430"	CL-5343
.2175"	CL-52175	.3435"	CL-53435
.2180"	CL-5218	.3440"	CL-5344
6.0mm .2360"	CL-5236	.3445"	CL-53445
.2370"	CL-5237	.3450"	CL-5345
.2380"	CL-5238	.3460"	CL-5346
7.0mm .2760"	CL-5276	3/8" .3730"	CL-5373
.2770"	CL-5277	.3740"	CL-5374
.2780"	CL-5278	.3745"	CL-53745
5/16" .3120"	CL-5312	.3750"	CL-5375
.3125"	CL-53125	.3755"	CL-53755
.3130"	CL-5313	.3760"	CL-5376
.3140"	CL-5314		

Jobber \$19.99

Phosphor-Bronze liners outlast original guides and are easy to replace

Stripe helps you quickly identify the round nose end  
Rounded nose design makes installation fast and easy

## Thin-Wall .030" Bronze-Liners

- Outlast original guides
- Cross-hatch promotes oil retention
- Rounded nose design makes installation quick and easy
- Stripe helps you identify rounded end
- Phosphor-bronze

**tech tips**  
from the techxperts™

NOTE: 5.0 & 5.5mm Guides do NOT interchange with competitors' guides. You MUST use our tooling with these guides.

Guide Size	Liner Size OD	Length	Box of 16		Box of 100	
			Jobber	Order No.	Jobber	Order No.
5.0mm	+ .030"	2.00"	\$19.99	CL-500	\$74.99	CL-500A
5.5mm	+ .030"	2.50"	19.99	CL-550	74.99	CL-550A
6.0mm	+ .030"	2.50"	19.99	CL-600	74.99	CL-600A
7.0mm	+ .030"	2.50"	19.99	CL-700	74.99	CL-700A
.312"	+ .030"	2.50"	19.99	CL-1220	74.99	CL-1220A
8.0mm	+ .030"	2.50"	19.99	CL-1420	74.99	CL-1420A
.343"	+ .030"	3.00"	19.99	CL-1640	74.99	CL-1640A
9.0mm	+ .030"	2.50"	19.99	CL-1690	74.99	CL-1690A
.375"	+ .030"	3.00"	19.99	CL-1830	74.99	CL-1830A
Oversize Bronze Liners						
.343" +.002"	+ .032"	3.00"	\$19.99	CL-1640-2	\$83.99	CL-1640-2A
.375" +.002"	+ .032"	3.00"	19.99	CL-1820-2	83.99	CL-1820-2A



## Removal Tool

Remove bronze liners without damaging the bore

Description	Jobber	Order No.
5.0mm	\$57.99	CL-7356
5.5mm	57.99	CL-7354
6.0mm	57.99	CL-7352
7.0mm	57.99	CL-7344
5/16"	57.99	CL-7310
8.0mm	57.99	CL-7320
11/32"	57.99	CL-7330
3/8"	57.99	CL-7340

## Universal Driver Tool

- Fits all removal tools at left and is designed to work with your air hammer
- .401" ID
- Order No. **CL-7333** Jobber \$37.49



## Chamfer Tool & T-Wrench

Use these optional accessories to remove any burrs that may be created when trimming the liner to length

Description	Jobber	Order No.
Chamfer Tool	\$25.99	CL-5800
T-Wrench	25.99	CL-5870

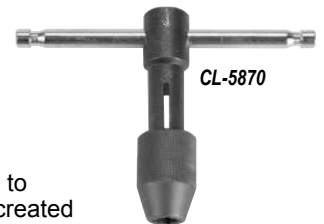

CL-5870



CL-5800

**Mitutoyo**

## Small Hole Gauge Set

- See if rebuilding or replacing is needed by checking actual guide wear
- Check guide bosses for proper interference fit during replacement
- Check and maintain correct stem-to-guide ID clearance
- 4-piece set has combined range of .125" to .500"
- With storage pouch
- Order No. **SHG-5** Jobber \$134.99



**Mitutoyo**

## Split Ball Bore Gauge

- Dial gauge with large contact area
- Measures quickly & accurately to .0001" (.0025mm)
- Works in threaded or knurled guide IDs
- Range: .280"-.400"
- Easy to change contacts
- Includes molded plastic storage case
- Order No. **MVG-34** Jobber \$599.99



CYLINDER HEAD REBUILDING  
CLEANING, ASSEMBLY & SAFETY  
SHORT BLOCK REBUILDING  
CRANKSHAFT/ FLYWHEEL GRINDING  
MISCELLANEOUS TOOLS & SUPPLIES  
BRAKE & TIRE CHANGING TOOLS  
MEASURING TOOLS  
V-TWIN & METRIC HARD PARTS



"We want every aspect of your transaction to be trouble-free. That's why we strive to keep everything as simple for you as possible. We're always looking for new ways to serve you better and we welcome your ideas for how to do that."

- Renee, Accounting Department, 24 years of service

CYLINDER HEAD REBUILDING  
CLEANING, ASSEMBLY & SAFETY  
SHORT BLOCK REBUILDING  
CRANKSHAFT/ FLYWHEEL GRINDING  
MISCELLANEOUS TOOLS & SUPPLIES  
BRAKE & TIRE CHANGING TOOLS  
MEASURING TOOLS  
V-TWIN & METRIC HARD PARTS

## Knurling Arbors

- Piloted for positive centering
- Use by hand or with electric drill & speed reducer
- **Not for use on chilled, hardened or bronze guides**

Inch	mm	Jobber	Order No.
.236"	6.00	\$94.99	<b>WKA-6MM-G</b>
.275"	7.00	94.99	<b>WKA-7MM-G</b>
.312"	7.92	94.99	<b>WKA-312-G</b>
.343"	8.71	94.99	<b>WKA-343-G</b>
.375"	9.53	94.99	<b>WKA-375-G</b>
1 Quart Knurlube (946.6mL)		14.79	<b>WLB-47-G</b>



Use with Knurlube

**NOTE: We don't stock knurling arbors smaller than 6mm because smaller guides are chilled and these arbors may fail.**



## Bronze Reaming Oil

- Prevents build-up
- Extends reamer life
- Improves valve guide finish

Size	Jobber	Order No.
1 Pint / 473.2mL	\$ 9.99	<b>BW-303-G</b>
1 Quart / 946.4mL	15.99	<b>BW-303A-G</b>
1 Gallon / 1.893L	35.99	<b>BW-305-G</b>



## Knurlube

- High pressure lube
- Prevents tool damage
- Extends knurler life by reducing friction and arbor wear

Size	Jobber	Order No.
1/2 Pint / 236.6mL	\$10.49	<b>WLB-46-G</b>
1 Quart / 946.4mL	14.79	<b>WLB-47-G</b>



## Carbide or High Speed Steel Valve Guide Top Cutters

- Matches Seat & Guide machine pilots

Description	Shank	Jobber	Order No.
<b>Cutters</b> 1/16" High-Speed Steel	.500"	\$ 57.99	<b>GFH-100</b>
1/16" Carbide	.500"	149.99	<b>GFC-200</b>
1/8" High-Speed Steel	.486"	99.99	<b>GFH-300</b>
3/16" (.1875")	.312" / 7.93mm	14.99	<b>GFP-312</b>
<b>Shank Pilots</b> .343" / 8.73mm		14.99	<b>GFP-343</b>
.375" / 9.53mm		14.99	<b>GFP-375</b>
.437" / 11.11mm		14.99	<b>GFP-437</b>
.500" / 12.70mm		14.99	<b>GFP-500</b>

3/16" dia. shank

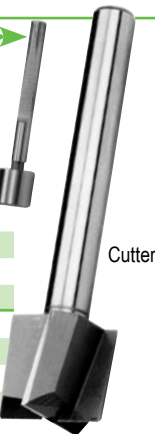

Cutter

## 1" Diameter Carbide Top Cutter / Spot Facer

- Long-life, quick-cutting carbide blades
- Shorten or face cast-iron valve guides and stud bosses up to 1" / 25.4mm diameter
- Universal drive shank fits all types of power chucks 3/8" or larger

Description	Jobber	Order No.
<b>Cutter Body</b>	\$109.99	<b>G-1270</b>
<b>Pilot</b> .312" / 7.93mm	15.79	<b>G-1270A</b>
.343" / 8.73mm	15.79	<b>G-1270B</b>
.375" / 9.53mm	15.79	<b>G-1270C</b>
.437" / 11.11mm	15.79	<b>G-1270D</b>

Pilot Installs Here

Cutter Body  
3/8" Shank



3/8" Shank

## Electric Drill Drive Adaptors For Knurling Arbors and/or Reamers

Use **WSR-41-3-G** (1/4" sq.) or **WSR-41-4-G** (3/16" sq.) with **WSR-41-7-G** (3/8" drill adaptor). Clamp 3/8" drive in drill to drive reamers directly.

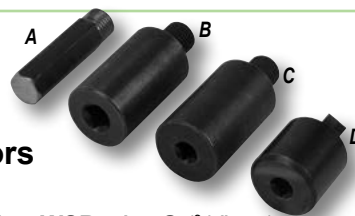

Description	Jobber	Order No.
<b>A</b> Drill Adaptor for 3/8" drill	\$ 7.99	<b>WSR-41-7-G</b>
<b>B</b> 1/4" Adaptor for arbors/reamers larger than .281"	10.99	<b>WSR-41-3-G</b>
<b>C</b> 3/16" Adaptor for arbors/reamers .281" or smaller	14.99	<b>WSR-41-4-G</b>
<b>D</b> Slip on Adaptor (converts WSR-41-3-G to .1875")	19.99	<b>WSR-41-5-G</b>

## Valve Guide OD Knurling Tool

- Enlarge guides to fit bore
- Ideal for rare metric sizes and aluminum heads with damaged guide bores
- Works on most materials, **except** chilled or hardened guides

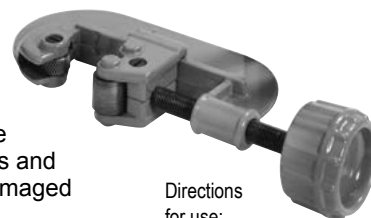

Directions for use:  
Hold guide firmly

in Vise, Drill Press or Seat & Guide machine; tighten the knurler and turn it around the guide by hand. Increase OD up to .002".

## Valve Guide OD Machining Tool Does 3 Jobs at Once!

- Face the guide top to the correct size
- Sizes the guide OD for press-on seals
- Chamfers the top to prevent seal damage
- Cutters & pilots are interchangeable and chuck into any portable drill, drill press or seat & guide machine



Individual Cutters	
Guide OD	Order No.
.415" 10.5	<b>VSC-415</b>
.428" 10.8	<b>VSC-428</b>
.475" 12.1	<b>VSC-475</b>
.495" 12.6	<b>VSC-495</b>
.500" 12.7	<b>VSC-500</b>
.530" 13.5	<b>VSC-530</b>
.562" 14.3	<b>VSC-562</b>
.625" 15.9	<b>VSC-625</b>
Jobber \$71.99	

Pilots	
Guide ID	Order No.
9/32" 7.0	<b>VP-7MM</b>
5/16" 7.9	<b>VP-312</b>
11/32" 8.7	<b>VP-343</b>
3/8" 9.5	<b>VP-375</b>
Jobber \$27.99	

Cutter and Pilot Assemblies			
Guide OD	Pilot Size	Order No.	
.415" 10.5	5/16" 7.9	<b>VSC-415312</b>	
.428" 10.9	5/16" 7.9	<b>VSC-428312</b>	
.475" 12.1	5/16" 7.9	<b>VSC-475312</b>	
.500" 12.7	5/16" 7.9	<b>VSC-500312</b>	
.500" 12.7	11/32" 8.7	<b>VSC-500343</b>	
.500" 12.7	3/8" 9.5	<b>VSC-500375</b>	
.530" 13.5	5/16" 7.9	<b>VSC-530312</b>	
.530" 13.5	11/32" 8.7	<b>VSC-530343</b>	
.530" 13.5	3/8" 9.5	<b>VSC-530375</b>	
.562" 14.3	11/32" 8.7	<b>VSC-562343</b>	
.562" 14.3	3/8" 9.5	<b>VSC-562375</b>	
.625" 15.9	3/8" 9.5	<b>VSC-625375</b>	
Jobber \$94.99			

# Valve Stem Oil Seals

## Valve Seal Puller

- .810" tool dia.
- Fits Multi-Valve Engines
- Lifts from the bottom of the seal
- Works within the confines of lifter bucket bores
- Fingers grip seal for fast, easy removal
- Works on most domestic and import vehicles

**new design**

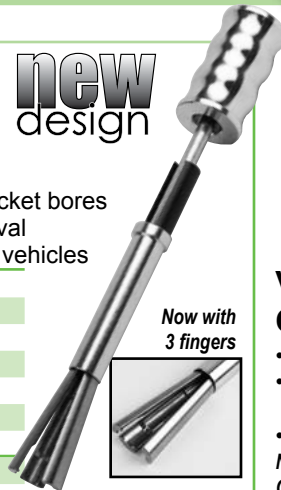

Now with 3 fingers

Description	Jobber	Order No.
Valve Seal Puller	\$199.99	VSP-323
Replacement Shaft	34.99	VSP-323-4
Replacement O-Ring	3.99	VSP-323-5
Replacement Jaw Set	77.29	VSP-323-3
Replacement Jaw Sleeve	41.99	VSP-323-1
Black Split Sleeve	24.99	VSP-323-2

Parts are interchangeable with VSP-320



## Valve Stem Seal Puller

- Plier handles rotate to any position above the head while the jaw assembly goes into the spring cavity
- Can be used straight or at any angle up to 90°
- Jaw tip includes thin ledge for "hooking" underneath stubborn valve stem seals
- 4 vertical raised ridges on inner jaw diameter help grip the outside diameter of the seal
- Order No. **VSP-629** Jobber \$49.99

## Universal Seal Pliers

- Works on OHC and in-line engines with recessed springs
- Long, serrated jaws reach into confined areas and grip seals firmly
- Heat-treated steel with easy-grip handles
- Order No. **VSP-823** Jobber \$49.99



## Aluminum Seal Drivers

- A must-have tool for installing valve seals

Seal Size	Order No.
6.0mm	VSD-6MM
7.0mm	VSD-7MM
.312"	VSD-312
.343"	VSD-343
.375"	VSD-375

Jobber \$23.99



## Valve Seal Drivers

- Color coded for easy size identification

Color	Size	Order No.
Red	.420"	VSD-R
Black	.530"/.562"	VSD-B
White	.625"	VSD-W

Jobber \$6.99



2 Ring Rubber



PTFE PC Seals



PTFE & Rubber

Seals enlarged to show detail

Buy 3 or more boxes of seals (mix & match) and take an extra 15% off jobber



## Valve Stem Oil Seals

- Better oil regulation than umbrella-type
- Seals mount firmly on guide & wipe valve stem clean of excess oil
- Sized precisely for proper lubrication
- 32 per box (VVS-495 is 16 per box)

NOTE: Seals marked with \* are high-temperature exhaust seals • Valve Seal Cutters on page 34

2-Ring Rubber				
Guide OD	Stem OD	Cutter & Pilot Assembly	Jobber	Order No.
.562"	.341"	(VSC-562343)	\$49.49	3011F*
.562"	.341"	(VSC-562343)	35.79	3011D
.625"	.372"	(VSC-625375)	26.29	3012
High Temperature				
Guide OD	Stem OD	Cutter & Pilot Assembly	Jobber	Order No.
.495"	.341"	(VSC-495343)	\$28.99	VVS-495
.531"	.341"	(VSC-530343)	34.79	3711F*
PTFE (non-stick, fluoropolymer) PC Seals				
Guide OD	Stem OD	Cutter & Pilot Assembly	Jobber	Order No.
.415"	.311"	(VSC-415312)	\$48.29	5910
.500"	.341"	(VSC-500343)	54.79	5611
.500"	.372"	(VSC-500375)	64.99	5612
.531"	.311"	(VSC-530312)	59.99	5710
.531"	.341"	(VSC-530343)	55.79	5711
.531"	.372"	(VSC-530375)	59.99	5712
PTFE (non-stick, fluoropolymer) and Rubber				
Guide OD	Stem OD	Cutter & Pilot Assembly	Jobber	Order No.
.500"	.311"	(VSC-500312)	\$30.49	4610
.500"	.341"	(VSC-500343)	54.49	4611
.500"	.372"	(VSC-500375)	54.49	4612
.531"	.341"	(VSC-530343)	57.79	4711
.562"	.341"	(VSC-562343)	56.49	4811
.625"	.372"	(VSC-625375)	49.79	4012

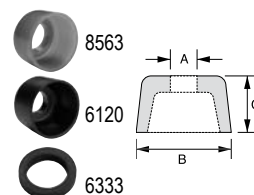

## Universal! Fits all 1 1/32" Valve Stems

- Stem Dia: Seal stem dia. should be smaller than valve stem: Glass/Nylon seals, .003" to .008" smaller. Rubber, at least .025" smaller.
- Outside Dia: Must clear ID of the valve spring and divert oil from the guide.
- Height: Must clear retainer as valve spring is compressed for lock installation.

Type	QTY.	(A)	(B)	(C)	Jobber	Order No.
High Temp: Glass/Nylon Umbrella	32	.335"	.715"	.455"	\$8.49	8563
Low Temp: Rubber Umbrella	32	.310"	.755"	.560"	8.49	6120
Low Temp: Rubber O-Ring	100				6.29	6333

## Cummins Diesel Valve Seals

- For 24 valve, 7mm Cummins Diesel Engines

Application	Stem Size	OD	Qty.	Jobber	Order No.
Intake	7.0mm	.511"	12	\$13.99	CVS-59I
Exhaust	7.0mm	.511"	12	13.99	CVS-59E

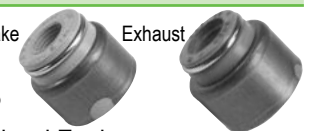

CYLINDER HEAD REBUILDING  
CLEANING, ASSEMBLY & SAFETY  
SHORT BLOCK REBUILDING  
CRANKSHAFT/ FLYWHEEL GRINDING  
MISCELLANEOUS TOOLS & SUPPLIES  
BRAKE & TIRE CHANGING TOOLS  
MEASURING TOOLS  
V-TWIN & METRIC HARD PARTS



**Pneumatic Head:**  
Adjustable to 25° in either direction for canted valves



**Head Support:**  
Table adjusts 45° to the front and 30° to the rear



**Positive Stops:** Adjusts front and rear angles



**Speed Knobs:**  
Allows quick positioning of workpiece



**Foot Pedal:**  
Easy, hands-free operation



**Quick Release Knob:**  
Allows fast positioning to opposite cam bank

**Pneumatic Valve Spring Press**

- Pneumatic valve support holds valve closed as you compress the spring
- Adjustable stainless steel plate won't damage the head
- 28mm Valve Spring Adaptor is standard with unit (other sizes are available, see chart on page 37)
- Ideal for use on heads with recessed springs
- For aluminum and cast iron heads
- Fully assembled
- Replacement Parts Available
- Measures 28" L x 24" W x 26" H
- Order No. **PSB-5000**  
Jobber \$5299.99

**Goodson  
exclusive**

**Slide Hammer:**  
A quick tap loosens keepers for fast removal

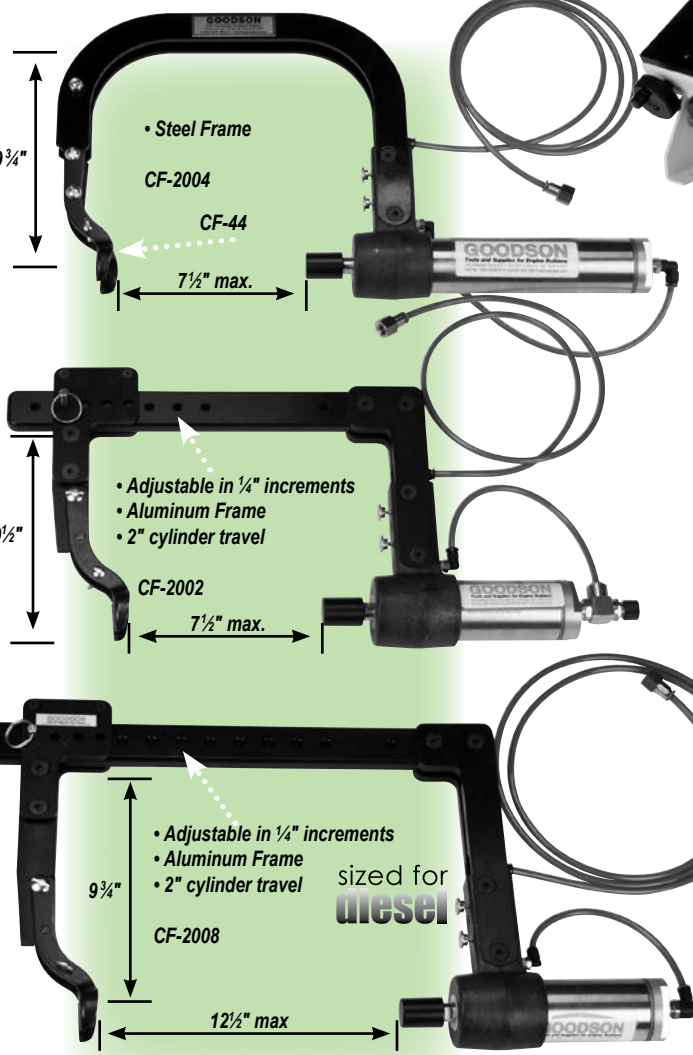
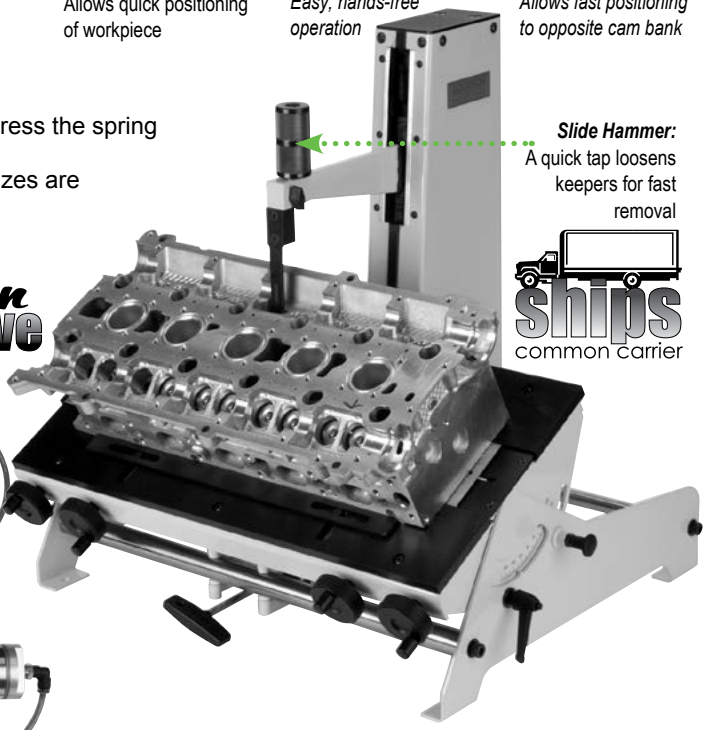

**GOODSON Pneumatic Valve Spring Compressors & Accessories**

- Deliver 325 lbs. of force at 130 PSI • Handle springs from 3/4" to 1 1/4" diameter • Fingertip control
- Replaceable jaws • Full 1 year warranty

Description	Jobber	Order No.
Complete Valve Spring Compressor	\$399.99	<b>CF-2004</b>
Adjustable Automotive Valve Spring Compressor	499.99	<b>CF-2002</b>
Adjustable Diesel Valve Spring Compressor	569.99	<b>CF-2008</b>
<b>Replacement Parts and Accessories</b>		
Replacement Valve Spring Adaptor Jaw	\$13.99	<b>CF-44</b>
Replacement Valve Spring Adaptor Jaw - HD	22.99	<b>CF-44HD</b>
Replacement 1/4" Green Air Line (sold by lin. ft.)	1.99	<b>CF-2001-AL</b>
Replacement Air Control Needle Valve	42.99	<b>CF-2001-NV</b>
Replacement Pneumatic Cartridge	9.99	<b>CF-2003-C</b>
1/4" NPT L-Fitting	5.99	<b>CF-2003-BCE</b>
1/8" NPT L-Fitting	3.99	<b>CF-2003-L</b>

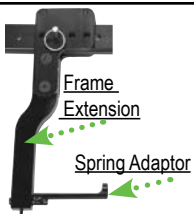

**Convert your CF-2002 Spring Compressor For Use With Multi-Valve OHC Heads**

Description	Jobber	Order No.
Frame Extension	\$62.99	<b>CF-2050</b>
Recessed Spring Adaptors		
26mm OD	55.99	<b>CF-2032</b>

**American Made**

# Valve Spring Compressors

**Goodson  
exclusive**



## Speed Up Valve Spring Replacement With The Manual Valve Spring Bench

- Remove and install valve springs on heads with recessed springs
- 26"L x 22"W x 35"H footprint and weighs 31 lbs.
- Includes 28mm dia. spring adaptor
- Locking collar can be used to stop vertical travel or to keep the spring compressed while assembling keepers
- Frame tilts up to 25° in either direction for canted valves
- Full cylinder head support is adjustable from 0 to 45°
- Integral slide hammer easily releases stuck keepers
- Other spring adaptors also available (see chart below)
- Replacement parts available
- Order No. **CF-500** Jobber \$1799.99

Keeper Tools on p. 38-39



### Lock Collar:

Can be used to stop vertical travel or to hold spring compressed while assembling keepers



### Adjustable Frame:

Adjustable to 25° in either direction for canted valves



### Locking Arm:

Holds the C-frame securely in position at the desired angle



### Head Support:

Adjustable from 0-45° and locks in place



### Dowel Pins:

Keeps the workpiece in place at any head support angle



### Slide Hammer:

A quick tap releases keepers that are stuck in retainers

## Spring Adaptors for Valve Spring Benches

- Fit both manual (**CF-500**) and pneumatic (**PSB-5000**) spring benches
- Solid steel construction with nylon wear insert
- Nylon insert is replaceable

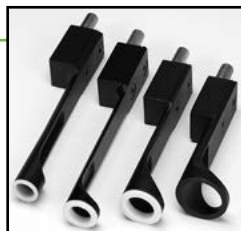

Description	Reach	Jobber	Adaptor	Jobber	Insert
18mm	4½"	\$259.99	CF-518	\$18.99	CF-518-1
23mm	4½"	259.99	CF-501	18.99	CF-501-1
28mm	3½"	259.99	CF-502	18.99	CF-502-1
35mm	2½"	259.99	CF-503		insert not required



## Valve Spring Adaptor Jaws

- Fit frames with double locking screws to secure jaws such as Goodson **CF-2002**, **CF-2004**, **CF-2008** and **CF-140** • Heavy duty jaws are non-adjustable

Description	Jobber	Order No.
Standard Duty 1.000"-1.875" (25.4-47.6mm) Range	\$13.99	CF-44
Heavy Duty (non-adjustable)	22.99	CF-44HD

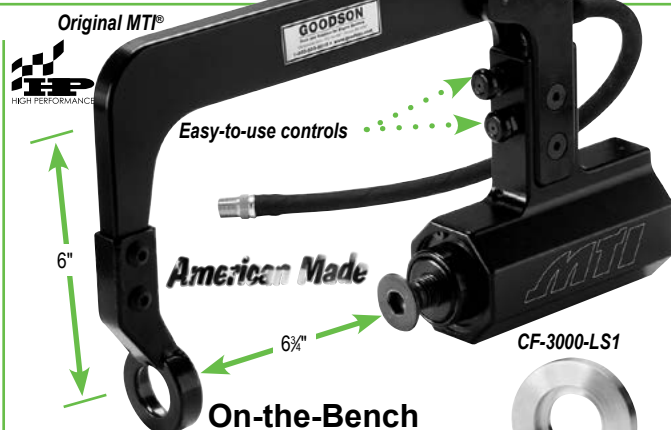

## On-the-Bench Pneumatic Spring Compressor

- Handles springs up to 1500 lbs. at 90 PSI!
- Standard heavy-duty jaw fits springs up to 1.600" diameter
- Optional jaw fits springs to 1.740" diameter
- Features a dual stage cylinder that produces more force each time the control is pressed
- **Guaranteed to a maximum of 90 psi/620.5 kPa pressure**

Description	Jobber	Order No
Hi-Perf. Spring Compressor with 1.600" ID Jaw	\$1299.99	CF-3000B
Replacement Standard Jaw, 1.600" ID	119.99	CF-3002
Adaptor Jaw, 1.740"/44.2mm ID	119.99	CF-3003
LS1 Series Jaw Adaptor	34.99	CF-3000-LS1
Rebuild Seal Kit (includes Intake Button Return Spring)	34.99	CF-3000SK
Replacement Intake Button Return Spring	8.99	CF-3004
Intake Trigger Assembly	49.99	CF-20004A
Exhaust Trigger Assembly	47.99	CF-20004B

CYLINDER HEAD REBUILDING  
CLEANING, ASSEMBLY & SAFETY  
SHORT BLOCK REBUILDING  
CRANKSHAFT/ FLYWHEEL GRINDING  
MISCELLANEOUS TOOLS & SUPPLIES  
BRAKE & TIRE CHANGING TOOLS  
MEASURING TOOLS  
V-TWIN & METRIC HARD PARTS



"You'll always get fast, reliable service from Goodson, even on international orders. We'll do whatever it takes to make sure you get your shop supplies as quickly and easily as possible - anywhere in the world."

- Kim, Goodson Customer Service Manager, 33 yrs. of service

CYLINDER HEAD  
REBUILDING

CLEANING,  
ASSEMBLY & SAFETY

SHORT BLOCK  
REBUILDING

CRANKSHAFT/  
FLYWHEEL GRINDING

MISCELLANEOUS  
TOOLS & SUPPLIES

BRAKE & TIRE  
CHANGING TOOLS

MEASURING  
TOOLS

V-TWIN & METRIC  
HARD PARTS

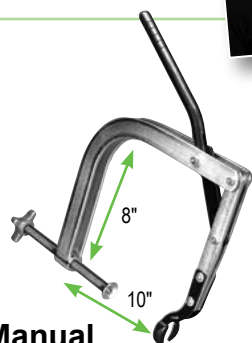

### Manual Valve Spring Compressor

- Weighs only 6 lbs
- High leverage allows for easy, one-hand operation
- Covers a range from 10" high to 8" deep
- Works with most L-head and valve-in-head engines
- Fits truck & tractor engines
- Jaws adjust for small, medium and large springs

Description	Jobber	Order No.
Spring Compressor	\$89.99	<b>CF-140</b>
Replacement Jaw Set	13.99	<b>CF-44</b>
HD Replacement Jaw Set	22.99	<b>CF-44HD</b>



### small engine powersports

### Manual Valve Spring Compressor

- Compress **only** the spring for fast and easy keeper removal
- Fully adjustable steel jaws have maximum opening of 2 1/2" (63.5mm)
- For springs 1/2" (12.7mm) to 1 1/8" (28.6mm) in diameter
- Cadmium finished spring steel construction
- Order No. **CF-131** Jobber \$17.99

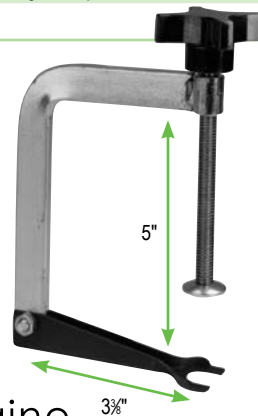

### Manual Valve Spring Compressor For Small Engines

- Steel construction
- 20# max. spring pressure
- Once you lock the compressor in position, your hands are free to work
- Includes 2 jaw sets - small, for springs up to 7/8" (22.2mm) and large, for springs up to 1 1/8" 27.0mm)
- Order No. **CF-600** Jobber \$21.99

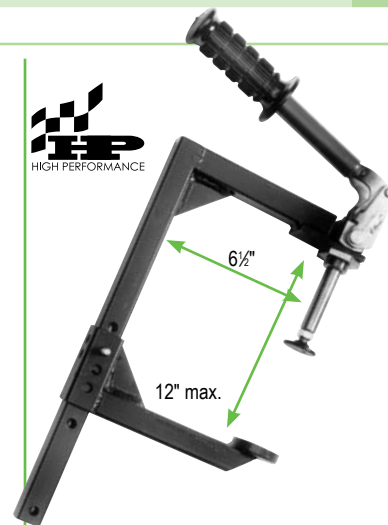

### Manual Valve Spring Compressors

- Handle valve springs from a range of applications
- Welded, gusseted all-steel construction takes plenty of abuse
- Plenty of leverage to compress valve springs
- Order No. **CF-1500** Jobber \$239.99

Back by popular demand!

### Multi-Valve Head Manual Valve Spring Compressor

- Welded, gusseted all-steel construction takes plenty of abuse
- Plenty of leverage to compress valve springs
- Covers a range from 8" high to 5"

Description	Jobber	Order No.
Multi-Valve Spring Compressor	\$113.67	<b>CF-1400</b>
Replacement Adaptor - 3/4" OD	34.99	<b>CF-6</b>

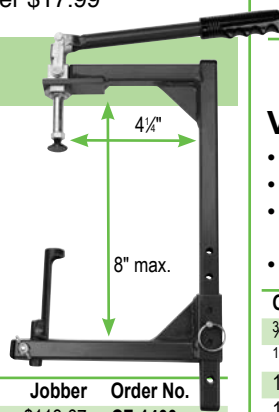

### Valve Spring Compressor Adaptor

- Fit seat and guide machines or drill press
- Puts collet or drill press chuck behind adaptor
- Allows more room to remove or re-install valve keepers and associated components
- Fits 1/2" collet or Jacobs chuck (not included)

OD (mm)	Reach (mm)	Jobber	Order No.
3/4" (19.1)	3 3/4" (95.3)	\$34.99	<b>CF-6</b>
1 1/16" (20.6)	3 3/4" (95.3)	34.99	<b>CF-8</b>
1" (25.4)	3 3/4" (95.3)	39.99	<b>CF-10</b>
1 1/4" (31.7)	3 3/4" (95.3)	42.99	<b>CF-12</b>
1 1/2" (38.1)	3 3/4" (95.3)	42.99	<b>CF-15</b>



### Small OHV Engine Keeper Removal & Installation Tool

- Easy to use - Uses your own body weight as leverage
- Works with 3.5mm to 5.5mm single groove valves only
- Complete set includes a remover with powerful magnet to hold the keepers in place after removal, universal installer and two non-slip valve chamber pads

Description	Jobber	Order No.
Keeper Removal Installation Tool	\$94.99	<b>VKI-35</b>
Keeper Magnet - 6 3/8" holder with .170" dia. Earth magnets	15.99	<b>VKM-17</b>

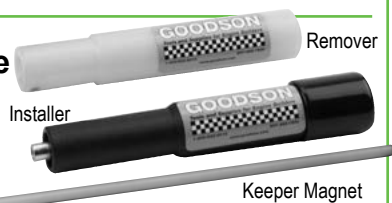

### Adaptors for Deeply Recessed Springs

- Open top design gives easy access to keepers
- Durable, non-marring material
- Fit on Split-Jaw Spring Adaptors such as our **CF-44** (p. 37)



Description	OD	Height	Jobber	Order No.
Small Adaptor	26mm	4" (101.6mm)	\$27.79	<b>CF-32</b>
Medium Adaptor	27mm	3" (76.2mm)	27.79	<b>CF-24-G</b>
Large Adaptor	32mm	3" (76.2mm)	27.79	<b>CF-25-G</b>

Spring sold separately

Max. 2 1/2"



## L-Head Manual Spring Compressor

- Easily removes springs in recessed area of valve in block engines
- Handle turns to open and close the compressor
- Integral jaws accommodate springs up to 1 1/8" OD
- Sized for industrial engines - Continental, Waukesha, etc.
- Use with Flat Head straight stem valves, 1949 & newer
- Order No. **CF-122** Jobber \$19.99

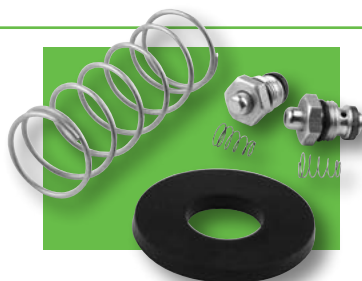

## Pneumatic Valve Spring Compressor Rebuild Kit

- For pneumatic spring compressors with threaded shaft such as Plews, Clark Feather, etc.
- Includes seals, valves, springs and o-rings
- Order No. **CF-700-RK** Jobber \$84.99

CF-21A-G



CF-22C-G



CF-23-G

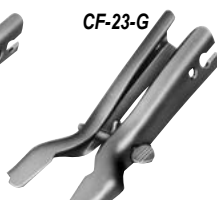

## Standard Valve Spring Adaptors

- For threaded shaft spring compressors
- Thumb screw adjustment
- Single locking screw secures jaw to frame

Adjustment Range	Jobber	Order No.
.875" - 1.875" (22.2-47.6mm)	\$14.99	<b>CF-21A-G</b>
1.00" - 2.000" (25.4-50.8mm)	14.99	<b>CF-22C-G</b>
1.50" - 2.500" (38.1-63.5mm)	15.99	<b>CF-23-G</b>
Replacement Thumb Screw	1.49	<b>CF-700-2-G</b>

## Heavy Duty Valve Spring Adaptors

- Heavy duty jaws are not adjustable



CF-22HD



CF-23HD

Spring Size Range	Jobber	Order No.
1.00" - 2.000" (25.4-50.8mm)	\$27.49	<b>CF-22HD</b>
1.50" - 2.500" (38.1-63.5mm)	27.49	<b>CF-23HD</b>



## V-Twin On-the-Engine Valve Spring Compressor

Replace broken valve springs, install high performance valve springs, remove and replace valve guide seals all without disassembling the bike – just remove the gas tank and get to work. Use on Sportster, Evolution, Twin-Cam and most aftermarket V-Twins. Kit includes valve spring compressor, adaptor for compressing beehive springs, valve seal driver/installer and head pressurizing hose.

Order No. **CF-HDIF**  
Jobber \$159.99



Visit the Goodson Blog for more information on using the On-The-Engine Spring Compressor <http://www.goodson.com/blog/?p=3646>

## Keeper Installation Tools

*Best Keeper Tool on the Market!*

- Spring-loaded plunger
- For single & multi-groove keepers
- Reaches keeper grooves located farther from the valve tip • Ideal for use with **CF-500** (p. 37) and **PSB-5000** (p. 36)



Size	Jobber	Order No.
4mm / .1563"	\$79.99	<b>VKI-4</b>
5mm / .2031"	79.99	<b>VKI-5</b>
6mm / .2344"	79.99	<b>VKI-6</b>
7mm / .2812"	79.99	<b>VKI-7</b>
8mm / .3125"	79.99	<b>VKI-8</b>
Replacement Rubber Sleeve	6.99	<b>VKI-56</b>

CF-842



VKM-17

VK-15

## Keeper Tools

Description	Jobber	Order No.
Keeper Tool	\$ 8.99	<b>CF-842</b>
Keeper Magnet – 6 5/16" holder .170" dia. earth magnet	15.99	<b>VKM-17</b>
Keeper-Keeper – PVC 1/4" holes keep keepers in	15.99	<b>VK-15</b>

CYLINDER HEAD REBUILDING  
CLEANING, ASSEMBLY & SAFETY  
SHORT BLOCK REBUILDING  
FLYWHEEL GRINDING  
CRANKSHAFT/  
MISCELLANEOUS TOOLS & SUPPLIES  
BRAKE & TIRE CHANGING TOOLS  
MEASURING TOOLS  
V-TWIN & METRIC HARD PARTS



"Our staff of ASE-Certified Techxperts® can help you solve problems fast! Call with questions about product applications, machining precision, longer tool life, improving efficiency, cost savings or any other technical topic. We're here to help you!"

- Erik, Tech Support Manager, 16 years of service

CYLINDER HEAD  
REBUILDING

CLEANING,  
ASSEMBLY & SAFETY

SHORT BLOCK  
REBUILDING

CRANKSHAFT/  
FLYWHEEL GRINDING

MISCELLANEOUS  
TOOLS & SUPPLIES

BRAKE & TIRE  
CHANGING TOOLS

MEASURING  
TOOLS

V-TWIN & METRIC  
HARD PARTS

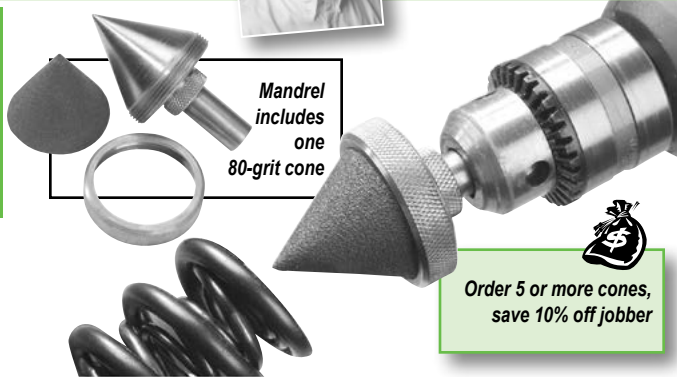

Mandrel includes one 80-grit cone

Order 5 or more cones, save 10% off jobber



### Small Chamfering Cones & Mandrels Make Deburring and Chamfering Easy In Tight Spaces

These mandrels are available in two diameters – 3/4" and 1 1/2" diameters with a 1/2" shank to fit most portable drills. The small diameter fits easily into tight spaces such as Beehive Valve Springs (see page 129) or bolt holes. The mandrel is designed to support a 60° abrasive cone which is held securely by the retaining ring. One 80-grit cone is included with initial purchase.

Description	Jobber	Order No.
3/4" Dia. Mandrel	\$57.79	CC-34
3/4" Dia. Abrasive Cones	80 grit	2.99 CC-35
	120 grit	2.99 CC-36
1 1/2" Dia. Mandrel	\$60.99	CC-60
1 1/2" Dia. Abrasive Cones	80 grit	4.29 CC-61
	120 grit	4.29 CC-62

### Universal Gel Lube

- Sprays on as a liquid and forms into a gel within seconds
- Penetrating formula blends freely with motor oil
- Multiple uses, including cams, lifters, rocker arms, bearings, pistons/wrist pins, cylinders, etc.
- Provides lubrication for engines subjected to prolonged storage before initial start-up
- Aerosol\*
- Order No. **GL-8U** Jobber \$17.99



Buy 6 or more cans and save 10% off jobber



\*Hazardous Goods Fees Will Apply if Shipped by Air

### 8 Piece Valve Train Checking Spring Set

- 1.250" OD
- Spring Steel construction
- Essential for high-performance engine building and engine blueprinting
- Maintain a positive valve train position while checking valve to piston clearance
- Order No. **VTS-8** Jobber \$14.99



3-D Fast Cut™ Adjustable Spring Pad Cutters on page 10

### Valve Spring Seat Cutters

- Resize valve spring seats to maintain spring-to-valve concentricity or use to enlarge seats for over-size dual springs
- Requires special pilot – see chart below

#### Carbide Tipped Cutter Bodies (use VP pilots below)

OD	ID	Jobber	Order No.
1.320"	.630"	\$89.99	<b>VSS-1320</b>
1.350"	.625"	89.99	<b>VSS-1350</b>
1.500"	.625"	89.99	<b>VSS-1500</b>
1.550"	.625"	89.99	<b>VSS-1550</b>
1.625"	.625"	89.99	<b>VSS-1625</b>
1.680"	.750"	89.99	<b>VSS-1680HD</b>
1.750"	.625"	89.99	<b>VSS-1750</b>

#### Hardened & Ground Pilots

Guide ID	Jobber	Order No.
3/32"	7.0	\$27.99 <b>VP-7MM</b>
3/16"	7.9	27.99 <b>VP-312</b>
11/32"	8.7	27.99 <b>VP-343</b>
3/8"	9.5	27.99 <b>VP-375</b>



### tech tips

from the Techxperts™  
You must use these pilots with the VSS and VSC cutters. The flat sides are necessary for a proper fit.

Buy the kit and SAVE!

### Dial Indicated Valve Stem Height Gauges

- 5 sizes to choose from
- Small diameter extended measuring body allows extra height for dial indicator clearance
- Use with our large-faced Dial Indicator to check valve tip height



Description	Jobber	Order No.	Incl.
Valve Stem Height Gauge Kit w/Stand	\$199.99	<b>VSH-KIT</b>	▼
Valve Stem Height Gauge Kit	119.99	<b>VSH-200</b>	▼
Dial Indicator (2" travel, .001" graduations)	59.99	<b>MDI-2</b>	x x
Dial Indicator (1" travel, .001" graduations)	27.99	<b>EDI-1</b>	
Measuring Bodies	OD ID OAL		
	.750" .625" 3.830"	\$39.99 <b>VSH-205</b>	x
	.900" .770" 2.840"	39.99 <b>VSH-203</b>	x
	.900" .770" 3.840"	39.99 <b>VSH-204</b>	x
	1.060" .812" 2.840"	39.99 <b>VSH-201</b>	x x
	1.250" 1.090" 3.300"	39.99 <b>VSH-202</b>	x x
Tool Stand	44.99	<b>TS-5</b>	x
1" Checking Standard	9.99	<b>MCS-1</b>	

More dial indicators on page 119



Easy-to-use Travel Stop with adjustable set screws lets you set an exact position, allowing repeated testing at a desired height. Two set screws allow you to adjust for installed spring height and max lift (near coil bind).

Arbor style handle makes compressing springs fast and easy

Integral digital travel readout

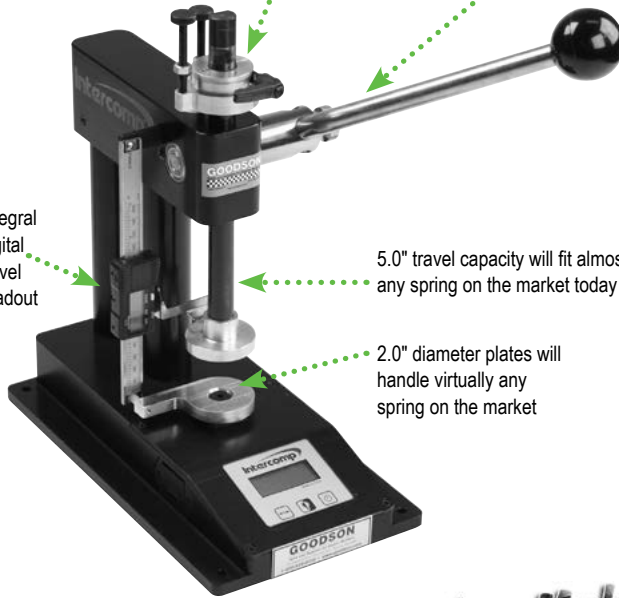

5.0" travel capacity will fit almost any spring on the market today

2.0" diameter plates will handle virtually any spring on the market

**American Made**

**Intercomp®**  
**Digital Arbor Valve Spring Tester**

- 1,500 lb / 680.4 kg load cell in 1 lb. increments
- Force units switchable from pounds to kilograms
- Billet 6061 T-6 Aluminum construction
- Digital travel readout at .001"/inch or .01mm
- 5" travel capacity • 2.0" diameter spring pads
- Easy to read backlit screen
- Operates on 9V battery (included)
- Adjustable stop to repeatedly check springs at the same heights
- Order No. **VST-2000** Jobber \$1399.99



For routine calibration of spring testers, return tester to Goodson. Call for details, 1-800-533-8010.

**Calibrated Spring**

- Check Spring Tester Accuracy
- Highest-quality spring steel
- Calibrated to show pressure at a specified compressed height (includes calibration certificate)
- Rating: Min. = 100 lbs.  
Max. = 285 lbs.
- Order No. **VST-95** Jobber \$57.99



Vertical scale shows inches on one side and millimeters on the other

Pressure Gauge reads in both pounds and kilograms



**Analog Valve Spring Tester** **American Made**

- 5" diameter Ashcroft analog pressure gauge with 600 lb. (272kG) capacity in 10 lb. (4.54kG) increments
- Platform handles springs up to 2" diameter x 4 1/2" OAL
- Vertical height adjustments in 1/4" increments
- Adjustable pressing anvil for fine-tuning open and closed pressures for height measurement
- T-Handle conforms to the operator's grip for firm control
- Calibrated, sealed hydraulic load cell
- Over-center cam action holds spring at the desired height
- Rubber protective boot keeps the mechanism debris-free
- Base features four 3/16" mounting holes to bolt it to the bench
- Order No. **VST-60G** Jobber \$879.99

**TECHNICAL SPECS:**  
**UNIT WEIGHT:** 19 1/2 lbs.  
**FOOTPRINT:** 8 1/2" sq.  
**HEIGHT:** 28" with handle fully extended

**tech tips** **What is coil bind and how is it measured?**  
from the techxperts™

Coil bind is the point at which a valve spring is fully compressed so that there is no space between the coils. You do **NOT** want your springs to reach this position when in use since it will cause damage to the camshaft and valve train components. To measure coil bind height, install the retainer in the valve spring and compress the spring until the coils are stacked tightly together. Measure from the bottom of the spring to the bottom of the retainer. This is your coil bind height.

**Height Indicator**

- Measure compressed spring height when testing pressure
- Ideal for high performance and checking identical springs
- For Rimac® and other spring testers
- Height Scale displays inches and metric
- Includes Dial Indicator, and Mounting Kit (additional dial indicators on page 119)
- Order No. **VST-25** Jobber \$67.99

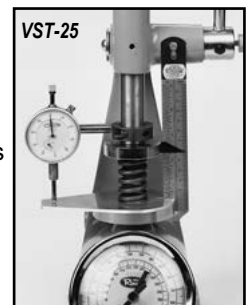

CYLINDER HEAD REBUILDING  
CLEANING, ASSEMBLY & SAFETY  
SHORT BLOCK REBUILDING  
FLYWHEEL GRINDING  
CRANKSHAFT/ FLYWHEEL GRINDING  
MISCELLANEOUS TOOLS & SUPPLIES  
BRAKE & TIRE CHANGING TOOLS  
MEASURING TOOLS  
V-TWIN & METRIC HARD PARTS



"We work hard to earn your business; every day, every order. You can count on Goodson to be your most reliable and friendly source for shop supplies."  
- Richard, Customer Service - 17 years of service

CYLINDER HEAD REBUILDING  
CLEANING, ASSEMBLY & SAFETY  
SHORT BLOCK REBUILDING  
CRANKSHAFT/ FLYWHEEL GRINDING  
MISCELLANEOUS TOOLS & SUPPLIES  
BRAKE & TIRE CHANGING TOOLS  
MEASURING TOOLS  
V-TWIN & METRIC HARD PARTS

### Non-Serrated Valve Spring Booster Shims

- Shims meet or exceed OE specifications
  - Made of prime quality cold rolled steel
  - Support valve springs better
  - Won't compress
  - Maintains pressure and protects head from spring abrasion
  - Non-serrated shims won't damage spring pad area on aluminum heads or cause lateral loads or harmonics
- Special Orders are available. Call 1-800-533-8010 to inquire.



### Magnetic Head Bolt Washer & Valve Spring Shim Removal Tools

Avoid self-inflicted wounds from sharp spring shim removal tools or the ever-popular oil shower from using air pressure to remove head bolt washers. The hollow design of these magnetic removal tools allow easy access over studs or head castings and the powerful earth magnets grab firmly, letting you lift the washer or shim out easily.

Size	50 count High Performance			100 count		
	OD	ID				
1.000"	0.688"			A-101	B-101	C-101
	0.765"			A-104	B-104	
1.100"	0.719"				B-106	
1.218"	0.875"		HIGH PERFORMANCE	A-105	B-105	
1.250"	0.625"	A-107-HP	B-107-HP	C-107-HP	A-107	B-107
	0.812"	A-203-HP	B-203-HP	C-203-HP	A-203	B-203
	0.875"			A-201	B-201	
1.360"	1.000"	A-102-HP	B-102-HP	C-102-HP	A-102	B-102
1.375"	0.765"	A-301-HP	B-301-HP	C-301-HP		B-301
1.437"	0.785"	A-305-HP	B-305-HP	C-305-HP		
1.438"	0.645"	A-306-HP	B-306-HP	C-306-HP		
1.480"	0.703"	A-303-HP	B-303-HP	C-303-HP	A-303	B-303
	0.645"	A-306S-HP	B-306S-HP	C-306S-HP		
1.500"	1.031"	A-103-HP	B-103-HP	C-103-HP	A-103	B-103
	0.643"	A-601-HP	B-601-HP	C-601-HP		
Jobber	\$19.99	\$19.99	\$19.99	\$19.99	\$19.99	\$19.99

Description	Jobber	Order No.	Incl.
Magnetic Remover Set	\$109.99	MWR-SET	▼
Washer Removers	ID	OD	
	0.250"	0.625"	\$31.99 MWR-14 x
	0.500"	0.865"	31.99 MWR-12 x
	0.450"	0.812"	31.99 MWR-716 x
Shim Remover	0.708"	1.355"	34.99 MVR-2 x



No More Guesswork...  
Measure CCs  
Accurately!

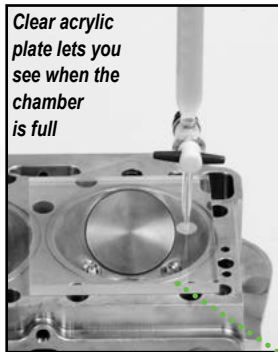

Clear acrylic plate lets you see when the chamber is full



Positive fluid control

100cc Glass Buret allows use with alcohol or solvent

Clamp gives you ability to fully adjust the height of the buret in relation to your cylinder head

### Cylinder Head CC-ing Equipment

- Use glass buret with alcohol or solvent
- Positive on/off fluid control valve
- Clear acrylic plate lets you see when the combustion chamber is full
- Mix Measuring Concentrate with water to make 1 gallon

Description	Jobber	Order No.	Incl.
CC-Measurement Kit	\$169.99	CCB-KIT	▼
100cc Glass Buret	99.99	CCB-100	x
5" x 5" x 3/8" Acrylic Plate	10.99	GCB-3	x
Buret Cleaning Brush - 35/2" OAL	9.99	GCB-BRUSH	x
Buret Stand	17.99	GCB-1	x
Buret Clamp	17.99	GCB-2	x
Funnel	10.49	CCB-FUNNEL	x
Measuring Liquid Concentrate (Gallon Yield)	14.99	GCB-LIQUID	
4" Precision Cylinder Head Level	154.99	LEV-4	
Replacement Vial for 4" level	99.99	VGL-101	
100cc Glass Beaker	39.99	GC-100	
Universal Cylinder Head Holders (pair)	129.99	HH-200	

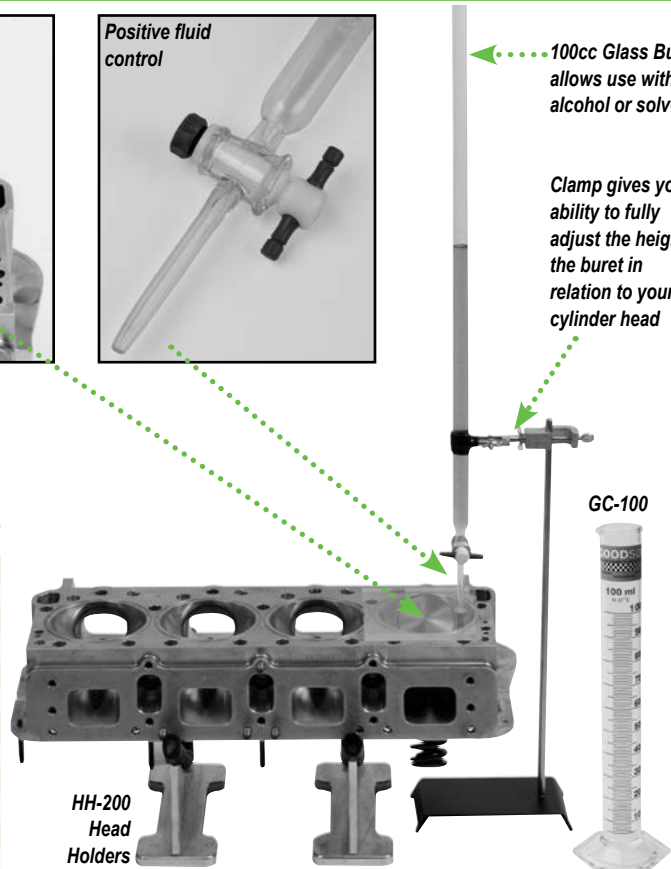

HH-200 Head Holders

GC-100

# Cylinder Head Resurfacing

## tech tips

from the techxperts™  
Confirm level calibration before every use. Scan the code above to see our how-to.



## 2-Way Resurfacing Set-up Level

- Top-quality CNC machined T-6 aluminum frame with hardened & ground tool-steel contact pads
- Level both directions at once
- Includes 6" precision vials (LEV-8-1)
- Weighs just 2 lbs.
- Order No. **LEV-TR**  
Jobber \$399.99

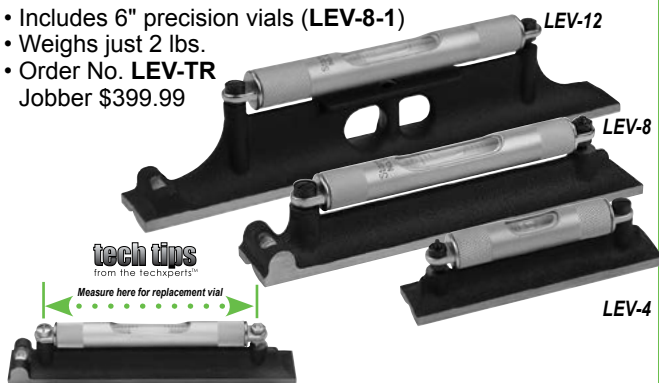

## Precision Levels and Vials

- Graduated vials with satin-chromed, brass protective covers that rotate to close tightly
- Base castings are seasoned, then precision machined and finished on a bearing surface • Replaceable vials
- Adjustable for precise calibration
- 1 division equals .0005" per inch
- Fits pilots from 6mm to .437"



VGL-100  
(pilot sold separately)

Description	Jobber	Order No.	Replacement Vial
4" Valve Guide Level (3" vial)	\$199.99	<b>VGL-100</b>	\$ 99.99 <b>VGL-101</b>
4" Level (3" vial - nominal)	154.99	<b>LEV-4</b>	99.99 <b>VGL-101</b>
8" Level (6" vial - nominal)	229.99	<b>LEV-8</b>	137.99 <b>LEV-8-1</b>
12" Level (8" vial - nominal)	319.99	<b>LEV-12</b>	169.99 <b>LEV-12-1</b>

## Import / Metric Cylinder Head Stud Stretchers

- Save time, don't remove the studs from a head for resurfacing • Put stud stretchers on two studs and leave the rest • Sold in pairs

Length	Thread	Jobber	Order No.
3"	8mm x 1.25	\$53.99	<b>SS-20</b>
3 3/4"	8mm x 1.25	53.99	<b>SS-30</b>
3 3/4"	10mm x 1.25	53.99	<b>SS-40</b>

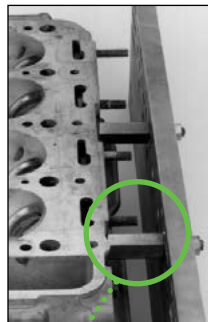

resharpening available

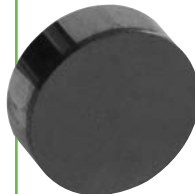

## PCD Inserts for Aluminum

- A must for shops committed to meeting today's strict surface finish requirements
- Fits machines with 3/8" and 1/2" CBN holder
- 1/2" diameter inserts require shim (included)
- Use with Resurfacing Spray (**HPS-16**) for best results (see below)

Size	Jobber	Order No.
3/8" (9.53mm) Diameter	\$179.99	<b>PCDS-375</b>
1/2" (12.7mm) Diameter (shim included)	189.99	<b>PCDS-500</b>
1/2" (12.7mm) Diameter (single sided) Radiac Brand	227.99	<b>2379265</b>
High Performance Resurfacing Spray	11.99	<b>HPS-16*</b>

\* Hazardous goods fees apply when shipped air

resharpening available

## CBN Cutter Inserts For Cast Iron

- Faster and cleaner than segments and wheels

Titanium-Nitride Coated			Goodson		Uncoated Radiac	
Dia.	Thick.	Sided	Jobber	Order No.	Jobber	Order No.
3/8"	1/8"	Double	\$179.99	<b>CBN-375D</b>	—	—
		Single	159.99	<b>CBN-375S</b>	\$184.99	<b>2X5346</b>
		Double	—	—	239.99	<b>2359232</b>
1/2"	3/16"	Single	—	—	324.99	<b>2X5357</b>
		Double	229.99	<b>CBN-500D*</b>	199.99	<b>2X5299</b>
		Single	249.99	<b>CBN-500S</b>	209.99	<b>2359233</b>

### Sharp Uncoated

3/8"	1/8"	Single	\$139.99	<b>CBNS-38</b>	—	—
1/2"	3/16"	Single	167.99	<b>CBNS-12</b>	—	—
1/16"	Thick Carbide Shim*		21.99	<b>CBN-500SHIM</b>	—	—

\*Shim required on DCM machines

resharpening available

Enlarged for clarity



## Super Abrasive For Cast Iron Diesel Heads

- Designed for cast diesel heads with hardened pre-cups • Won't chip
- Fits all overhead surfacers with 1/2" diameter insert capacity
- Will **NOT** work on standard cast heads
- .500" (12.7mm) diameter • .125" (3.2mm) thick
- Order No. **DRD-500** Jobber \$344.99

\*NOTE: A 1/16" thick carbide shim must be used with DRD-500 on DCM machines • Order No. **CBN-500SHIM** Jobber \$21.99

Buy 6 or more cans, save 10% off jobber

Mix or match with High Performance Resurfacer Spray (**HPS-16**), Cutting & Tapping Fluid (**CTF-14**) and Minnesota Fast Freeze (**MFF-8**) to achieve the quantity discount



## High Performance Resurfacing Spray

- Prolongs cutter life
- Enhances surface finish
- Refreshing scent • Aerosol\*
- Order No. **HPS-16** Jobber \$11.99

\* Hazardous goods fees apply when shipped air



CYLINDER HEAD REBUILDING  
CLEANING, ASSEMBLY & SAFETY  
SHORT BLOCK REBUILDING  
FLYWHEEL GRINDING  
CRANKSHAFT/ FLYWHEEL GRINDING  
MISCELLANEOUS TOOLS & SUPPLIES  
BRAKE & TIRE CHANGING TOOLS  
MEASURING TOOLS  
V-TWIN & METRIC HARD PARTS

full service  
...fast



"We are committed to maintaining your privacy. Information about you and your business is never sold, rented or given to anyone outside of our company."

- Sue, Goodson Database Manager - 31 years of service

# GOODSON

Tools and Supplies for Engine Builders

## SAVE!

Buy a complete set of  
8 or more segments and take 10% off jobber!



# Radiac

Abrasives

A TYROLIT Company

CYLINDER HEAD REBUILDING  
CLEANING, ASSEMBLY & SAFETY  
SHORT BLOCK REBUILDING  
CRANKSHAFT/ FLYWHEEL GRINDING  
MISCELLANEOUS TOOLS & SUPPLIES  
BRAKE & TIRE CHANGING TOOLS  
MEASURING TOOLS  
HARD PARTS

Silicon-Carbide  
Abrasive



Aluminum Oxide Abrasive



Aluminum Oxide &  
Silicon-Carbide  
Abrasive

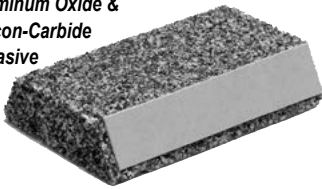

Aluminum  
Oxide  
Abrasive

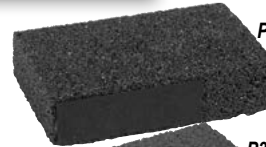

P337252



P348642

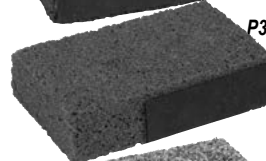

P337253



P348643

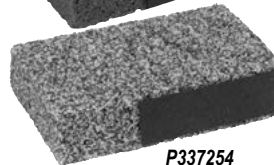

P337254

## Resurfacing Wheel Segments

Segments are available in a variety of compositions.

Match the abrasive to the material for best results and longest life. Order segments in 8, 10 or 12 piece sets.

Width	Thickness	Length	Application	Abrasive	Color	Jobber	Goodson Order No.	Color	Jobber	Radiac Order No.
2.56"/65mm	0.98"/25mm	3.94"/100mm	Cast Iron & Aluminum	Silicon-Carbide	Black	\$18.99	GS-PBS	Black	\$18.99	P337252
			Steel & Hardened Metals	Aluminum Oxide	White	22.99	GS-PBS-1			
			Aluminum, Cast Iron, Hardened Iron & Steel	Aluminum Oxide and Silicon-Carbide	Speckled	22.99	GS-PBS-2	Ruby	18.99	P337253
			Steel & Hardened Metals	Aluminum Oxide	Ruby	21.99	GS-PBS-3	Speckled	18.99	P337254
For Peterson/Peterson Berco 1055 AWL, RSC950 (std.), SYP320, -360, -1000, -1300, RSC1200, -1550, RPYS1500 models. For Winona Van Norman SM-2000, SM-4000/5000, MG-4000, SM-6000C/6000A and MG-3000/3850 models. For Storm Vulcan RT7Y Late (Serial No. 103152 and up) and RT 17Y Late (Serial No. 128697 and up) models.										
3.13"/79mm	0.81"/21mm	3.13"/79mm	Cast Iron & Aluminum	Silicon-Carbide	Black	\$21.99	GS-SVS	Black	\$29.84	P348642
			Aluminum, Cast Iron, Hardened Iron & Steel	Aluminum-Oxide and Silicon-Carbide	Speckled	21.99	GS-SVS-2	Ruby	19.99	P348643
For Peterson/Peterson Berco RG-32, RTY, RG-35, RG-300/900 models. For Storm Vulcan RT 7Y Early (Serial no. up to 103151) and RT 17Y Early (Serial no. up to 128696)										
1.97"/50mm	0.67"/17mm	3.62"/92mm	Cast Iron & Aluminum	Silicon-Carbide	Black	\$18.99	GS-RGS			
For Peterson/Peterson Berco RG-32, RG-300/900 models.										
2.56"/65mm	0.79"/20mm	3.94"/100mm	Steel & Hardened Metals	Aluminum Oxide	Black	21.99	GS-KWS			
			Aluminum, Cast Iron, Hardened Iron & Steel	Aluminum-Oxide and Silicon-Carbide	Speckled	21.99	GS-KWS-2			

For Kwik-Way 858 and 862 models

### tech tips

from the techxperts™

To maintain proper cutting action Goodson strongly recommends that you replace your cylinder head resurfacing segments in full sets. See your user's manual for wheel diameter and number of segments required. Due to manufacturing process colors may vary.

Need help choosing the abrasive? Call the Goodson Techxperts™

Resurfacing Segments are guaranteed for 1 year from original purchase date

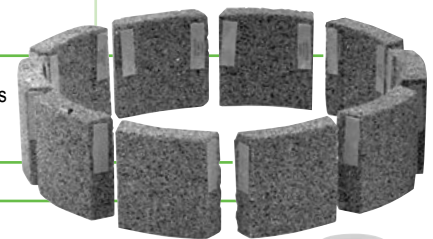

Buy 6 or more tubes,  
save 10% off jobber



## Grind Aid

- Cools and lubricates
- Stops premature grain fracturing
- Improves surface finish
- Handy twist tube with cover
- Reduces glazing and loading
- Essential when resurfacing aluminum heads
- Order No. **GRA-10** Jobber \$16.99

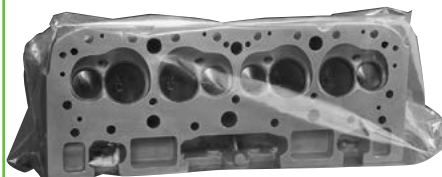

More storage bags  
on page 69

## Cylinder Head Storage Bags

- 3 mil thickness
- 17"x44" / 43.2 cm x 111.8cm
- 100 per roll
- Order No. **BC-17** Jobber \$69.99

## Rust Shield Aerosol\*

- Choose between short and long term protection
- Spray on right after resurfacing
- Remove short term with soap & water and long term with solvent



Formula Jobber Order No.

Short Term \$12.99 **RS-16**

Long Term 16.79 **RS-16-OD**

Order 6 or more cans, save 10% off jobber

\*Hazardous Goods Fees Apply When Shipped Air

# Cylinder Head Resurfacing

**Buy 3 or more,  
save 10% off jobber**  
**Buy 5 or more,  
save 15% off jobber**



## Cylinder Head Resurfacing Belts

A belt has three important abrasive, bond and backing. Our belts are made for top performance and long life. Our belts also feature a unique splice that permits use in both directions for even longer life when worn one way, turn belt around to resurface more heads.

**Abrasive:** Match the abrasive to the workpiece (aluminum, cast iron or steel) and to your machine for the longest belt life.

To check which size belt is needed to fit your machine, see the groups of resurfacers listed below.



### Silicon-Carbide 40-grit:

- Good-quality • Black
- Primarily for cast iron but can resurface aluminum if extra care is used
- Down-pressure optional
- \* SGS-14-86-60 is a 60 grit belt

### Silicon-Carbide 80-grit:

- Good-quality • Black
- Designed especially to resurface aluminum
- Down-pressure not recommended

### Ceramic 40-grit:

- Best-quality • Maroon
- Perfectly uniform grain
- Outlasts other types of belts
- For cast iron or steel
- Down-pressure recommended

### Nor-Zon® 40-grit:

- Better-quality
- Blue/Green
- Grains fracture under pressure to stay sharp
- For cast iron or steel
- Down-pressure recommended

### Zirconia Alumina 40-grit:

- Better-quality
- Excels on severe applications
- Grains fracture under pressure to stay sharp
- For stainless steel, alloy and aluminum

**new**

Belt Size	Machine	Jobber	Order No.	Jobber	Order No.	Jobber	Order No.	Jobber	Order No.	Jobber	Order No.
10" x 103"										\$56.99	SGZ-10-103
11 7/8" x 76"	(A)	\$34.99	SGS-11-76	\$37.99	SGA-11-76	—	—	\$79.99	SGB-11-76	56.99	SGZ-11-76
11 7/8" x 79"	(B)	36.99	SGS-11-79	37.99	SGA-11-79	—	—	74.99	SGB-11-79	56.99	SGZ-11-79
11 7/8" x 89"	(C)	37.99	SGS-11-89	44.99	SGA-11-89	—	—	79.99	SGB-11-89	—	—
11 7/8" x 91"	(D)	39.99	SGS-11-91	47.99	SGA-11-91	—	—	—	—	—	—
14" x 86"	(E)	44.99	SGS-14-86-60*	49.99	SGA-14-86	—	—	—	—	58.99	SGZ-14-86
14" x 103"	(F)	49.99	SGS-14-103	49.99	SGA-14-103	—	—	124.99	SGB-14-103	69.99	SGZ-14-103
14" x 107"	(G)	52.99	SGS-14-107	52.99	SGA-14-107	—	—	124.99	SGB-14-107	71.99	SGZ-14-107
14" x 113 1/2"	(H)	59.99	SGS-14-113	59.99	SGA-14-113	\$139.29	SCB-14-113	124.99	SGB-14-113	71.99	SGZ-14-113
15" x 127 1/2"	(I)	64.99	SGS-15-127	67.99	SGA-15-127	164.99	SCB-15-127	149.99	SGB-15-127	89.99	SGZ-15-127

A) Winona Van Norman BG-600 B) RMC, Peterson RG-1203 C) RMC-800, Serv-Equip PG-1229 D) Peterson RG-1234 & Kansas Instruments E) Automotive Craftsman F) Master Tool G) Kwik-Way 870 Master Surfer H) Storm Vulcan / Anderson AB-1000A, Peterson PG-1400 I) Storm Vulcan / Anderson AB-1540A, Anderson AB-1540, IDL HS-4350, Peterson PG-1500, Winona Van Norman BR-1500, BG-1515 & BG-1520

Colors may vary due to manufacturing process. Guaranteed for 1 year from original purchase date.



## Belt Resurfacer Coolant

- Semi-synthetic
- Rust-inhibiting
- For ALL belt resurfacers with a coolant sump
- Pink • Dilute 30:1

Size	Jobber	Order No.
1 Gallon / 3.79L	\$ 29.99	SGB-10
5 Gallons / 18.39L	144.99	SGB-50

## Save 10% on 10!

Order 10 or more Resurfacing Carbide Cutter Tips  
OR Rotary Broach Tool Bits and SAVE 10% off jobber



resharpening available



## Rotary Broach Tool Bit For Van Norman 530, 570 & VM-2000

- One-piece cutter
- Order No. **VN-65C** Jobber \$19.99

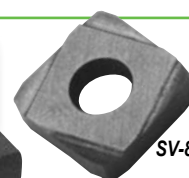

Enlarged for clarity

SV-85BE

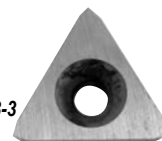

## Carbide Cutter Replacement Tips For Broach Style Surfacers

Fits	Jobber	Order No.
Storm Mill 85, 85B, 85BE, 85C, 85N & 280	\$28.99	SV-85BE
KW-858	34.99	FC-858-3

Selection Guide: which abrasive works best on what materials...

	ALUM	CAST IRON	STEEL
			Ceramic (40g)
			Nor-Zon® (40g)
			Zirconia Alumina (40g)
			Silicon-Carbide (40g)
			Silicon-Carbide (80g)

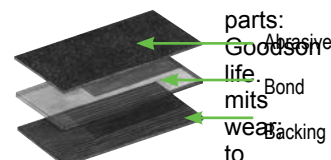

parts:  
Good abrasive life.  
Bond holds abrasive in place.  
Backing to wear to

**Bond:** Double-layer, heat-resistant resin holds abrasive firmly. Bond is so strong that grains wear out instead of loosening.

**Backing:** Waterproof, poly-back belt won't tear or fray. It's the toughest backing of any resurfacing belt.

CYLINDER HEAD REBUILDING  
CLEANING, ASSEMBLY & SAFETY  
SHORT BLOCK REBUILDING  
CRANKSHAFT/HEEL GRINDING TOOLS & SUPPLIES  
MISCELLANEOUS  
BRAKE & TIRE CHANGING TOOLS  
MEASURING TOOLS  
V-TWIN & METRIC HARD PARTS



"Goodson accepts major credit cards, debit cards, bank drafts and personal checks. Call us for more information."

- Bev, Goodson Accounting/Inventory Control Manager - 33 years of service

CYLINDER HEAD  
REBUILDING

CLEANING,  
ASSEMBLY & SAFETY

SHORT BLOCK  
REBUILDING

CRANKSHAFT/  
FLYWHEEL GRINDING

MISCELLANEOUS  
TOOLS & SUPPLIES

BRAKE & TIRE  
CHANGING TOOLS

MEASURING  
TOOLS

V-TWIN & METRIC  
HARD PARTS

## The most complete resurfacing program in the industry ...

### 1. Consistent high-quality abrasives

Each Goodson resurfacer wheel is made to the highest standards of roundness, balance and strength. Extensive quality control, start-to-finish, lets us back our abrasives with our Iron-Clad Guarantee\* of total satisfaction.

### 2. Full inventory

Since we specialize in the distribution of abrasives to machine shops world-wide we always carry an extensive inventory. We rarely put resurfacer wheels on back-order. Call Goodson, we have what you need on our shelves.

### 3. Same day shipping

We usually ship your order the same day that we receive it. If your order is received after 5:00pm Central Time, or on a week-end or holiday through our website, we will ship it the next business day. Along with our huge inventory, our shipping speed ensures consistently faster delivery when you order from Goodson.



### Surface Grinding Coolant

- Synthetic
- Water soluble
- Non-foaming • Dilute 20:1

Size	Jobber	Order No.
1 Gallon / 3.78 L	\$ 29.99	<b>SGC-10</b>
5 Gallons / 18.93 L	134.99	<b>SGC-50</b>

## Blanchard Cylinders

- Includes gasket pad for mounting onto a Blanchard Grinder
- Also ideal for resurfacing clutch plates
- Wheel measures 11" x 5" x 9"
- Tape wound for added safety
- Excellent grade for most grinding conditions and metals
- Order No. **U69755** Jobber \$159.99

**new**



## Single-piece Resurfacer Wheels

- Meet or exceed OE standards established for general purpose grinding applications
- Silicon-Carbide abrasive • Banding will wear off to expose more abrasive



GS-48



GS-50



GS-954

Peterson				Goodson		Radiac	
Machine Model(s)	Size: dia. x height x face width	Grit	Jobber	Order No.	Jobber	Order No.	
All 14" Dry Grinders	14" x 1 1/2" x 4" Plate	36	\$389.99	<b>GS-48</b>	\$347.99	<b>U338279</b>	
All 14" Dry Grinders	14" x 1 1/2" x 4" Plate	24	419.99	<b>GS-50</b>	347.99	<b>U342040</b>	
1054	16" x 2" x 2" Inserted Nut	16	409.99	<b>GS-954</b>			



GS-545



GS-545B



GS-545BL

Kwik-Way				Goodson		Radiac	
Machine Model(s)	Size: dia. x height x face width	Grit	Jobber	Order No.	Jobber	Order No.	
545,545H,855	12" x 3" x 1 1/2" (Serrated) Plate	16	\$384.99	<b>GS-545</b>			
545,545H,855	12" x 3" x 1 1/2" (Serrated) Plate	36			\$389.99	<b>U350423</b>	
545B,856,855-5,860	14" x 3" x 1 1/2" (Serrated) Plate	24	519.99	<b>GS-545B</b>			
545BL,860A, L & T	16" x 3" x 1 1/2" (Serrated) Plate	24	589.99	<b>GS-545BL</b>	499.99	<b>U342550</b>	
860A, L & T	16" x 3" x 1 1/2" (Serrated) Plate	36			499.99	<b>U422304</b>	

Grinding Wheels are guaranteed for 1 year from original purchase date



GS-10



GS-17A



FG-1165-G



FG-1070A-G

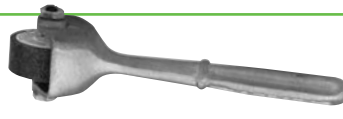

FG-1045-G



GS-14



GS-17

## Grinding Wheel Dressers & Replacement Cutters

Diamond Dresser Tools are available on pages 104-105

Applications	Cutter Assemblies			Replacement Cutters							
	OD	W	Jobber	Order No.	Pieces	Washers	OD	ID	Thick	Jobber	Order No.
VN, Lempco, Storm RT-7Y, 17Y	2.500"	1.625"	\$84.99	<b>GS-10</b>	14 stars	1 w/locking tangs	2.50"	1.50"	.062"	\$22.99	<b>GS-14</b>
Peterson (12mm shaft)	2.375"	1.625"	87.99	<b>GS-17A</b>	8 stars	5 1 w/locking tangs	2.375"	1.50"	.093"		
WVN SM2000, 4000, 5000, 6000C, 6000A, MG3000, 3850	1.250"	.978"	29.99	<b>FG-1165-G</b>	7 stars	none	1.25"	.313"	.095"	7.99	<b>FG-1161-G</b>
Peterson & DCM	2.375"	2.262"	69.99	<b>FG-1070A-G</b>	5 stars		2.375"	1.132"	.1375"	15.99	<b>FG-1070-G</b>
Hand held			49.99	<b>FG-1045-G</b>	1 stone	none	1.50"	.313"	.625"	13.99	<b>FG-1044-G</b>

# Vacuum Testers

**Goodson  
exclusive**

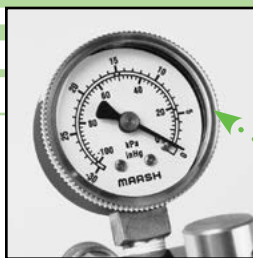

## Pistol Grip Vacuum Tester

- Lightweight - only 1.9 lbs. without the plate
- Pulls and holds up to 24 PSI vacuum on as little as 90 PSI
- Quick coupling Robinair fittings
- Easy to reach controls for single-handed operation
- Hard-anodized billet aluminum
- Tester includes one 4.75" vacuum plate

Description	Jobber	Order No.	Incl.
Pistol Grip Vacuum Tester Kit with 4.75" Vacuum Plate	\$599.99	DVC-2011	
<b>Optional Vacuum Plates</b>			
Robinair Fitting Replacement Plate Set	\$134.99	DVC-7KIT	▼
2.00" / 50.8mm Diameter Vacuum Plate	20.99	DVC-2	x
3.00" / 76.2mm Diameter Vacuum Plate	26.99	DVC-3	x
4.75" / 120.7mm Diameter Vacuum Plate	26.99	DVC-475	x
6.00" / 152.4mm Diameter Vacuum Plate	27.99	DVC-6	x
2"x3" / 50.8x76.2mm Vacuum Plate	21.99	DVC-23	x
3"x4" / 76.2x101.6mm Vacuum Plate	26.99	DVC-34	x
Plate Lube 8 oz. (236.6 mL)	5.99	DVC-PL	x
<b>Parts &amp; Accessories</b>			
Pressure Gauge	\$37.99	DVC-GAUGE	
Flexible Hose Kit w/3' Air Line (optional)	36.99	DVC-2011-HK	▼
1/8" NPT "L" Fitting	3.99	CF-2003-L	x
1/8" NPT Female Coupling	12.29	LDP-AR-6	x
Inline Air Filter	10.99	DVC-FILTER	x
1/8" x 1/4" Straight Fitting	5.99	DVC-SF	x
Nipple Coupling	6.99	DVC-1N	x
Air Line	lin. ft. price 1.99	CF-2001-AL	x
Robinair Fitting	5.29	DVC-SN	
1/8" NPT Male Coupling	14.99	DVC-1M	

Vacuum relief valve  
Exhaust port filter keeps the vacuum running smoothly and quietly

DVC-2011 comes complete with pistol grip and a 4.75" vacuum plate. Other plates shown below.

Optional Hose Kit includes 3 feet of 1/4" Air Line, L-Fitting, Filter, Straight Fitting, Robinair Fitting and Straight Coupler. All parts are also sold separately.

## Replacement Vacuum Tester Plates for Sioux™ 1630K

- Closed cell foam for an exceptional seal
- Replacement foam also available separately
- Several sizes to choose from or ask for a custom size
- Plate lube improves the seal for even better vacuum holding power

### Sioux-Style Replacement Plates for the 1630K Tester

Size	OE No.	Jobber	Order No.
2" / 50.8mm dia.	1630-2	\$31.99	SVT-2
3" / 76.2mm dia.	1630-3	31.99	SVT-3
4.75" / 120.7mm dia.	1630-4	31.99	SVT-475
6" / 152.4mm dia.	1630-6	34.99	SVT-6
2"x3" / 50.8 x 76.2mm		31.99	SVT-23
3"x4" / 76.2 x 101.6mm		31.99	SVT-34
Replacement Sioux-Style Fitting		13.99	DVC-SX

### Accessories & Replacement Parts

Description	Jobber	Order No.
6 Pc. Replacement Foam Set - 1 of each size	\$34.99	FOAM-KIT
Plate Lube - 8 oz. / 236.6 mL	5.99	DVC-PL
Replacement Line Filter	10.99	DVC-FILTER
Replacement Mat - 11" x 31" x 3/8"	39.99	DVC-1131

## Heavy Duty Manual Vacuum Tester

- Cover combustion chamber with rigid foam backed plate and pump vacuum
- A steady reading of 25" (63.5cm) indicates proper valve seating
- All metal construction
- 4 3/4" plate & fittings included
- DVC Plates (above) will fit this tester

Description	Jobber	Order No.
Manual Vacuum Tester	\$169.99	DVC-101-HD
Replacement 4.75" Plate	26.99	DVC-475

## Vacuum Testing

Vacuum testing is the fastest method for testing valve to seat integrity. Simply assemble your machined cylinder head and install the spark plugs. Use a reliable vacuum source producing approximately 24 lbs. HG on the vacuum gauge and a closed cell foam test plate with a through fitting to draw down or evacuate the combustion chamber.

Once you've reached 24 lbs. HG on the gauge and close the vacuum to the chamber. Watch the gauge for a drop in vacuum. It should hold steady confirming that you have achieved valve to seat mating.

Coat the face of your closed cell foam test plate with Plate Lube (DVC-PL) to condition the foam. This produces a soft, yielding material that will fill minor head surface blemishes or imperfections.

**tech tips**  
from the techxperts™

CYLINDER HEAD  
REBUILDING

CLEANING,  
ASSEMBLY & SAFETY

SHORT BLOCK  
REBUILDING

FLYWHEEL GRINDING  
TOOLS & ACCESSORIES

CRANKSHAFT/  
MISCELLANEOUS

BRAKE & TIRE  
CHANGING TOOLS

MEASURING  
TOOLS

V-TWIN & METRIC  
HARD PARTS

... another satisfied customer

"Goodson's Fluorescent Magnetic Powder works great! Cracks glow bright yellow under black light. We find the fluorescent powder much more effective at picking up cracks than any powder that we have used in thirty years of crack detection."  
Steve & Ed Walsh - Steve's Machine Shop Service Liberty, NY, Goodson Customer since 1994

CYLINDER HEAD  
REBUILDING

CLEANING,  
ASSEMBLY & SAFETY

SHORT BLOCK  
REBUILDING

CRANKSHAFT/  
FLYWHEEL GRINDING

MISCELLANEOUS  
TOOLS & SUPPLIES

BRAKE & TIRE  
CHANGING TOOLS

MEASURING  
TOOLS

V-TWIN & METRIC  
HARD PARTS



**Specifications**

**MMP-100 / MMP-100S**  
Physical: 7 3/8" x 9 1/4" x 2 1/8"  
187 x 235 x 54mm  
Max. Span: 12" (304.8mm)  
across poles  
Voltage: 115V (MMP-100)  
230V (MMP-100S)  
Line Current: 4 amp (MMP-100)  
3 amp (MMP-100S)  
Weight: 6.5 lb (2.95 kg)  
Cord: 10' L, 3-wire

**MMP-210 / MMP-210S**  
Physical: 10 1/2" x 11" x 2 3/4"  
266 x 280 x 70mm  
Max. Span: 18" (457mm) across  
poles  
Voltage: 115V (MMP-210)  
230V (MMP-210S)  
Line Current: 8 amp (MMP-210)  
3 amp (MMP-210S)  
Weight: 13 lb (5.9 kg)  
Cord: 10' L, 3-wire

**MMP-100**

Articulating legs adjust to a wide range of angles, allowing you to test uneven surfaces with ease

**MMP-210**



**Magnetic Crack Detection Units**

- Articulating legs conform to virtually any surface configuration
- Designed for one-person operation • Lightweight
- No transformer box to drag around • 230V units feature a pigtail on the cord
- Easy to access switches • Full 1-Year Manufacturer's Warranty for Repair
- 50% duty cycle (example: 2 minutes on, 2 minutes off)
- Produce a strong AC magnetic field

Description	Jobber	Order No.
115V Electronic Crack Detector with 10# Pull	\$524.99	<b>MMP-100</b>
115V Heavy Duty Electronic Crack Detector with 22# Pull	679.99	<b>MMP-210</b>
230V Electronic Crack Detector with 10# Pull	529.99	<b>MMP-100S</b>
230V Heavy Duty Electronic Crack Detector with 22# Pull	679.99	<b>MMP-210S</b>

**American Made**  
**Non-Fluorescent**  
**Magnetic Powder for**  
**Dry Method Particle**  
**Inspection**

- Works with all dry magnets including Magnaflux® and Parker
- Store in a moisture free environment



Color/Size	1 lb.	5 lb.	25 lb.
White	<b>WCD-100-G</b>	<b>WCD-500-G</b>	<b>WCD-2500-G</b>
Yellow	<b>WCD-101-G</b>	<b>WCD-501-G</b>	<b>WCD-2501-G</b>
Red	<b>WCD-103-G</b>	<b>WCD-503-G</b>	<b>WCD-2503-G</b>
Jobber	\$9.99	\$47.99	\$217.99

**13W**  
**Fluorescent**  
**UV Leak Detection Light**

- Uses a single 13W Ultraviolet fluorescent bulb • Effective up to 24" from surface • Nylon-tipped double hooks for hands-free use • Rocker style switch • 25' 18/2 power cord
- Measures 11.3"L x 2.3"W x 2.3"D • Weighs just 35.2 oz.
- 1 year limited warranty



Description	Jobber	Order No.
Fluorescent Detection Light	\$69.99	<b>GLO-4</b>
Replacement Bulb	39.99	<b>GLO-4-B</b>

**American Made**  
**Green Fluorescent**  
**Magnetic Powder**

- For dry magnetic inspection methods
- Makes crack detection easier
- Cracks glow bright yellow under ultraviolet light but can also be seen under normal lighting conditions

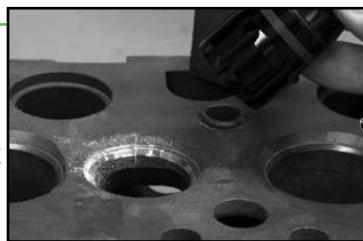

Quantity	Jobber	Order No.
1 lb.	\$ 19.99	<b>FCP-107-G</b>
5 lb.	89.99	<b>FCP-507-G</b>
25 lb.	419.99	<b>FCP-2507-G</b>

**Magnetic Powder**  
**Applicators**

- A quick & easy method for distributing magnetic powder

Description	Jobber	Order No.
Atomizer Assembly for small areas (1 oz.)	\$24.99	<b>MM-301</b>
Applicator Bulb for large areas	19.99	<b>WCD-266-G</b>
Replacement Bulb for Atomizer Jar	12.79	<b>MM-301-1</b>



# tech tips

from the techxperts™

It is essential that you measure residual magnetism when using magnetic crack inspection. Magnetic fields are measured in gauss and the gauge used to measure it is a magnetic field indicator (MFI-10010 below). To see if you have any residual magnetism in your components, simply hold the field indicator close to the part. If it doesn't read "0", you have magnetism.

**Goodson  
exclusive**



FCD-KIT



FCD-HP-KIT

## Magnetic Crack Inspection Kits

Goodson carries a variety of magnetic crack detection methods including these two kits. We include heavy-duty 110V adjustable-leg magnets that are made right here in America. Kits also include lights, magnetic powder atomizers, and fluorescence enhancing safety glasses. All items are also available separately.

Description	Jobber	Order No.	Incl.
Fluorescent Magnetic Crack Detection Kit	\$799.99	FCD-KIT	▼
High Performance Fluorescent Crack Detection Kit	899.99	FCD-HP-KIT	▼
115V Heavy Duty Electronic Crack Detector	679.99	MMP-210	x x
Magnetic Powder Atomizer Assembly (1 oz. capacity)	24.99	MM-301	x x
Magnetic Crack Detection Oil Spray*	29.99	MFA-16*	x
AC Blacklight	69.99	GLO-4	x
Fluorescence Enhancing Glasses	19.99	GLO-9940	x
Compact LED UV Inspection Light Kit (Glasses included)	159.99	GLO-400	x
Fluorescent Magnetic Powder 1 lb.	19.99	FCP-107-G	x x

\*Hazardous Goods Fees Apply When Shipped Air

CYLINDER HEAD  
REBUILDING  
CLEANING,  
ASSEMBLY & SAFETY  
SHORT BLOCK  
REBUILDING  
FLYWHEEL GRINDING  
CRANKSHAFT/  
GRINDING  
MISCELLANEOUS  
TOOLS & SUPPLIES  
BRAKE & TIRE  
CHANGING TOOLS  
MEASURING  
TOOLS  
V-TWIN & METRIC  
HARD PARTS

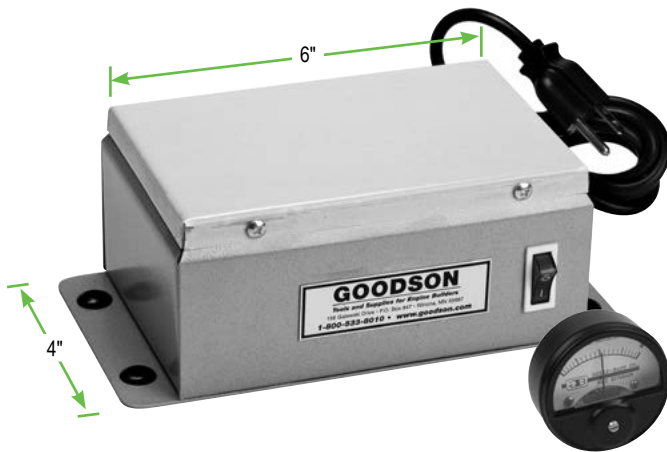

## Small Parts Demagnetizer

Don't jeopardize your engine work! Heat, friction and magnetic particle inspection can cause magnetism to build up in your engine components. If not removed, it will attract ferrous materials in engine lubrication and may cause premature engine failure. This easy to use table demagnetizer is a fast and easy way to ensure that all residual magnetism is eliminated from engine components. Use with the optional Magnetic Field Indicator (MFI-10010) to be sure all remaining magnetism is eliminated.

Description	Jobber	Order No.
Small Parts Demagnetizer	\$84.99	SPD-46
Magnetic Field Indicator	64.99	MFI-10010



GLO-400

## Compact 100W LED UV Crack Inspection Light

- Power comparable to high-intensity 100-watt lamps
- Inspection range of up to 10 feet (3M)
- Compact design fits easily into tight, cramped spaces
- 100 thousand hour LED service life
- Rugged, corrosion-resistant, anodized aluminum lamp body stands up to years of heavy shop use
- Rechargeable lithium-ion battery (included) provides 4 hours of continuous inspection between charges
- Includes AC charger, fluorescence enhancing glasses and lanyard
- Order No. **GLO-400** Jobber \$159.99



"At Goodson, we're always on the lookout for new or improved tools that make engine rebuilding easier. If you have a tool you think we'd be interested in, give us a call."

- Dave, Goodson National Sales Manager, 21 yrs. of service

CYLINDER HEAD  
REBUILDING

CLEANING,  
ASSEMBLY & SAFETY

SHORT BLOCK  
REBUILDING

CRANKSHAFT/  
FLYWHEEL GRINDING

MISCELLANEOUS  
TOOLS & SUPPLIES

BRAKE & TIRE  
CHANGING TOOLS

MEASURING  
TOOLS

V-TWIN & METRIC  
HARD PARTS

Identify surface cracks in minutes!

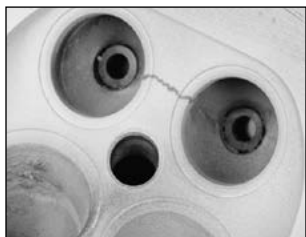

### Alumni-Chek

- Find surface cracks on aluminum & cast iron without electricity or special lights
- Ideal for aluminum, but also works on brass, cast-iron, steel, carbide, and Stellite • Even the tiniest cracks show as bright red • Complete kit includes Cleaner, Penetrant, Developer and Shop Towels (also available separately)

Description	Jobber	Order No.	Incl.
<b>Complete Kit</b>	\$46.99	<b>AC-KIT*</b>	▼
Cleaner Aerosol	19.99	<b>AC-1*</b>	x
Penetrant Aerosol	19.99	<b>AC-2*</b>	x
Developer Aerosol	19.99	<b>AC-3*</b>	x
<b>5 Towels</b>	3.99	<b>WST-5</b>	x

Mix or match Cleaner, Penetrant & Developer to make a case of 12 and SAVE 10% OFF Jobber!

\*Hazardous Goods Fees apply when shipped by air



## tech tips

from the techxperts™

**Step 1:** Spray cleaner evenly on the surface and allow it to dry completely.

**Step 2:** Spray on Penetrant. Allow to saturate for 5 minutes. Wipe off excess to avoid false readings.

**Step 3:** Spray on thin layers of developer to build up a uniform powdery film.

**Step 4:** Flaws and cracks will glow brightly when viewed under the black light (Applies only to Goodson Glow).



### GOODSON Glow Blacklight Crack Detection Kit

- Easily detect surface cracks that could easily be missed with just visual inspection
- Cracks & flaws glow brightly under black light after treatment with Cleaner, Penetrant and Developer

Description	Jobber	Order No.	Incl.
<b>Goodson Glow Kit</b>	\$129.99	<b>GLO-KIT*</b>	▼
Cleaner Aerosol	19.99	<b>GLO-1*</b>	x
Penetrant Aerosol	23.99	<b>GLO-2*</b>	x
Developer Aerosol	29.99	<b>GLO-3*</b>	x
<b>110V Blacklight</b>	69.99	<b>GLO-4</b>	x
<b>5 Cloth Towels</b>	3.99	<b>WST-5</b>	x
<b>Replacement Bulb for GLO-4</b>	39.99	<b>GLO-4-B</b>	

Mix or match Cleaner, Penetrant & Developer to make a case of 12 and SAVE 10% OFF Jobber.

\*Hazardous Goods Fees apply when shipped by air



## tech tips

Keep all Ultra-Violet and Black Lights a minimum of 18" from magnetic fields to from the techxperts™ prevent damage to the tungsten element and voiding the warranty.



### Ultra-Violet Light Inspection

- Put into a running engine to find hidden leaks
- Check engines, transmissions and radiators **IN** the vehicle
- Use before disassembly to plan repairs
- Use after rebuilding to ensure satisfaction, or to find and fix warranty complaints
- Add dye to oil, coolant or fluid • No pre-cleaning required
- Run vehicle briefly to distribute the dye • Inspect with UV light • Finds even the tiniest of leaks

Description	Jobber	Order No.
<b>Light</b>	150W-110VAC light assembly	\$554.99 <b>GLO-300</b>
<b>Replacement Bulbs</b>	150W-110VAC bulb only (Model 1610)	169.99 <b>GLO-150WB</b>
	120W-110VAC bulb only (Model 1210)	169.99 <b>GLO-120WB</b>
<b>Lens</b>	Ultra-violet lens	59.99 <b>GLO-LENS</b>
<b>Dye</b>	Oil Dye for gasoline engines (1 fl. oz.)	10.99 <b>GLO-GED</b>

### Crack Detection Powder & Oil Carrier

- For wet method crack detection
- Mix powder with oil carrier
- Use **GLO-300** Light (left) to view results

	Size	Jobber	Order No.
<b>Powder</b>	4 oz. / 113.4g	\$ 49.99	<b>GCR-14A-4</b>
	1 lb. / 453.6g	189.99	<b>GCR-14A</b>
<b>Oil Carrier</b>	5 gallons / 18.93L	134.99	<b>GCR-50</b>



### Magnetic Crack Detection Oil & Spray

- Oil impregnated with magnetic powder (**GCR-14**) to glow under black-light • Low viscosity
- Flows easily into small cracks
- Oil clarity makes cracks easier to see



Description	Jobber	Order No.
<b>Aerosol* 16 oz.</b>	\$ 29.99	<b>MFA-16*</b>
<b>5 gallons / 18.93 liter</b>	157.99	<b>MFA-50</b>

\*Hazardous Goods Fees Apply When Shipped Air

## Threaded Crack Repair Plugs

- Iron • Tapered • Threaded plugs
- Cast to rigid specifications

Plug Size	Qty.	Jobber	Order No.
.200" x 1/8"	100	\$104.99	<a href="#">CRP-200</a>
.200" x 1/2"	100	109.99	<a href="#">CRP-201</a>
.235" x 1/8"	100	109.99	<a href="#">CRP-235</a>
.327" x 1/8"	50	109.99	<a href="#">CRP-327</a>



## High Speed Steel Drills

- 118° points for fast chip removal

Plug Size	Jobber	Order No.
.200"	\$6.29	<a href="#">CRD-200</a>
.235"	6.29	<a href="#">CRD-235</a>
.327"	6.29	<a href="#">CRD-327</a>



## Tapered Reamers

- High Speed Steel

Plug Size	Jobber	Order No.
.200"		Not Required
.235"	\$ 78.79	<a href="#">CRR-235</a>
.327"	115.49	<a href="#">CRR-327</a>



## Tapered Taps

- High strength steel machined to match plug taper & thread

Plug Size	Jobber	Order No.
.200"	\$66.29	<a href="#">CRT-200</a>
.235"	60.79	<a href="#">CRT-235</a>
.327"	80.49	<a href="#">CRT-327</a>



## Ceramic Motor Seal

- Permanently seals leaking head gaskets, cracked heads and blocks (aluminum or cast iron)
- Coats the engine to inhibit rust formation and salt water corrosion during normal operation
- Seals porous castings in the cooling system
- Stops coolant leaks
- Promotes heat dissipation for added power
- 16 oz./455 mL
- Order No. [CRS-16](#) Jobber \$21.99



## Rust Inhibitor for Pressure Testing

- Clear fluid inhibits rust and does not discolor or cloud the test tank solution
- Lets you see better to pressure test
- Biocide and anti-rust additives extend tank solution life while preventing corrosion
- Synthetic formula
- Mix 20:1 with water
- Yields 20 gallons
- Order No. [PRI-10](#) Jobber \$29.99



## .235" Crack Repair Kit

- For the cold-repair process • Includes manual

Description	Jobber	Order No.	Incl.
Complete Repair Kit:	\$379.99	<a href="#">CRK-150</a>	▼
100 - .235" x 1/8" Threaded Iron Plugs	109.99	<a href="#">CRP-235</a>	x
High Strength Steel Drill	6.29	<a href="#">CRD-235</a>	x
High Strength Steel Tapered Reamer	78.79	<a href="#">CRR-235</a>	x
High Strength Steel Tapered Taps (2)	60.79	<a href="#">CRT-235</a>	x
Cut-Off Saw with Blade	25.29	<a href="#">CR-SAW</a>	x
Replacement Saw Blade	9.49	<a href="#">CR-BLADE</a>	x
7.5 oz. Tap Oil	15.79	<a href="#">TAP-O</a>	x
All Weather Seal	18.99	<a href="#">AWS-16</a>	x
16 oz. Ceramic Seal	21.99	<a href="#">CRS-16</a>	x



## Jet Valve Eliminator Kit

- Some Mitsubishi/Chrysler 2.6L heads had jet valves while some didn't
- This kit lets you use a jet valve equipped head in place of one without
- 11mm diameter, 1.0 pitch threaded plugs replace entire valve body assembly
- Easier than welding the holes closed
- Package of 4 converts one 2.6L head
- Order No. [JVE-26](#) Jobber \$24.99



## Head-Bolt Hole Clean-out Taps

- Clean threaded holes to prevent false torque wrench readings
- Lifts rust, dirt, chips and other debris as you remove the tool
- Use with lube and a socket wrench or slow drill
- Repairs minor damage

Size	Pitch	Length	Jobber	Order No.
1/2"	13	3 3/8" OAL	\$ 49.99	<a href="#">BCT-1/2</a>
7/16"	14	3 3/8" OAL	49.99	<a href="#">BCT-7/16</a>
10mm	2.0mm	8" Shank	For LS1 139.99	<a href="#">BCT-10X2L</a>
11mm	1.5mm	8" Shank	119.99	<a href="#">BCT-11L</a>
11mm	2.0mm	8" Shank	For LS1 149.99	<a href="#">BCT-11X2L</a>



**PROBLEM:** Due to poor lubrication, the rear bushing on the upper balance shaft of Mitsubishi built Chrysler 2.0L engines galls to the shaft and spins. Repairing the damaged bore is costly and often requires another block.

**SOLUTION:** This kit eliminates both balance shafts so the original block can be reused, saving money and ending future shaft problems. It also reduces total friction and improves oil flow to the head. Some vibration may occur at idle, but engine operation is unaffected by balance shaft removal.



## Balance Shaft Eliminator Kits For Mitsubishi-Built Engines

- Includes 2 bushings (44 & 45mm), oil pump plug & welch plug • Order No. [BSE-20](#) Jobber \$36.99

CYLINDER HEAD REBUILDING  
CLEANING, ASSEMBLY & SAFETY  
SHORT BLOCK REBUILDING  
CRANKSHAFT/ FLYWHEEL GRINDING  
MISCELLANEOUS TOOLS & SUPPLIES  
BRAKE & TIRE CHANGING TOOLS  
MEASURING TOOLS  
V-TWIN & METRIC HARD PARTS



"You always get more than great products from Goodson ... you also get great value!"  
— James, Goodson Shipping/Receiving, 1 year of service

CYLINDER HEAD  
REBUILDING

CLEANING,  
ASSEMBLY & SAFETY

SHORT BLOCK  
REBUILDING

CRANKSHAFT/  
FLYWHEEL GRINDING

MISCELLANEOUS  
TOOLS & SUPPLIES

BRAKE & TIRE  
CHANGING TOOLS

MEASURING  
TOOLS

V-TWIN & METRIC  
HARD PARTS

shown actual size



melted center reveals  
overheating



### Heat Tabs

- Provides visual evidence of engine overheating
- Special heat sensitive metal centers melt and fall out when engine exceeds the melting point of the tab
- Marine Heat Tabs are sold in packs of 50, all others are 100 per pack
- Attach to heads with Heat Tab Adhesive (below)

Description	Melting Point	Jobber	Order No.
Automotive Heat Tabs	255-260° F / 124-127° C	\$42.99	<b>RHT-100</b>
Round Heat Tabs	255-260° F / 124-127° C	69.99	<b>HT-100RD</b>
Diesel Heat Tabs	225-235° F / 107-110° C	52.49	<b>DHT-100</b>
Marine Heat Tabs	187-192° F / 86-89° C	59.99	<b>MHT-50</b>
Heat Tab Adhesive (3 oz./88.7mL tube)		8.99	<b>HTA-3</b>

## tech tips

from the techxperts™

### Protect yourself from unjustified warranty claims with a simple Heat Tab

When you attach a heat tab to the engine it provides visual evidence that an engine has been overheated. A special heat sensitive metal has been formed into the center of the tab. When an engine reaches the tab's melting point, this metal will melt and flow out. This is a positive method of determining that a rebuilt engine has been heated beyond normal operating temperature, voiding the warranty. Attach a Heat Tab to the upper portion of the block or to the cylinder head casting with **HTA-3** Aluminum Paste (above). **DO NOT** attach to manifolds or shielding.

### Leak Detection Mat

- Commercial-grade Neoprene
- Resists petroleum products, abrasion, swelling, sunlight and aging
- Repair worn mats or make custom leak detection plates
- Measures 3'x4'x1/8" thick (914.4x1219.2x3.175mm)
- Order No. **LDP-34MAT** Jobber \$87.99



### Seal-All™

- Seals pin holes, porosity and small cracks in heads & blocks
- Penetrates and seals
- Out-performs ceramics
- Bonds with existing rust & corrosion to prevent spread
- Heat at 175°-200°F (79.4°-93.3°C) for 4 hours to cure
- Not for use on assembled engines
- 32 oz. (46 mL)
- Order No. **CPS-32** Jobber \$69.99



### Fluid Weld®

- For cast iron or aluminum heads and blocks
- Use as a sealant for threaded or press-fit parts like valve guides and seats, threaded crack repair plugs, replacement studs, etc.
- Seals small cracks • Non-toxic
- Non-flammable
- **NOT** for use on assembled engines
- Withstands temperatures to 3000°F



Size	Jobber	Order No.
2 oz. (59 mL)	\$ 44.99	<b>FW-2</b>
8.8 oz. (260 mL)	137.99	<b>FW-88</b>

### All Weather Seal

- Seals intakes & head gasket leaks
- Seals cracks in cylinder heads & engine blocks
- Prevents anti-freeze seepage through gaskets and hoses
- Lubricates water pump seals
- Mixes with all anti-freeze and coolant
- Works in less than 5 minutes
- Fast-acting, non-corrosive, non-clogging
- Can be used with coolant or anti-freeze
- 16 oz./455 mL • Order No. **AWS-16** Jobber \$18.99



**For use in a running engine!**

### Engine Seal Tabs Seal And Prevent Leaks In Any Cooling System

- Use in a running engine
- For water leaks in cylinder heads, blocks, radiators, water pumps, heater cores, manifolds, etc.
- 3 1/2 gram tablets treat up to a 9 quart cooling system
- 20 tabs per pack
- Order No. **EST-10** Jobber \$29.99



## Convert your Bridgeport-type mill into a cylinder head machining center!



Lock the fixture to your mill bed using your standard T-Bolts (not included)

Two towers secure to the mill bed and support the cradle assembly

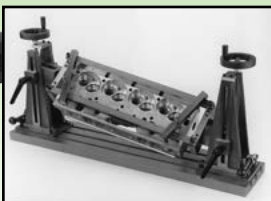

### Vertical Mill Heavy-Duty 360° Roll-Over Fixture

- Uses the Universal Quick-Mount Bar Set (included) to hold the workpiece securely in place
- Position workpieces quickly & accurately
- Locks to your table using your standard T-nuts
- Handles workpieces up to 24" long
- Cradle accommodates in-line and canted valves with offset movement up to 15°
- Width adjusts in ¼" increments • Instructions included
- Quick-Mount Bar Set can also be used as a replacement on most popular seat & guide machines

Description	Jobber	Order No.
Roll-Over Fixture with Quick-Mount Bar Set	\$1999.99	<b>VM-42</b>
Replacement Quick-Mount Bar Set	159.99	<b>QMB-95</b>

### GM Vortec Adaptor Plate Set For Van Norman & Storm-Vulcan Rotary Broaches

- Required when using the Van Norman VN 530 / 570 or Storm-Vulcan 850 Storm-Mill Rotary Broaches
- Two plate set • Includes fasteners
- Order No. **VN-VOR** Jobber \$99.99



### Installation



1 - Insert stud into correct size installer.



2 - Hand set the stud into the cylinder head



3 - Use a standard ¾" wrench or socket to tighten stud into place. Each installer is fitted with a steel ball inside to prevent over-tightening.

### Removal



1 - Place the remover over the stud to be removed. Using 2 wrenches, back the stud out of the head.

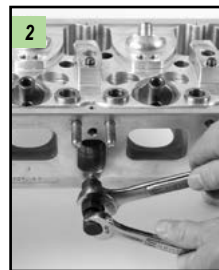

2 - Removers can be used in virtually any position.



### Stud Removal and Installation Tooling

- Size stamped for easy identification
- Installers include a steel ball inside to prevent overtightening on the stud
- Removers have a ¼" OD Hex body with a ⅝" hex jam nut on top

Description	Jobber	Order No.
Stud Installers	¼" Fine	\$21.99 <b>ASI-250</b>
	⅜" Fine	21.99 <b>ASI-312</b>
	½" Fine	21.99 <b>ASI-375</b>
	⅝" Coarse	21.99 <b>ASI-375C</b>
	¾" Fine	21.99 <b>ASI-437</b>
	1" Fine	21.99 <b>ASI-500</b>
	1 ¼" Fine	21.99 <b>ASI-562</b>
Stud Removers	¼" Fine	\$29.99 <b>ASR-250</b>
	⅜" Fine	29.99 <b>ASR-312</b>
	½" Fine	29.99 <b>ASR-375</b>
	⅝" Coarse	29.99 <b>ASR-375C</b>
	¾" Fine	29.99 <b>ASR-437</b>
	1" Fine	37.99 <b>ASR-500</b>
	1 ¼" Fine	37.99 <b>ASR-562</b>



"Our Top Alcohol Dragster cylinder heads have about a zillion studs of various sizes. With the Goodson Stud Removers and Installers, we now make short work out of this very tedious process."

- Dean Dubbin, DPM Awnings (NHRA Top Alcohol Dragster), Goodson customer since 2010

CYLINDER HEAD REBUILDING  
CLEANING, ASSEMBLY & SAFETY  
SHORT BLOCK REBUILDING  
CRANKSHAFT/ FLYWHEEL GRINDING  
MISCELLANEOUS TOOLS & SUPPLIES  
CHANGING TOOLS  
MEASURING TOOLS  
V-TWIN & METRIC HARD PARTS



"We reward you for prompt payment! You can take a 1% discount on merchandise if the payment is made within 15 days of the invoice date. Just check the bottom left corner of your invoice for the prompt payment discount."

— Roger, Goodson Controller, 16 years of service

CYLINDER HEAD  
REBUILDING

CLEANING,  
ASSEMBLY & SAFETY

SHORT BLOCK  
REBUILDING

CRANKSHAFT/  
FLYWHEEL GRINDING

MISCELLANEOUS  
TOOLS & SUPPLIES

BRAKE & TIRE  
CHANGING TOOLS

MEASURING  
TOOLS

V-TWIN & METRIC  
HARD PARTS

### Aluminum Cylinder Head Straightening Fixture

- Straightens aluminum heads warped up to .040", returning them to ±.005" of the original • Easy to use • Mehonite fixture is rigid as 3" steel yet weighs less • Stress-relieved then milled to .001"
- Can resurface fixture if necessary • Includes shim stock and all hardware • 29"L for 4-cylinder & most 6-cylinder
- Order No. **HSF-500** Jobber \$299.99

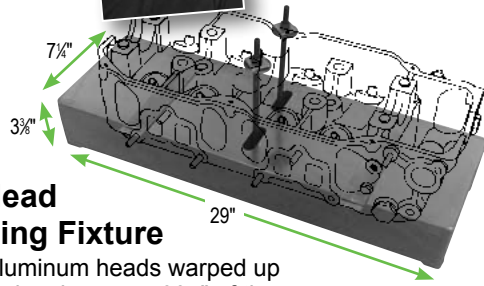

### Temperature Indicating Crayons

- Mark the workpiece before heating
- Crayon melts when temp is reached
- 3 temps to choose from

Melting Point	Jobber	Order No.
450°F/232.22°C	\$17.99	<b>TIC-450</b>
500°F/260.00°C	17.99	<b>TIC-500</b>
600°F/315.56°C	17.99	<b>TIC-600</b>

Buy 3  
crayons,  
get 10%  
off jobber



### Gauntlet Style Heat & Flame Resistant Gloves

- Heavy, lined red terrycloth
- Safe to 450°F / 232.2°C
- 13 1/2" Long
- Order No. **HFR-300** Jobber \$29.99

American Made

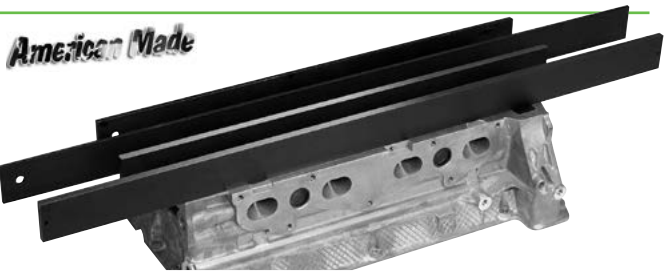

### Precision Steel Straight Edges

Description	Jobber	Order No.
24" straightedge, 1 precision edge	\$119.99	<b>DIS-24</b>
36" straightedge, 1 precision edge	129.99	<b>DIS-36</b>
24" straightedge, 2 precision edges	159.99	<b>DIS-20</b>
35" straightedge, 2 precision edges	179.99	<b>DIS-30</b>

### 26" Round Warp Gauge

- Use with feeler gauges page 55

Description	Jobber	Order No.
3/4" dia. tool steel, 26" long	\$139.99	<b>EWG-100</b>

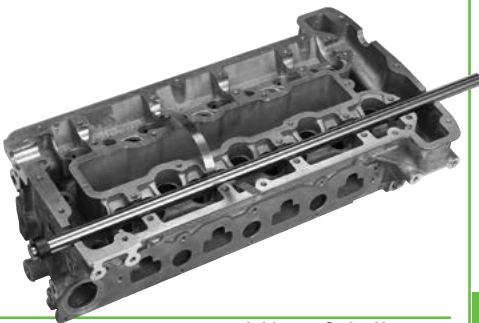

### Brass or Steel Shim Stock Packs

- A handy assortment • 4" x 6" each (120 sq. in.)
- One each of .001", .002", .003", .005", .010" thick

Description	Jobber	Order No.
Brass	\$12.99	<b>SSB-50</b>
Steel	12.99	<b>SSS-51</b>

Use with our Head Straightening Fixture and Oven above

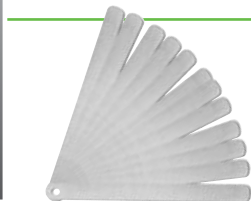

### 12" Feeler Gauges

- Use to measure piston-to-wall clearance when honing, to find ring end gap and to check cylinder heads with a straight-edge
- Also useful for shimming while straightening heads and for machine set-ups

Thicknesses	Jobber	Order No.	
<b>Complete Kit</b>	<b>\$39.99</b>	<b>FE-KIT</b>	▼
.0015"	5.99	<b>FE-0015</b>	x
.0020"	5.99	<b>FE-002</b>	x
.0030"	5.99	<b>FE-003</b>	x
.0040"	5.99	<b>FE-004</b>	x
.0050"	5.99	<b>FE-005</b>	x
.0060"	5.99	<b>FE-006</b>	x
.0070"	5.99	<b>FE-007</b>	x
.0080"	5.99	<b>FE-008</b>	x
.0090"	5.99	<b>FE-009</b>	x
.0100"	5.99	<b>FE-010</b>	x
.0150"	5.99	<b>FE-015</b>	x
.0200"	5.99	<b>FE-020</b>	x

### Universal Gel Lube

- Sprays on as a liquid and forms into a gel within seconds
- Penetrating formula blends with motor oil
- Originally developed for valve spring break-in, but can be used for cams, lifters, rocker arms, bearings, pistons/wrist pins, cylinders, etc.
- Provides lubrication for engines subjected to prolonged storage before initial start-up
- Aerosol\* • Order No. **GL-8U** Jobber \$17.99

\* Hazardous Goods Fees Apply If Shipped Air



### Spray Assembly Lube

- Ideal for pre-lubricating parts to ease assembly
- Eliminates critical initial run-in of new and rebuilt high-performance engine components
- Spray on bearings, crankshafts, pistons, rings, etc.
- Aerosol\* • Order No. **SAL-11** Jobber \$13.79

\* Hazardous Goods Fees Apply If Shipped Air



Buy 6 or more cans of **GL-8U** and **SAL-11** (any combination) and save 10% off jobber



# Miscellaneous Cylinder Head

Buy 5 or more packs of VADs (any combination of sizes), Save 10% off Jobber



## Adjust Clearance Between Valve Stem and Cams with Valve Adjustment Discs



- Ideal for most import engines
- To select the Valve Adjustment Disc for your job consult the Manufacturer's Specifications for the correct diameter and thickness

Diameter	Thicknesses available	4-Packs of Individual Sizes	
		Jobber	Order No.
28mm	2.50, 2.55, 2.60, 2.65, 2.70, 2.75,	\$16.99	VAD-(thick)MM-28
	2.80, 2.85, 2.90, 2.95, 3.00, 3.05,		
	3.10, 3.15, 3.20, 3.25		
34mm	2.20, 2.25, 2.30, 2.35, 2.40, 2.45,	16.99	VAD-(thick)MM-TY
	2.50, 2.55, 2.60, 2.65, 2.70,		
	2.75, 2.80, 2.85, 2.90, 2.95, 3.00,		
	3.05, 3.10, 3.25		

VADs are NOT sold by application, but by diameter and thickness. Please consult manufacturer's specifications before ordering.

## Mercedes .015" Head Saver Shims



- Shim cam towers if more than .015" is removed when resurfacing head
- Restores valve clearance & timing
- For 4, 5 & 6-cylinder Mercedes gas or diesel engines
- Each set shims all cam towers in one head
- Order No. **MHS-40** Jobber \$12.99

## Rocker Arm Pedestal Shims

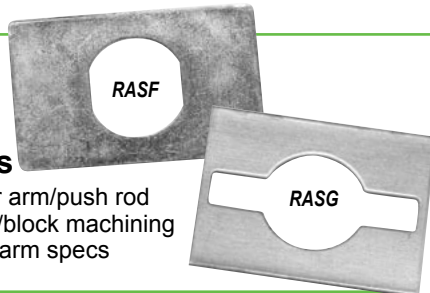

- Compensate rocker arm/push rod distance after head/block machining
- Use original rocker arm specs

Application	Qty.	Jobber	.010" Thick		.020" Thick	
			Order No.	Jobber	Order No.	Jobber
Ford 302/351	50	_____	_____	\$12.79	RASF-20-50	
Ford 302/351	100	_____	_____	20.99	RASF-20-100	
GM 3.1L, V6	50	\$19.99	RASG-10-50	12.79	RASG-20-50	
GM 3.1L, V6	100	27.99	RASG-10-100	20.99	RASG-20-100	

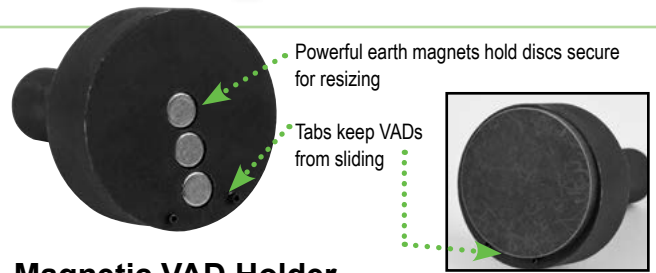

Powerful earth magnets hold discs secure for resizing

• Tabs keep VADs from sliding

## Magnetic VAD Holder

No more waiting for a special size – take an existing VAD and grind it to the size you need right on your valve refacer. Powerful magnets hold the VAD securely while you resize them. Tabs keep the VADs from sliding off the holder while grinding. Order No. **VDR-UNI** Jobber \$79.99 Replacement Magnet **VDR-MAG** Jobber \$5.99

## Resize VADs at your shop quickly and easily

**tech tips**  
from the techxperts™

Has this happened to you? You're adjusting the clearance between the valve stem and the cams and the stock Valve Adjustment Disc (VAD) isn't the right thickness. You need a 2.25 in a 28mm diameter and the thinnest ones available are 2.50. What are you going to do?

You could wait to have them resized by your supplier, but hey, you're a machinist! You have all of the tools and abilities right in your shop to modify the VADs you have into the VADs you need.

Place the VAD that you need to resize on your Magnetic VAD Holder (VDR-UNI, above). The powerful earth magnets will hold it securely. Using your Valve Grinder's stem end wheel, grind the VAD to the thickness you need. You're now ready to install it in the head. All in a few minutes instead of a few days.

## VAD Adjusting Tools For Toyota



- Reach around the cam to depress the lifter
- Wedge holds the lifter down to free the Valve Adjustment Disc
- Reach in to remove and replace the disc
- For most models prior to 2004

Description	Jobber	Order No.
Pliers and Wedge	\$39.99	VBT-40
Wedge only	14.99	VDL-20



## Smog Plugs

- Replace smog plugs damaged during head cleaning process

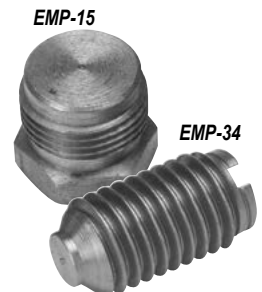

Application	Thread	Jobber	Order No.
Chevy 2.5L, 4.1L	3/4" x 18	\$2.49	EMP-15
Ford 302, 351	5/8" x 11 (outside), 7/16" x 14 (inside)	4.49	EMP-34

CYLINDER HEAD  
REBUILDING

CLEANING,  
ASSEMBLY & SAFETY

SHORT BLOCK  
REBUILDING

FLYWHEEL GRINDING

CRANKSHAFT/  
MISCELLANEOUS

TOOLS & SUPPLIES  
CHANGING TOOLS

MEASURING  
TOOLS

BRAKE & TIRE  
V-TWIN & METRIC  
HARD PARTS



"When you call Goodson, you speak to a person, not a machine. We work hard to make sure we answer your calls promptly and avoid keeping you on hold."

—Katie, Goodson Afternoon Receptionist, 2 years of service

CYLINDER HEAD  
REBUILDING

CLEANING,  
ASSEMBLY & SAFETY

SHORT BLOCK  
REBUILDING

CRANKSHAFT/  
FLYWHEEL GRINDING

MISCELLANEOUS  
TOOLS & SUPPLIES

BRAKE & TIRE  
CHANGING TOOLS

MEASURING  
TOOLS

V-TWIN & METRIC  
HARD PARTS

## Manual Rocker Arm Stud Puller

- Heavy-duty ball bearing action
- Creates less stress and friction
- Fits 5/16" (7.9mm) and 3/8" (9.53mm) threaded studs
- Not recommended for use on thermally cleaned heads

Description	Jobber	Order No.
Complete Stud Puller	\$119.99	SP-600
Drive Nut	23.99	SP-601
Puller Body	49.99	SP-602
5/16" and 3/8" Mandrel	49.99	SP-603
Thrust Bearing	11.99	SP-604

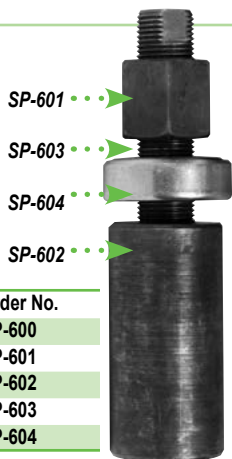

## Rocker Arm Stud Conversion Kit

- Convert pressed-in rocker arm studs to threaded studs
- Remove stud, face stud boss, then drill and tap the stud hole
- Use with a seat and guide machine

Description	Jobber	Order No.	Incl.
Conversion Kit	\$139.99	S-450-KIT	▼
Stud Boss Facer	124.99	S-450-F	x
3/8" Drill Bit	11.79	S-373D	x
7/16" x 14 Thread Tap	19.99	S-437T	x
3/8" Pilot	20.99	S-373P	x
2 Pc. SB V8 Chevy Tap Guide	39.99	S-350G	



## Universal Threaded Stud Extractor

- Use with your pneumatic impact tools & sockets (1 5/16" socket removes, 1 7/16" installs)
- Requires only 3/4" clearance to adjacent studs
- For threaded studs only
- Hardened 3-jaw clamping system
- Internal taper support
- Hollow body allows long studs to extend through the tool
- 1 1/2" dia. x 2 7/8" long • 1/4" - 1/2" range

Description	Jobber	Order No.
Universal Stud Extractor	\$149.99	PSR-500
Replacement Parts	104.99	PSR-JAWS
Spring Set	5.99	PSR-3S
Snap Ring	3.99	PSR-SR



## Torque-Angle Indicator

- When torque is given as degrees of turn past a certain ft./lb., use this gauge to show degrees
- Hold metal base with one hand
- Plastic dial turns as you tighten
- Fits between a socket-driven extension and the socket
- 1/2" square drive
- Order No. **TQR-4554**  
Jobber \$19.99



## Chevy Conversion Plate Set

- Convert early model, 6-bolt heads for late model, 7-bolt applications
- Works with stock exhaust systems
- Use the standard exhaust manifold gasket or seal with High-Temp Silicone
- Order No. **CHC-10** Jobber \$26.99

Buy 6 or more cans of Cutting & Tapping Fluid and SAVE 10% off Jobber



## Cut through even the hardest metals with Cutting & Tapping Fluid

- Spray clings to the surface of the tool to prolong tool life • Ideal for stainless steel, high nickel alloys, titanium and more
- Use for reaming, seat cutting and CBN cutting
- Aerosol\* • Order No. **CTF-14** Jobber \$12.49



\*Hazardous Goods Fees Apply When Shipped by Air

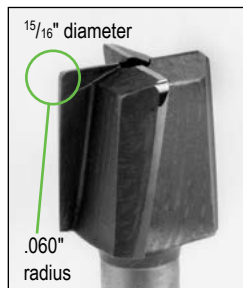

## Head Bolt Spot Facer

- Spot face head bolt seat parallel to new deck surface after angle milling
- Allows proper head bolt torquing
- Cutting tip radius matches OE design to avoid stress points and cracks
- .468" shank with flat

Description	Jobber	Order No.
Spot Facer	\$99.99	HBF-15
1/16" Pilot	14.99	GFP-437

## Two Blade Spot Facer

- 1 1/4" OD Spot Facer located on 3/8" stud
- Removes unneeded material for easier removal and installation of screw-in studs
- Replaceable carbide blades

Description	Jobber	Order No.	Incl.
Stud Boss Facer	\$129.99	SBF-5587	▼
Stud Boss Facer Tip (each) for SBF-5587 only	19.99	SBF-5587T	x
Stud Boss Facer Screw (each)	5.99	SBF-5587S	x
Replacement Stud Boss Facer 3/8" Pilot (optional)	27.99	SBF-5587P	



More Stud Boss Facers on page 34

# Head Holders and Stands

## American Made

### Economy Cylinder Head Holder

- Holds head with either side up
- Tapered pins fit any size head bolt hole and loosen with a twist
- Ideal for guide sizing with ample clearance to remove arbors and reamers
- All steel construction
- Two piece set
- Order No. **HH-100-G** Jobber \$27.99

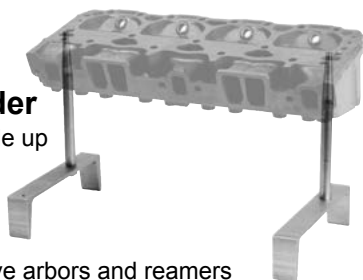

### Ultra-Sturdy Cylinder Head Holder

- 360° stand holds head securely in position
- Tie-rod to prevent tipping
- Slip-resistant neoprene covered rails
- Fits domestic, foreign, truck & motorcycle heads
- 3-piece set
- Order No. **HH-450** Jobber \$99.99

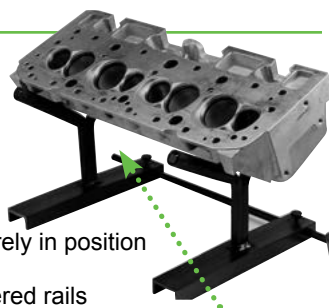

Set screws hold the two pieces firmly in place

### Universal Cylinder Head Holder

- Accommodates all types of cylinder heads
- Sturdy, durable, lightweight aluminum construction
- Slip-resistant neoprene covered rails
- Place heads quickly into any position and rotate them easily through 360°
- Requires no bolts, clamps or adaptors
- 2 piece set • Order No. **HH-200** Jobber \$129.99

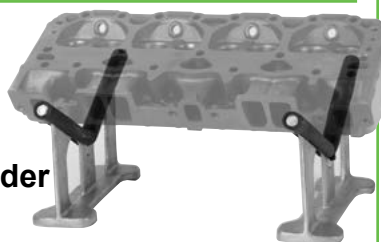

### Professional Measuring & Inspection Stand

- Length adjusts up to 23"
- Rotate work to view or measure
- Solid aluminum frame with self lubricating, corrosion and chemical-resistant wear surfaces
- Order No. **PMIS-30** Jobber \$124.99

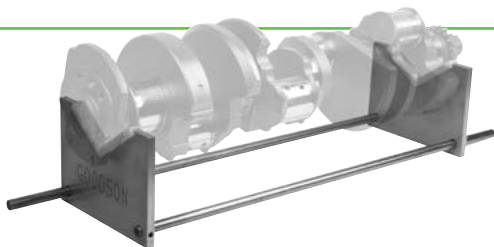

new design



### Steel Double Harley Head Plate

This Double Head Plate is designed to accommodate two heads at the same time. Its unique design gives perfect alignment of the centerline of valve guides, providing repeatable accuracy from head to head. The plate is heavy enough for cutting and installing guides and seats. It is designed to be used on a seat and guide machine or Bridgeport-type Mill, including CNC machines. Measures 10" x 22" x 1" thick and includes 3/8" dowel pins. Blackened steel construction. Order No. **HHP-23** Jobber \$749.99

Goodson exclusive

evolution twin cam sportster

### V-Twin Decking Jig

- Mount V-Twin heads to your mill quickly, easily and accurately
- Solid steel construction
- Includes Socket-Head Cap Mounting Screws
- Measures 3" x 5 1/2" x 1 1/4"
- Order No. **HDF-113** Jobber \$99.99

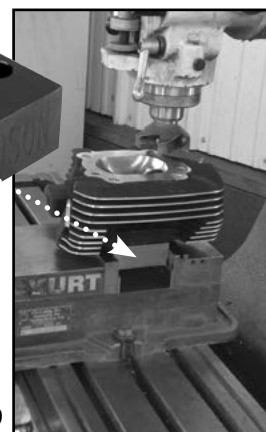
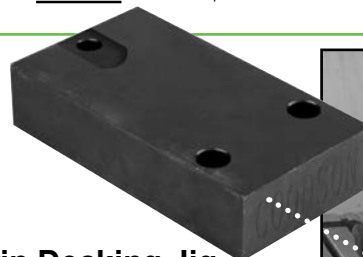

CYLINDER HEAD REBUILDING  
CLEANING, ASSEMBLY & SAFETY  
SHORT BLOCK REBUILDING  
CRANKSHAFT/ FLYWHEEL GRINDING  
MISCELLANEOUS TOOLS & SUPPLIES  
CHANGING TOOLS  
BRAKE & TIRE  
MEASURING TOOLS  
V-TWIN & METRIC HARD PARTS

# servicio completo rápido



"Hablamos español. Para su conveniencia tenemos representantes bilingües que le puedan ayudar con su orden." - Veronica, Ventas y Servicio, 2 años de servicio

CYLINDER HEAD REBUILDING  
CLEANING, ASSEMBLY & SAFETY  
SHORT BLOCK REBUILDING  
CRANKSHAFT/ FLYWHEEL GRINDING  
MISCELLANEOUS TOOLS & SUPPLIES  
BRAKE & TIRE CHANGING TOOLS  
MEASURING TOOLS  
V-TWIN & METRIC HARD PARTS

## Aluminum Oxide Cloth Utility Shop Rolls

- 1" x 50 yards
- Easy to use ... just unroll and tear to length
- Use with butterfly mandrels at right

Grit	Jobber	Order No.
60	\$20.99	UR-1-60
80	23.29	UR-1-80
100	20.99	UR-1-100
120	20.99	UR-1-120
180	20.99	UR-1-180
320	20.99	UR-1-320



## Crocus Cloth

- Must be used with Lapping Oil
- Great for final touch-ups on cranks, rod pins, valve stems, cams, etc.
- Use with slotted mandrels at right

Description	Jobber	Order No.
1" x 50 yd. Roll	\$38.99	UR-1-CROCUS
4 oz. Lapping Oil	10.49	LP-LO-4
8 oz. Lapping Oil	17.99	LP-LO-8



## Slotted Butterfly Mandrels

- Use with roll abrasives such as those at left • Several lengths available

Length	Jobber	Order No.
3"	\$ 5.29	BM-3
6"	9.99	BM-6
8"	10.99	BM-8
10"	13.79	BM-10
12"	16.79	BM-12



# Replacement Abrasive Packs and Mandrels

### Abrasive Grinding Discs (Quick Change)

Box of 50

Dia.	Grit	Jobber	Order No.
1½"	80	\$26.29	AGD-15-80
2"	80	25.29	AGD-2-80



### Replaceable Roll Lock Discs

10 per pack.

Dia.	Jobber	Order No.
2" Medium	\$10.49	RSCD-2M
Coarse	12.99	RSCD-2C
3" Medium	16.79	RSCD-3M
Coarse	20.99	RSCD-3C

Disc Holder	Jobber	Order No.
2" Dia.	\$14.99	RLH-2
3" Dia.	16.99	RLH-3

### Straight Cartridge Rolls

- 1½" long, ⅛" hole
- Fully glued • Box of 50

Dia.	Grit	Jobber	Order No.
¼"	40	\$24.29	SCR-250-40
80	24.29	SCR-250-80	
120	24.29	SCR-250-120	
¾"	40	24.29	SCR-375-40
80	24.29	SCR-375-80	
120	24.29	SCR-375-120	
320	24.29	SCR-375-320	
½"	40	29.49	SCR-500-40
60	29.49	SCR-500-60	
80	29.49	SCR-500-80	
100	29.49	SCR-500-100	
120	29.49	SCR-500-120	
¾"	40	57.79	SCR-750-40
80	57.79	SCR-750-80	
120	57.79	SCR-750-120	

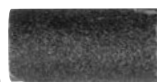

### Straight Cartridge Rolls

- 1" long, ⅛" hole
- Fully glued • Box of 50

Dia.	Grit	Jobber	Order No.
¼"	60	\$18.99	SCR-1-250-60
80	16.79	SCR-1-250-80	

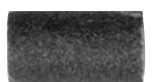

### Half-Tapered Cartridge Rolls

- 1½" long, ⅛" hole
- Fully glued • Box of 50

Dia.	Grit	Jobber	Order No.
¾"	40	\$36.79	HTR-375-40
80	37.79	HTR-375-80	
120	39.99	HTR-375-120	
320	39.99	HTR-375-320	
½"	40	39.99	HTR-500-40
80	39.99	HTR-500-80	

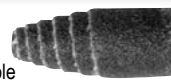

### Full-Tapered Cartridge Rolls

- 1½" long, ⅛" hole
- Fully glued • Box of 50

Dia.	Grit	Jobber	Order No.
¾"	40	\$26.29	FTR-375-40
80	27.79	FTR-375-80	
120	27.79	FTR-375-120	
320	29.49	FTR-375-320	
½"	40	31.49	FTR-500-40
60	29.49	FTR-500-60	
80	30.49	FTR-500-80	
100	41.99	FTR-500-100	
120	30.99	FTR-500-120	
5/8"	40	41.99	FTR-625-40
80	41.99	FTR-625-80	



### Cross Buffs®

Box of 10

Dia.	Grit	Jobber	Order No.
<b>2-Ply</b>			
¾"	V. Fine	\$31.49	CB-75VF
	Med.	31.49	CB-75M
1"	V. Fine	31.49	CB-1VF
	Med.	31.49	CB-1M
1½"	V. Fine	31.49	CB-15VF
	Med.	31.49	CB-15M
<b>3-Ply</b>			
1¼"	V. Fine	\$41.99	CB-125VF-HD
	Med.	41.99	CB-125M-HD
1½"	V. Fine	41.99	CB-15VF-HD
	Med.	41.99	CB-15M-HD

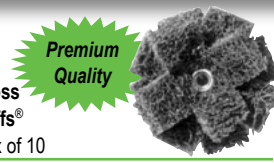

### Cross Buff® / Flap Wheel Mandrel

Description	Jobber	Order No.
4" Mandrel	\$11.99	CB-MANDREL
Set Screw (3)	5.99	CB-SCREW



### Abrasive Flapwheels

1" wide, ¼" x 20 threaded. 1 each.

Dia.	Grit	Jobber	Order No.
1½"	80	\$11.99	APK-7
2"	80	11.99	APK-8
2½"	80	11.99	APK-9
1"	120	7.99	AFW-1-120
2"	120	8.99	AFW-2-120
3"	120	9.99	AFW-3-120

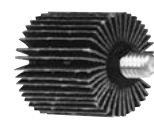

## Aluminum Machining Aid

- Designed for aluminum
- For porting & polishing with cartridge rolls, rotary files, emery cloth or Cross Buffs®
- Safe for cast iron
- 32 oz./946.4mL
- Order No. **PF-32** Jobber \$41.99



### Roll Mandrels

Use with straight and tapered cartridge rolls • ⅝" pilot x ¼" dia.

Length	Jobber	Order No.
2¾"	\$ 8.79	CR-275
4"	9.79	CR-40
6"	10.99	CR-60
8"	13.29	CRM-8H
10"	13.29	CRM-10H
12"	13.29	CRM-12H



## Mirrored Safety Glasses

- Wrap-around design
- Tinted lenses provide sun glare protection • Universal bridge • Polycarbonate lenses • Do not use as welders helpers
- Order No. **PGL-21** Jobber \$4.99



NOTE: Extreme caution must be used when porting & polishing. Be sure to wear safety glasses.

# Professional Porting & Polishing Tools



## 48 Piece Deluxe Porting Kit

- Professional grade porting supplies
- Packed in a clear plastic storage case

Description	Jobber	Order No.	Incl.
48 Pc. Kit	\$94.49	DPK-100	▼
<b>Replacement Abrasives</b>	<b>Grit Kit Qty. Repl. Qty.</b>		
Flap Wheels - 1"x1"x1/4"	120 4 5 \$39.99	APK-4	x
Cross Buffs 2 Ply, 1 1/2"	Med. 2 10 31.49	CB-15M	x
	Very Fine 2 10 31.49	CB-15VF	x
Cross Buff/Flapwheel Mandrel	1 1 11.99	CB-MANDREL	x
1/4" Dia. Straight	40 2 50 24.29	SCR-250-40	x
Cartridge Rolls	80 5 50 24.29	SCR-250-80	x
3/8" Dia. Straight	40 2 50 24.29	SCR-375-40	x
Cartridge Rolls	80 5 50 24.29	SCR-375-80	x
3/4" Dia. Straight	40 2 50 57.79	SCR-750-40	x
Cartridge Rolls	80 2 50 57.79	SCR-750-80	x
1/2" Half Tapered	40 2 50 36.79	HTR-375-40	x
Cartridge Rolls	80 5 50 37.79	HTR-375-80	x
3/8" Full Tapered	40 2 50 41.99	FTR-625-40	x
Cartridge Rolls	80 5 50 41.99	FTR-625-80	x
Cartridge Roll Mandrel	2 3/4" Long 1 1 8.79	CR-275	x
	4" Long 1 1 9.79	CR-40	x
Mounted Points - 3/8" x 3/4"	60 1 1 7.99	GM-B52	x
	1 1/16" x 1 1/4" 60 1 1 7.99	GM-12	x

small engine  
powersports



## 44 Piece Small Engine Porting Kit

- Professional grade porting supplies
- Packed in a clear plastic storage case

Description	Jobber	Order No.	Incl.
48 Pc. Kit	\$65.29	SEPK-5	▼
<b>Replacement Abrasives</b>	<b>Grit Kit Qty. Repl. Qty.</b>		
Flap Wheels - 1"x1"x1/4"	120 2 1 \$ 7.99	AFW-1-120	x
Cross Buffs 2 Ply 3/4"	Very Fine 2 10 31.49	CB-75VF	x
	1" Medium 2 10 31.49	CB-1M	x
	Very Fine 2 10 31.49	CB-1VF	x
	1 1/2" Very Fine 2 10 31.49	CB-15VF	x
Cross Buff/Flapwheel Mandrel	1 1 11.99	CB-MANDREL	x
3/8" Dia. Straight	80 4 50 24.29	SCR-375-80	x
Cartridge Rolls	120 4 50 24.29	SCR-375-120	x
	320 4 50 24.29	SCR-375-320	x
3/8" Half Tapered Cartridge Rolls	80 4 50 37.79	HTR-375-80	x
3/8" Full Tapered	80 4 50 27.79	FTR-375-80	x
Cartridge Rolls	120 4 50 27.79	FTR-375-120	x
1" x 2 Yds. Abrasive Roll	120 1 1 20.99	UR-1-120	x
	320 1 1 20.99	UR-1-320	x
Cartridge Roll Mandrel	2 3/4" Long 1 1 8.79	CR-275	x
	4" Long 1 1 9.79	CR-40	x

## Silicon-Carbide Abrasive Rolls with Integral 4" Mandrels

- 4" integral mandrel and solid abrasive core allows you to use up the entire roll before replacing it
- Available in 1/2" and 5/8" diameters • 5 per pack

Dia.	Grit	Jobber	Order No.	Dia.	Grit	Jobber	Order No.
1/2"	60	\$26.29	LSCR-500-60	5/8"	60	\$26.29	LSCR-625-60
	80	29.49	LSCR-500-80		80	29.49	LSCR-625-80

## Quick Change Mandrels & Abrasive Sleeves

- 5 sleeves per pack • 1" x 1"
- Mandrel has 1/4" shaft

Description	Grit	Jobber	Order No.
Mandrel		\$8.99	GMS-101
Sleeves	40	8.99	GMS-140
	60	8.99	GMS-160

## Intake Port Reshaping Kit

- Superior formula uses 2-part epoxy • Won't shrink when dry • Can be milled or machined • Withstands temperatures up to 500°F/260°C • Kit includes epoxy, gloves and mixing sticks
- Yields 16 oz./453.6g of material
- Order No. **PRK-99** Jobber \$36.99



**tech tips**  
from the techxperts™  
*Epoxy components are the consistency of a thick paste and must be kneaded together.*



## 110V Electric Die Grinder

- 1/4" collet • 8' cord • 110V • 2.5 amp • 25,000 RPM
- Includes 2 collet wrenches
- Optional Speed Control lets you vary from 200 to 25,000 RPM • 6' cord • 110V • 15 amp

Description	Jobber	Order No.
25,000 RPM Die Grinder	\$219.99	GEO-600
Variable Speed Control	44.99	GEO-SC



**NOTE: Extreme caution must be used when porting & polishing. Be sure to wear safety glasses.**

CYLINDER HEAD REBUILDING  
CLEANING, ASSEMBLY & SAFETY  
SHORT BLOCK REBUILDING  
FLYWHEEL GRINDING  
CRANKSHAFT/ MISCELLANEOUS  
BRAKE & TIRE  
MEASURING TOOLS  
V-TWIN & METRIC HARD PARTS

... another satisfied customer

"When rebuilding several motors at a time, your organizer trays are very important. We love the thought given in the products and how parts remain in important order!"

- George Bernacchi, BB Tire Shop, via Facebook

CYLINDER HEAD REBUILDING

CLEANING, ASSEMBLY & SAFETY

SHORT BLOCK REBUILDING

CRANKSHAFT/ FLYWHEEL GRINDING

MISCELLANEOUS TOOLS & SUPPLIES

BRAKE & TIRE CHANGING TOOLS

MEASURING TOOLS

V-TWIN & METRIC HARD PARTS

## tech tips

from the techxperts™

### Stay Safe:

Always ensure your burr shank is well inserted into your collet and clamped down tightly

Keep pressure light and keep the burr moving focusing on the highest material first

Ensure your work is secured tightly to your work bench

Don't snag or jam your burr into your work

Wear eye protection as a minimum but better still use a full shield for your face

FR-34-C



FR-45-C



## 1/4" Shank Carbide Rotary Double Cut Files

Dia.	Length	Shank	Jobber	Order No.
1/2"	1 1/8"	1.1"	\$39.99	FR-34-C
1/4"	1"	1.0"	34.99	FR-45-C

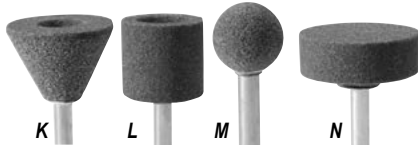
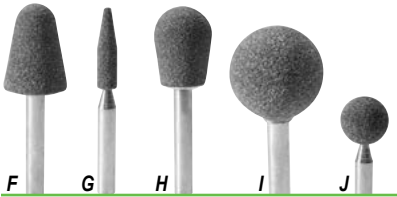
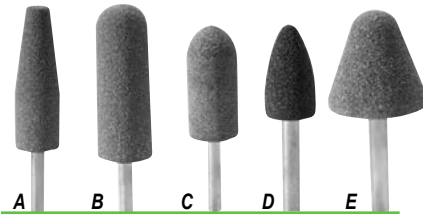

## 1/4" Shank Mounted Points

• Aluminum-Oxide abrasive is ideal for roughing cast iron • 1 1/2" shank length

Dia.	Length	Grit	Jobber	Order No.
A 3/4"	2 1/2"	60	\$7.99	GM-1
B 7/8"	2 3/4"	60	7.99	GM-3
C 7/8"	1"	60	7.99	GM-11
D 1 1/16"	1 1/4"	60	7.99	GM-12
E 1 1/4"	1 1/4"	60	7.99	GM-4
F 3/4"	1 1/8"	60	7.99	GM-5
G 1/4"	1 1/16"	60	7.99	GM-15
H 3/4"	1"	60	7.99	GM-23
I 1"	1"	60	7.99	GM-25
J 5/8"	5/8"	60	7.99	GM-26
K 1 3/8"	1"	60	7.99	GM-31
L 1"	1"	60	7.99	GM-38
M 3/4"	3/4"	40	7.99	GM-40
N 1 1/2"	1 1/16"	60	7.99	GM-236

## Short Long

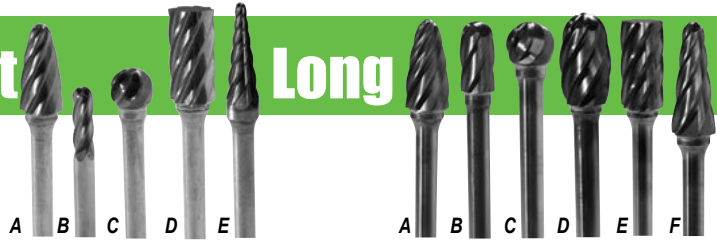

## Open Fluted Rotary Files for Aluminum

Choose between 2 shank lengths – 1 1/2" and 6" in several sizes. All of the files feature a 1/4" diameter shank

Dia.	Length	Jobber	Order No.
A 1/2"	1"	49.99	AFR-34
B 1/4"	1 5/16"	49.99	AFR-45
C 1/2"	1/2"	49.99	AFR-55
D 1/2"	1"	49.99	AFR-93
E 3/8"	1 3/16"	49.99	AFR-121

Dia.	Length	Jobber	Order No.
A 1/2"	1"	64.99	LAFR-34
B 3/8"	3/4"	39.99	LAFR-45
C 1/2"	7/16"	57.99	LAFR-55
D 1/2"	7/8"	59.99	LAFR-70
E 1/2"	1"	59.99	LAFR-93
F 3/8"	1 1/16"	79.99	LAFR-121

Save almost 30% when you buy the kit!

## 6" Long Shank Double Cut Carbide Rotary Files

• 1/4" diameter shank

Dia.	Length	Jobber	Order No.	Incl.
Complete 5 Pc. Kit		\$199.99	LFR-KIT	▼
A 1/2"	1 1/8"	49.99	LFR-34C	x
B 1/4"	1/2"	49.99	LFR-45C	x
C 1/2"	1/2"	49.99	LFR-55C	x
D 1/2"	1 1/16"	49.99	LFR-46C	x
E 1/2"	1 3/8"	49.99	LFR-141C	x



## Carbide Single Cut Rotary Files for Aluminum

- 1/8" heat treated steel shanks
- For all non-ferrous metals
- 1 1/2" shank length (nominal)

Order 5 or more Rotary Files, Burrs or Mounted Points (mix & match) and save 10% off jobber



Dia.	Cut Length	Jobber	Order No.
1/4"	1/2"	\$16.99	FRA-51F
1/4"	1/2"	16.99	FRA-51C
1/4"	1/2"	16.99	FRA-51A
1/4"	1/4"	16.99	FRA-51E

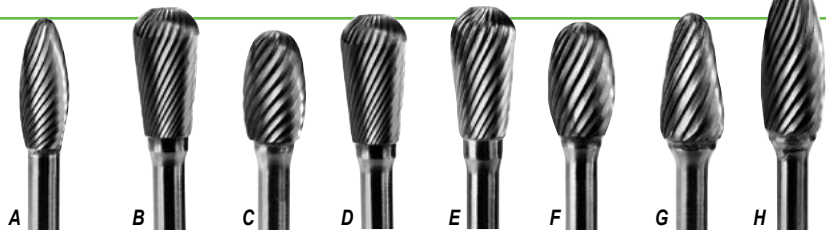
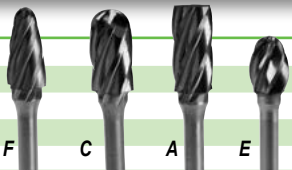

## 1/4" Carbide Rotary Files

- Nose design reduces back-gouging
- 1/4" shank • Shanks 4" long except MRT-56C at 6" long



Dia.	Lgth.	Jobber	Order No.
A .375"	1.000"	\$44.99	MSH-34C
B .437"	.970"	57.99	MRT-44C
C .437"	.875"	47.99	MSE-44C
D .500"	.975"	57.99	MRT-54C

Dia.	Lgth.	Jobber	Order No.
E .500"	1.000"	\$57.99	MRT-56C
F .500"	.880"	47.99	MSE-54C
G .500"	1.000"	44.99	MSE-54C
H .500"	1.245"	49.99	MSH-54C

# Parts Organization

## Dual Overhead Cam Cylinder Head Organizer Tray

- Store valves, springs, retainers, keepers, valve lash adjusters & camshafts
- Keep valve lash adjusters from getting mixed up and changing the valve adjustment
- Virtually unbreakable
- Oil and solvent resistant
- 23¼" x 26½" x 2"
- Order No. **DOHC-1** Jobber \$47.29

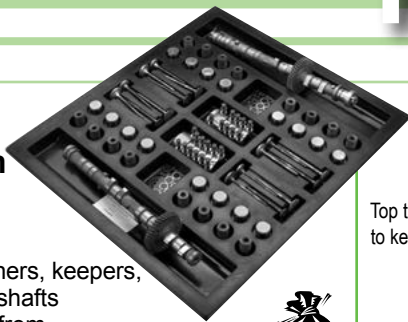

### Parts Trays

Order 4-9 get 10% off jobber, 10 or more get 20% off jobber. Mix or match trays to make quantities.



## Stackable Cylinder Head Organizer Trays

- Store valves, springs, retainers and keepers in order of assembly • Impervious to oil and most solvents
- Measures 28" x 12½" x 3"H
- Order No. **SHO-8** Jobber \$54.99

## Valve Train Tray For 4, 6 or 8-Cylinder OHV Engines

- Heavy duty construction
- Keeps push rods, rockers, lifters, etc. in order
- Unbreakable
- 64 compartments
- Measures 11½"W x 13½"D x 1½" H
- Order No. **VTO-80** Jobber \$46.99



Top tray features 1" deep lip to keep parts from rolling off

Solid steel hangers hold piston rods and crankshafts. Heavy duty casters make moving the engine and cart easy.

## Engine Storage Cart

- An efficient space-saver
- Heavy-duty casters
- Holds all engine parts off the floor from tear-down to reassembly in less than 4 square feet
- Move the whole engine easily
- Some assembly required
- Order No. **EC-200** Jobber \$379.99

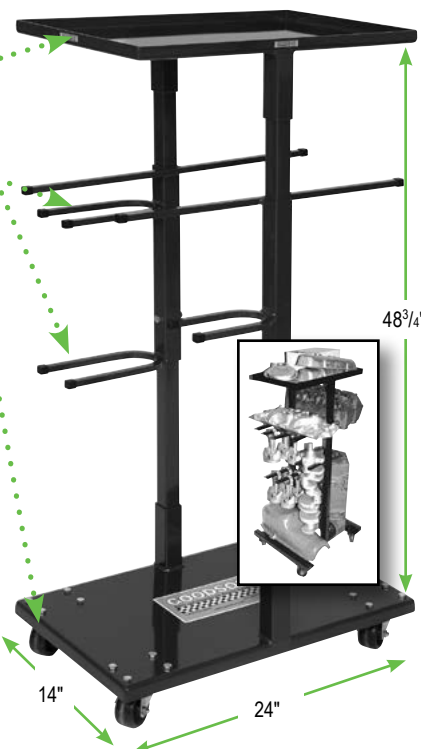

## Ford/Chevy Small Block Organizer Tray

- Store pistons, rods, lifters, push rods & camshafts
- Formed compartments keep engine components securely in place
- Measures: 24¼" x 25½" x 1½"D
- Order No. **iEO-80** Jobber \$31.79

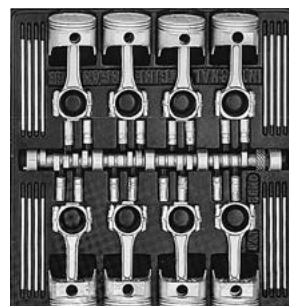

## Bifocal Magnifying Safety Glasses

Diopter	Jobber	Order No.	Diopter	Jobber	Order No.
1.00	\$16.99	<b>BSG-100</b>	2.00	\$16.99	<b>BSG-200</b>
1.25	16.99	<b>BSG-125</b>	2.25	16.99	<b>BSG-225</b>
1.50	16.99	<b>BSG-150</b>	2.50	16.99	<b>BSG-250</b>
1.75	16.99	<b>BSG-175</b>	3.00	16.99	<b>BSG-300</b>



## Harley® Head Organizer Tray

- Virtually unbreakable molded plastic • Oil and solvent resistant • Trays stack for easy storage
- Measures 27⅞" x 14⅞" x 3"
- Order No. **HHO-2** Jobber \$29.99

Quantity Discount Does Not Apply

CYLINDER HEAD REBUILDING  
CLEANING, ASSEMBLY & SAFETY  
SHORT BLOCK REBUILDING  
CRANKSHAFT/ FLYWHEEL GRINDING  
MISCELLANEOUS TOOLS & SUPPLIES  
BRAKE & TIRE CHANGING TOOLS  
MEASURING TOOLS  
V-TWIN & METRIC HARD PARTS



### End Brushes

Dia. / Wire gauge / Type	Jobber	Order No.
<b>Standard Duty</b>		
1/2" .020" crimped	\$ 7.99	<b>GBC-4</b>
3/4" .020" crimped	9.79	<b>GBC-6</b>
1" .020" crimped	11.79	<b>GBC-10</b>
1 1/2" .020" crimped	9.99	<b>GBC-14</b>
1 3/4" .012" crimped	11.79	<b>NH-16</b>
2 3/4" .012" crimped	14.99	<b>NH-26</b>
1 3/4" .014" galv. for alum.	9.99	<b>ANH-16</b>
2 3/4" .014" galv. for alum.	9.99	<b>ANH-26</b>
<b>Ultra Duty (listed left to right)</b>		
1/2" .014" crimped	\$ 7.99	<b>GBC-4A</b>
1 1/8" .020" knotted	13.99	<b>GBC-12</b>
1 1/8" .020" knotted	14.99	<b>GBC-12HD</b>
3/4" .020" knotted	10.99	<b>NH-6</b>

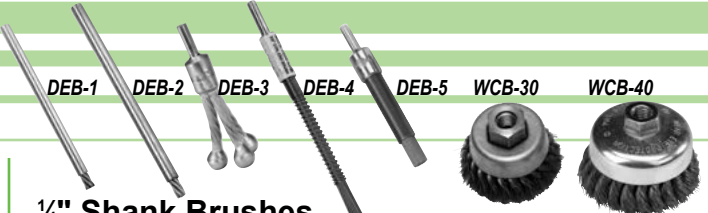

### 1/4" Shank Brushes

Deep Well End Brush as brush wears cut back to expose new wire				
Dia.	Wire Gauge	Grade	Jobber	Order No.
1/4"	.012", 6" long	Economy	\$11.79	<b>DEB-1</b>
3/8"	.017", 6" long	Economy	15.79	<b>DEB-2</b>
<b>Flare Brush</b> use to remove carbon from engine ports				
1/2" ball, 5/16" cable		Ultra-duty	\$47.29	<b>DEB-3</b>
<b>Port Brush</b> as brush wears cut back spring for new wire				
1/4"	.014", 4" long	Standard	\$20.99	<b>DEB-4</b>
1/2"	.020", 2 1/2" long	Ultra-duty	20.99	<b>DEB-5</b>
<b>Cup Brush</b> 5/16"-11 NC - fits standard 4 1/2" angle grinder				
3"	.014" twisted	Ultra-duty	\$24.99	<b>WCB-30</b>
4"	.014" twisted	Ultra-duty	32.79	<b>WCB-40</b>

### Engine Prep Brushes

Application	Jobber	Order No.
For small feed hole in block 1/4" x 2" x 10", nylon	\$5.49	<b>OB-1</b>
For Block Oil Return Line 5/16" x 2 1/2" x 12", nylon	5.49	<b>OB-2</b>
Like OB-2 but more flexible 5/16" x 2 1/2" x 12", nylon	5.49	<b>OB-2A</b>
For Block Oil Return Lines 3/8" x 2 1/2" x 12", nylon	5.49	<b>OB-3</b>
For diesel injector 1 3/4" brush, stainless	7.99	<b>DIB-1</b>
For lifter bores 1" x 3" x 14", nylon	8.49	<b>LBB-100</b>



### Manual Guide Cleaning Brush

- 1/2" Diameter
- Nylon bristles
- OAL: 8 3/4"
- Order No. **WCB-44**
- Jobber \$3.29

**Order 5 or more brushes, (any combination) take 10% off jobber, 15 or more brushes, (any combination) 15% off jobber**

### Round Fiber Parts Brush

- 11" long
- Nylon bristles
- Plastic Handle
- Order No. **PCB-348**
- Jobber \$7.99



### Nylon Bristle Oil Gallery Brushes

Desc.	Jobber	Order No.
<b>5-pc. Kit</b>	\$27.99	<b>OGB-KIT</b> ▼
3/8" x 3" x 34"	6.49	<b>OGB-38</b> x
1/2" x 2 1/2" x 34"	6.79	<b>OGB-42</b> x
5/8" x 3" x 34"	6.79	<b>OGB-5</b> x
3/4" x 3" x 34"	7.49	<b>OGB-7</b> x
5/8" x 3" x 24"	9.49	<b>OGB-3</b> x

Desc.	Jobber	Order No.
<b>3-pc. Kit</b>	\$16.99	<b>OGB-SK</b> ▼
1/4" x 3" x 24"	7.49	<b>OGB-1</b> x
3/8" x 3" x 24"	8.49	<b>OGB-2</b> x
5/8" x 3" x 24"	9.49	<b>OGB-3</b> x

### Steel Wire Oil Gallery Brushes

Bore Washing Brushes			
Dia.	Length	Jobber	Order No.
2"	36"	\$18.99	<b>CBB-200</b>
2 1/4"	36"	19.99	<b>CBB-225</b>
2 1/2"	36"	20.99	<b>CBB-250</b>
2 3/4"	18 1/2"	23.29	<b>CWB-27W</b>
3 1/2"	18 1/2"	23.29	<b>CWB-35</b>
4"	18 1/2"	23.29	<b>CWB-40</b>
4 1/2"	18 1/2"	24.29	<b>CWB-45</b>
5"	18 1/2"	25.29	<b>CWB-50</b>

### Flow Through Parts Washing Brush

- 24" long hose slides over discharge nozzle on parts washer
- Order No. **PWB-FLO-1**
- Jobber \$24.99



### Pushrod Brush

- Clean the inside diameter of your pushrods with this brush
- Will fit pushrods as small as .080" ID
- 12" overall length
- Order No. **PRB-80**
- Jobber \$12.99

**tech tips**  
from the techxperts™

It's important to clean the insides of your pushrods when rebuilding an engine. Not cleaning the ID of the pushrods is like putting your dirty clothes on after a bath; you risk contaminating all of the work you've done. You need the pushrod brush because the ID is so small it's unlikely that your hot tank will be able to get the gunk out.

### Valve Guide Brushes

Size	Steel Brushes		Nylon Brushes	
	OAL	Order No.	OAL	Order No.
5/16" x 2 1/2"	9 1/2"	<b>GVP-1</b>	12"	<b>GVP-1N</b>
1 1/2" x 2 1/2"	9 1/2"	<b>GVP-2</b>	12"	<b>GVP-2N</b>
3/8" x 2 1/2"	9 1/2"	<b>GVP-3</b>	12"	<b>GVP-3N</b>
7/16" x 2 1/2"	9 1/2"	<b>GVP-4</b>	12"	<b>GVP-4N</b>
1/2" x 2 1/2"	—	—	10 1/2"	<b>GVP-5N</b>
9/16" x 2 1/2"	—	—	10 1/2"	<b>GVP-6N</b>
3mm x 1 1/4"	8"	<b>GVP-7S</b>	8"	<b>GVP-7N</b>
4mm x 1 1/4"	8"	<b>GVP-8S</b>	8"	<b>GVP-8N</b>
5mm x 1 1/4"	8"	<b>GVP-9S</b>	8"	<b>GVP-9N</b>
6mm x 1 1/4"	8"	<b>GVP-10S</b>	8"	<b>GVP-10N</b>
7mm x 1 1/4"	8"	<b>GVP-11S</b>	8"	<b>GVP-11N</b>
Jobber		\$6.79 ea.		\$6.79 ea.



## Radial Wire Brushes

### Crimped ... Standard & Heavy-Duty

This shape is specially designed to flex, giving longer life. The crimp also lets wires nestle together to support one another for more aggressive cleaning.

### Twisted ... Super Duty

Tougher than crimped, strands are twisted  $\frac{2}{3}$  of the length for stiffness with flexible ends that stay tight in use. These brushes are designed to be used at higher RPMs.

### Knotted ... Ultra Duty

Strands are twisted full length for best stiffness and fastest cleaning. Knots have more strands to resist breakage and outlast typical knotted brushes by a wide margin.

Order 5 or more brushes, (any combination) take 10% off jobber, 15 or more brushes, (any combination) 15% off jobber



#### Radial Wire Brushes

- American made oil tempered high carbon steel wire
- High density for faster cleaning and longer life
- Excellent balance •  $\frac{1}{2}$ " -  $\frac{5}{8}$ " arbor

Size	Wire	Duty	Jobber	Order No.
6" x $\frac{13}{16}$ "	.014" Crimped	Std.	\$14.99	ADA-6
7" x $\frac{7}{8}$ "	.014" Crimped	Heavy	43.99	DA-7
6" x $\frac{9}{16}$ "	.016" Twisted	Super	21.99	TS-6
8" x $\frac{3}{4}$ "	.016" Twisted	Super	52.49	TS-8
6" x $\frac{7}{16}$ "	.023" Knotted	Ultra	23.99	QTC-6

Buy the Kit and **SAVE!**



### Engine Rebuild Brush Kit

- Includes the brushes you'll need for an average engine job
- A great starting place, then add more brushes as you need them • Replacement brushes available

Description	Jobber	Order No.
Standard Brush Kit - 10 Pc. Kit	\$52.99	BG-KIT ▼
4" Nylon Cylinder Washing Brush	23.29	CWB-40 x
$\frac{1}{2}$ " Nylon Valve Guide Brush	6.79	GVP-2N x
$\frac{3}{8}$ " Nylon Valve Guide Brush	6.79	GVP-3N x
Lifter Bore Brush	8.49	LBB-100 x
Small Nylon Feed Hole Brush	5.49	OB-1 x
Block Oil Return Line Brush	5.49	OB-2 x
$\frac{3}{8}$ " Oil Gallery Brush	6.49	OGB-38 x
$\frac{1}{2}$ " Oil Gallery Brush	6.79	OGB-42 x
$\frac{5}{8}$ " Oil Gallery Brush	6.79	OGB-5 x
Round Fiber Parts Brush	7.99	PCB-348 x

### Roloc Bristle Discs

- Effective on cast iron, yet safe for aluminum
- Abrasive grains embedded in plastic bristles that break down exposing new grain

#### Roloc Bristle Discs

Size	Color	Grit	Max. RPM	Jobber	Order No.
2"	Green	50	25,000	\$11.99	RBD-2G
	Yellow	80	25,000	11.99	RBD-2Y
	White	120	25,000	11.99	RBD-2W
3"	Green	50	18,000	18.79	RBD-3G
	Yellow	80	18,000	18.79	RBD-3Y

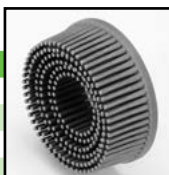

#### Holders

Size	Description	Jobber	Order No.
2"	Roloc-Type Holder	\$14.99	RLH-2
3"	Roloc-Type Holder	16.99	RLH-3

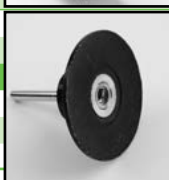

### Super Scraper™

- Remove gaskets, carbon, rust, paint, etc.
- Precision-ground
- Solid carbide-tipped
- Double-edged blade
- Lasts longer than plain steel
- Nickel-chrome •  $\frac{1}{8}$ " thick steel shank
- For all metals including aluminum



Width	Jobber	Order No.
$\frac{5}{8}$ "	\$24.99	SS-4U625
1 $\frac{1}{4}$ "	31.99	SS-4U
2"	42.99	SS-4U2

Buy one of each size and save 10% off jobber!



### Pneumatic Scraper

- Faster and easier than scraping by hand
- Beveled, 1" steel blade • Removes gaskets with 2500,  $\frac{3}{64}$ " strokes per minute • Resharpenable blade

Description	Jobber	Order No.
Complete Tool	\$99.99	AGS-310
Replacement Blade	15.79	AGS-310B

BG-150



BG-100

### Hydro-Air Guns

- Hold the BG-150 by the air supply hose
- The grip stays cool even when spraying
- hot water • BG-100 Trigger Action gun uses water and air pressure to deliver a powerful stream of "cold steam"
- BG-100 includes siphon tube, extension nozzle & flushing adaptor and connects to openings  $\frac{3}{4}$ " to  $\frac{1}{2}$ " in diameter

Description	Jobber	Order No.
Hydro-Air Gun	\$ 94.79	BG-150
Trigger-Action Hydro-Air Gun	139.99	BG-100
Replacement Nozzle for BG-100	27.99	BG-NOZZLE

CYLINDER HEAD REBUILDING  
CLEANING, ASSEMBLY & SAFETY  
SHORT BLOCK REBUILDING  
CRANKSHAFT/ FLYWHEEL GRINDING  
MISCELLANEOUS TOOLS & SUPPLIES  
BRAKE & TIRE CHANGING TOOLS  
MEASURING TOOLS  
V-TWIN & METRIC HARD PARTS



"We believe that every customer is important. If you need one of our tools or supplies overnight or have a last minute change on your order you can count on Goodson. You'll always receive the kind of courteous, personal attention that shows how much we appreciate you doing business with us."  
- Jarrad, Goodson Shipping Department, 2 years of service

CYLINDER HEAD REBUILDING  
CLEANING, ASSEMBLY & SAFETY  
SHORT BLOCK REBUILDING  
CRANKSHAFT/ FLYWHEEL GRINDING  
MISCELLANEOUS TOOLS & SUPPLIES  
BRAKE & TIRE CHANGING TOOLS  
MEASURING TOOLS  
V-TWIN & METRIC HARD PARTS

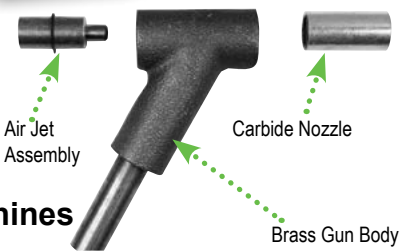

### Glass Bead Gun for Smaller Machines

- Solid brass body
- Fits Trinco, Econoline, etc.
- Includes Gun Body, Nozzle and Air Jet Assembly
- Replacement parts available

Description	Jobber	Order No.
<b>Complete Gun For Smaller Machines</b>	\$104.99	<b>GB-113</b>
<b>Replacement Parts</b>		
Gun body only	\$59.99	<b>GB-111</b>
Carbide nozzle 19.05mm OD, 7.94mm ID	48.99	<b>GB-204</b>
Air jet assembly 3.97mm ID, 25 CFM	19.99	<b>GB-330</b>

### Trigger-Control Glass Bead Gun



- Uses 9 CFM of compressed air
- Replacement gun
- Gun includes replaceable ceramic nozzle
- Nozzle diameter: 3/16" (4.76mm)
- For most economy bench-top glass bead cabinets
- Fits most cabinets with 1/2" (12.7mm) ID media supply line, threaded for 1/4" (6.35mm) air line fitting

Description	Jobber	Order No.
<b>Trigger-Control Glass Bead Gun</b>	\$99.99	<b>GB-9</b>
Replacement Nozzles (3 pack)	41.29	<b>GB-9-NOZ</b>

### Glass Beads

- Clean parts thoroughly without removing material
- 50 lb. bag • Size #8
- Safe for ferrous & non-ferrous materials
- Order No. **GB-CM**  
Jobber \$49.99

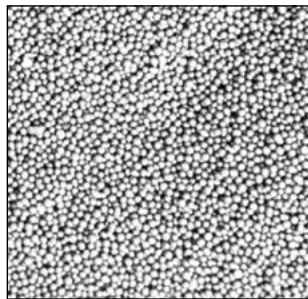

### Glass Bead Cabinet Window Film

- Protects the inside of glass bead cabinet windows
- Save time and money – replace the film rather than the glass • 24" x 10' roll
- Order No. **GB-FILM**  
Jobber \$18.99



**tech tips**  
from the techxperts™

For best results, attach film to cabinet window with ordinary double-faced tape (not included).

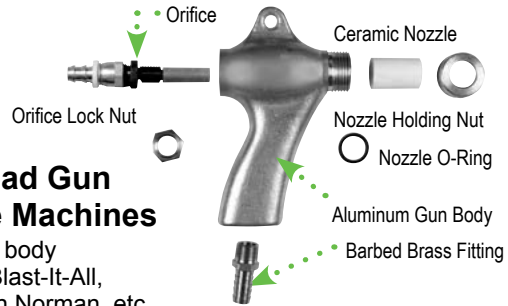

### Glass Bead Gun for Large Machines

- Solid brass body
- Fits Zero, Blast-It-All, Winona Van Norman, etc.
- Includes .313" ID ceramic nozzle

Description	Jobber	Order No.
<b>Complete Gun For Larger Machines</b>	\$139.99	<b>GB-100</b>
<b>Replacement Parts</b>		
Gun body only	\$83.49	<b>GB-101</b>
Barbed Brass fitting	8.49	<b>GB-04</b>
Nozzle holding nut (not included in kit)	14.99	<b>GB-54</b>

Rebuild Kits	Jobber	Order No.	Includes
.250" ID	\$59.99	<b>GB-4-OK</b>	▼
.313" ID	59.99	<b>GB-5-OK</b>	▼
.375" ID	59.99	<b>GB-6-OK</b>	▼
.437" ID	64.99	<b>GB-7-OK</b>	▼
<b>Ceramic Nozzles</b>			
.250" ID	22.99	<b>GB-74</b>	x
7/8" OD x 1 1/8"	22.99	<b>GB-75</b>	x
.375" ID	22.99	<b>GB-76</b>	x
.437" ID	27.99	<b>GB-77</b>	x
<b>Replacement Orifices</b>			
	44.99	<b>GB-64</b>	x
	44.99	<b>GB-65</b>	x
	44.99	<b>GB-66</b>	x
	44.99	<b>GB-67</b>	x
<b>Lock Nut</b>	8.79	<b>GB-52</b>	x x x x
<b>O-Ring</b>	6.49	<b>GB-53</b>	x x x x



### Glass Bead Gloves

- 30" overall length
- For ports up to 10" diameter
- Durable cloth-lined Neoprene glove with nylon sleeve
- Sleeve design makes attaching glove to your machine, faster and easier • Clamp sold separately

Port Size	Description	Jobber	Order No.
Up to 8" (20.32 cm)	Single: left-hand glove	\$37.99	<b>GB-654-G</b>
	Single: right-hand glove	37.99	<b>GB-655-G</b>
	Pair: one right-hand & one left-hand	62.99	<b>GB-660-G</b>
Up to 10" (25.4 cm)	Single: left-hand glove	48.99	<b>GB-754-G</b>
	Single: right-hand glove	48.99	<b>GB-755-G</b>
	Pair: one right-hand & one left-hand	79.99	<b>GB-770-G</b>
8" and 10"	Replacement Clamp: fits both port sizes	7.89	<b>GB-CLAMP</b>
<b>SAFETY TIP: NEVER point the Glass Bead Gun at the cabinet window</b>			

## Cleaning Media

### For Part Tumblers

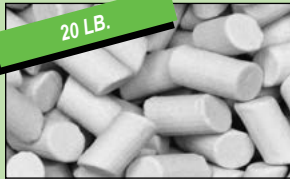

**Ceramic Diagonals (20 lb.)**  
For soft materials such as brass and aluminum. 5/16" dia., 5/8" long  
Order No. **PTM-20CR** Jobber \$72.99



**Steel Ballcones (20 lb.)**  
Ideal for Springs.  
.385" ball in .475" cone  
Order No. **PTM-20BC** Jobber \$154.99



**Steel Diagonals (20 lb.)**  
Ideal for valves.  
5/16" dia., 5/8" long  
Order No. **PTM-20D** Jobber \$149.99

### For Airless Blasters

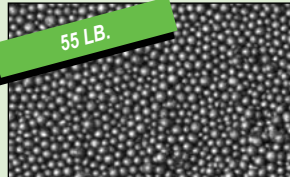

**Steel Shot, 170 grade (55 lb.)**  
Ideal for cleaning cast iron heads.  
Diameter varies from .017" to .024".  
Order No. **SS-CM** Jobber \$49.99

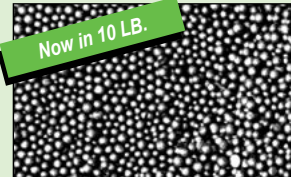

**Stainless Steel Shot, Conditioned.**  
Clean aluminum heads to look like new.  
Restores bright aluminum finish. Lasts longer than plain carbon steel shot.  
Diameter varies from .006" to .016".  
10 lb.  
Order No. **SS-CS10** Jobber \$69.99

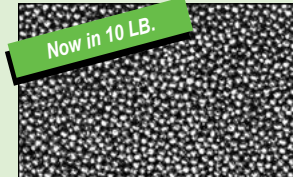

**Stainless Steel Cut Wire Shot**  
Unconditioned. Clean cast iron or aluminum heads before and normalize after welding. Helps prevent surface corrosion after blasting.  
.020" Diameter. 10 lb.  
Order No. **SS-CW10** Jobber \$109.99



### Parts Tumbler Solution

- Dilute 30:1 with water
- For best results, dry parts with compressed air • 1 gallon / 3.78L
- Order No. **PT-SOL** Jobber \$13.99

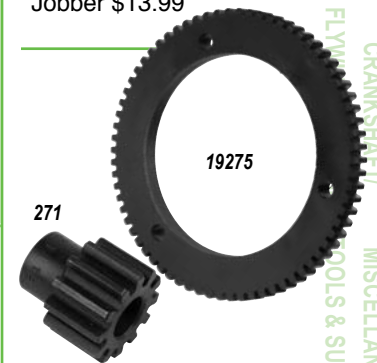

### Replacement Gears For Sioux™ 710 Parts Tumbler

- Replaces discontinued Sioux™ parts

Description	Jobber	Order No.
Steel Gear	\$59.79	<b>271</b>
Fiber Gear	57.79	<b>19275</b>



### Parts Tumbler Basket

- Fits Goodson, K.I., Axe, RMC, and Peterson
- 8" x 12" x 12"
- Order No. **PT-BASKET** Jobber \$274.99

CYLINDER HEAD REBUILDING  
CLEANING, ASSEMBLY & SAFETY  
SHORT BLOCK REBUILDING  
FLYWHEELS  
CRANKSHAFTS  
MISCELLANEOUS TOOLS & SUPPLIES  
BRAKE & TIRE CHANGING TOOLS  
MEASURING TOOLS  
V-TWIN & METRIC HARD PARTS



**The more you buy, the more you save!**  
Order 6 or more pairs of HTG gloves (any combination) & SAVE 10% off jobber!

### Hot Tank Gloves

- Not for solvent use
- Sold in pairs
- Shoulder length features eyelets & strings at tops to prevent slipping

Description	Jobber	Order No.
Gauntlet Length (14" long)	\$23.99	<b>HTG-200</b>
Elbow Length (18 1/2" long)	33.99	<b>HTG-200E</b>
Shoulder Length (34 1/2" long)	47.99	<b>HTG-200L</b>



### Full Length Neoprene Shop Apron

- Protects from caustics, steam, grease and oil
- Bib-style • 35" x 45"
- Order No. **HTA-300** Jobber \$29.99

Shown with Shoulder Length Hot Tank Gloves (above)



### Keeper-Keeper

- Screws closed tightly
- 1/4" holes
- Ideal for tumbling keepers
- Solvent resistant PVC
- Order No. **VK-15** Jobber \$15.99

See Pages 126-127 for Keepers

### Valve Stem Protectors

- Protects against parts tumbler damage
- Slips on and off easily
- 16 per package
- Order No. **VSP-16** Jobber \$12.99

See Page 125 for Valve Stems



### Cloth Shop Apron

- Bib-style apron
- Heavy duty black fabric
- Several handy pockets
- Embroidered Goodson Racing logo
- Machine Washable
- Order No. **CA-100** Jobber \$26.99



CYLINDER HEAD REBUILDING  
CLEANING, ASSEMBLY & SAFETY  
SHORT BLOCK REBUILDING  
CRANKSHAFT/ FLYWHEEL GRINDING  
MISCELLANEOUS TOOLS & SUPPLIES  
BRAKE & TIRE CHANGING TOOLS  
MEASURING TOOLS  
HARD PARTS



### Cosmoline®

- Brush directly from can onto freshly-machined engine components
- Protects iron, steel and aluminum
- Soften with mineral oil to dip small parts

Quantity	Jobber	Order No.
2 lbs.	\$ 31.99	RPC-2A
35 lbs.	379.99	RPC-35A



### Rust Proofing Oil

- Apply full strength
- Creates a protective film
- Washes off with standard solvents
- Brush or spray on using the Sure Shot Sprayer (below)
- 1 Gallon / 3.78 L
- Order No. **RPO-10** Jobber \$89.99



### Silver Anodized Aluminum 24 oz. Sure Shot® Sprayer

- Pressurize it with shop air – 80-150 psi
- No hoses or cords to limit movement
- Spray nozzle adjusts from stream to spray
- Can be used with most oil, solvent and water based materials
- **Not for paint or caustics**

Description	Jobber	Order No.
Sure Shot Sprayer	\$119.99	PS-2014
Replacement Tank-Body O-Ring	10.79	PS-2014OR
Replacement Nozzle Washer	1.49	PS-2014NW



### Sludge Filter Bag

- Fits any machine with a coolant sump
- Replace costly OE filters with this economical, universal sock
- Adds filtration to machines that don't have enough • 8" x 24" polyester knit sock
- Order No. **SB-1** Jobber \$8.99

## Coolant Pumps

### 170 Gal. Per Hour Pump



- HP: 1/125
- Capacity: 170 gal/hr. at 1" depth • Hi-temp Seals
- Voltage: 115
- Size: 4" x 3 3/4" x 2 3/4"
- Order No. **COP-166** Jobber \$119.99

### 1200 Gal. Per Hour Pump



- HP: 1/6
- Capacity: 1200 gal/hr. at 1" depth
- Voltage: 115
- Size: 7 3/4" x 6 1/8" x 4 5/16"
- Order No. **COP-1833** Jobber \$159.99

Order 6 or more cans (any combo), save 10% off jobber



### Rust Shield

- Short-term**
- Non-sticky
  - Lasts several weeks
  - Wipes off with just a towel
- Long-term**
- Formula is thicker and protects much longer but requires a solvent to remove

Formula	Jobber	Order No.
Short Term	\$12.99	RS-16*
Long Term	16.79	RS-16-OD*

\*Hazardous Fees Apply If Shipped Air

### Rust Shield for Shop Equipment

- Stops rust without causing rancidity
- Apply to machine parts such as ways
- Mixes with coolant – no need to remove before machining
- 1 Gallon / 3.78 L
- Order No. **RS-128** Jobber \$27.99



### Adjustable Coolant Hoses

- Universal hoses hold any shape
- Ideal for all crankgrinders, honing machines, flywheel grinders and surface grinding machines
- Snap together hose lets you make any length
- Chemical resistant



Description	Jobber	Order No.
3/4" Hose Kit	\$16.99	ACH-400

Includes 18" long hose, 1/4" & 3/8" NPT fittings, 1/8", 3/8" & 1/2" round nozzles Fits most parts washers, wet-type seat grinders, and valve refacers

Description	Jobber	Order No.
1/2" Hose Kit	17.99	ACH-600

Includes 16 1/2" long hose, 3/8" & 1/2" NPT fittings, 1/4", 3/8" & 1/2" round nozzles  
Fits most cylinder hones and flywheel grinders

1" flare nozzle for 3/4" hoses	\$ 7.99	ACH-407
1 1/4" flare nozzle for 1" hoses	8.99	ACH-807
2 1/2" flare nozzle for 1 1/2" hoses	9.99	ACH-809
3/4" ID hose, 11" long	11.99	ACH-401
1/2" ID hose, 11" long	11.99	ACH-801
1/4" NPT connector for 3/4" ID	6.99	ACH-406
3/8" NPT connector for 1/2" ID	6.99	ACH-804
1/2" NPT connector for 1/2" ID	6.99	ACH-805

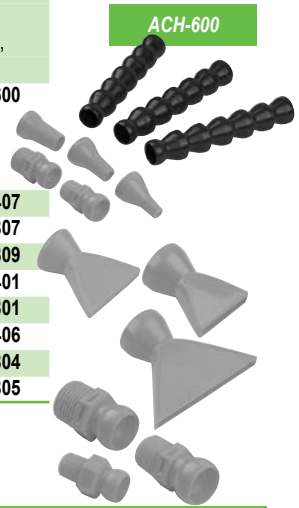

### Universal Coolant Magnet

- Ideal for Honing Tanks, Flywheel Grinders, Crankshaft Grinders, Head Surfacers and more
- Prevents metal swarf from passing into the coolant tank
- Cut or shape to fit machine bases and return ways
- Measures 3"x48"
- Order No. **UCM-348** Jobber \$23.29

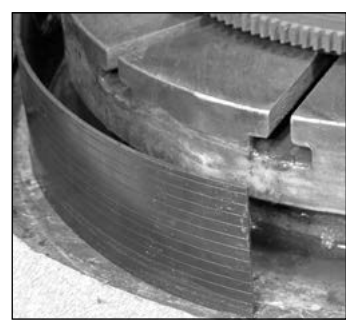



## Defoaming Agent Stops Foaming In Solvents And Coolants

- For jet washers, air-agitated hot tanks and coolant sumps
- Highly concentrated – start with 1 ounce in 50 gallons

Size	Jobber	Order No.
8 oz. / 236.6mL	\$11.79	<b>D-FOAM-10</b>
1 gallon / 3.78L	34.79	<b>D-FOAM-128</b>

## Pro Jet Spray Cleaning Powder

- Heavy-duty • Non-caustic
- Penetrates to emulsify encrusted dirt, grease and oil on cast iron & aluminum
- Won't foam excessively
- Additives prevent scale build-up in jet spray components
- Use to maximum 165° F / 73.9° C
- Mix ratio: 4 oz. per gallon of water
- 50 lb. / 22.68 kg pail
- Order No. **PJS-50** Jobber \$109.99



## Concentrated Hot Tank Detergent Powders For Ferrous Parts

- Strong alkaline • Removes dirt, heavy oil & grease, carbon, light rust & paint
- 25 lbs. • Mix 1/2 lb. to 1 gal.
- Order No. **D-CI25** Jobber \$104.99



## For Non-Ferrous Parts

- Safe on aluminum & sensitive metals, rubber & plastic parts • Removes heavy grease & oil • 50 lb. pail • Mix ratio: 1/4 lb. to 1 gal. • Order No. **D-AL50** Jobber \$137.79



## pH Test Strips

- Easy to use • 100 tests per package
- Use the handy guide on the box to determine pH between 0 and 14
- Order No. **HT-PH** Jobber \$39.99

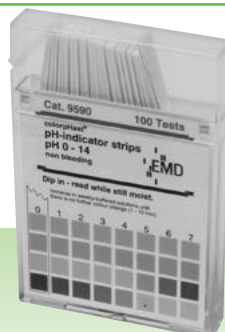

**tech tips**  
from the techxperts™

### Pay attention to the mix ratio on cleaning products!

It's important that you start mixing on the weak side and work your way up. An overly strong concentration is just as ineffective as an overly weak mixture. Use pH Test Strips to check the concentration.

## Multi-Purpose Parts Degreasing Detergent

- Highly versatile detergent cleans a variety of things in and around your shop - floors, machines, parts, countertops, benchtops and more
- **Not for use in Jet Wash**



Size	Jobber	Order No.
1 Gallon / 3.78L	\$24.99	<b>PD-10</b>
5 Gallons / 18.39L	99.99	<b>PD-50</b>

## Micro Biostat

- Controls bacteria and fungus in coolant reservoirs
- Treat at 1 oz. per 5 gallons of capacity
- Operate machine for 30 minutes then empty the reservoir
- Refill with coolant and treat 1 oz. per 10 gallons
- Re-treat every 10 days to 2 weeks as needed so it can't happen again
- 20 oz. / 591.5mL bottle
- Order No. **GBP-20** Jobber \$32.99



## Ultrasonic Detergents

- Safe for ferrous metals & aluminum
- Medium Duty can also be used on plastic
- For ultrasonic immersion tanks
- Medium Duty includes rust preventive
- Exceptional ultrasonic cleaning
- 5 gallons / 18.39L containers

Description	Mix Ratio	Jobber	Order No.
Medium Duty	1:20	\$127.99	<b>USD-MD50</b>
Heavy Duty	1:10	109.99	<b>USD-HD50</b>

### Replacement Cartridge Filters for Ultrasonic Cleaners (2" x 9"L)

Filtration	Jobber	Order No.
30 microns	\$13.99	<b>USF-30</b>
50 microns	13.99	<b>USF-50</b>



## ARMEX®

### Maintenance XL Formula Soda Blast Cleaning Media

- 270 micron / 70 Grit Formula
- Use to strip clean almost any car surface including, steel, aluminum, Fiberglas® and plastics
- Ideal for blocks, heads and intake manifolds
- Dissolves in warm water, minimizing particle ingestion that can block fuel lines and passageways
- Won't damage the surface you're cleaning
- Non-toxic and non-hazardous with a pH of 8.2
- 50 lb. / 22.7 kg bags
- Order No. **SMB-170** Jobber \$34.99



CYLINDER HEAD  
REBUILDING  
CLEANING, ASSEMBLY & SAFETY  
SHORT BLOCK  
REBUILDING  
CRANKSHAFT/  
FLYWHEEL GRINDING  
TOOLS & ACCESSORIES  
MISCELLANEOUS  
BRAKE & TIRE  
CHANGING TOOLS  
MEASURING  
TOOLS  
V-TWIN & METRIC  
HARD PARTS



"I make sure that all Goodson products are packaged properly and include instructions or important information that is useful to our customers."

- Jill, Goodson Receiving Department - 13 years of service

CYLINDER HEAD REBUILDING  
CLEANING, ASSEMBLY & SAFETY  
SHORT BLOCK REBUILDING  
CRANKSHAFT/ FLYWHEEL GRINDING  
MISCELLANEOUS TOOLS & SUPPLIES  
BRAKE & TIRE CHANGING TOOLS  
MEASURING TOOLS  
V-TWIN & METRIC HARD PARTS

## Organize, Clean And Store Small Parts With GOODSON

### Small Parts Baskets

- Galvanized, welded 1/4" mesh
- Withstands most solvents
- Not for use in caustics



### Small Basket with Lid

- 2 1/4" dia. x 7" L
- Order No. **PWB-2** Jobber \$10.99



### Medium Basket with Lid

- 4 1/2" dia. x 7" L
- Order No. **PWB-4** Jobber \$12.99



### Single Basket with Handle

- 8" dia. x 9" L
- Lid & clip sold separately
- Order No. **PWB-10** Jobber \$14.49



### Single Basket with Lid, Clip & Handle

- 8" dia. x 9" L
- Order No. **PWB-15** Jobber \$22.99



### Double Basket with Clip

- 9" dia. • 16" L
- Hinged on one side
- Order No. **PWB-25** Jobber \$23.99



### Lid & Clip

- For PWB-10
- Order No. **PWB-10L** Jobber \$8.99

### Clip Only

- Order No. **PWB-15C** Jobber \$2.99

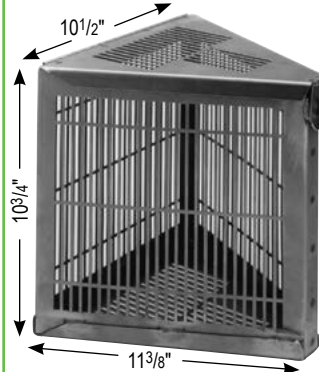

## Jet Wash Parts Basket Makes a 24" Circle

- Triangle-shaped • Sit side by side on Jet Wash table
- Fit more baskets in the machine to clean faster
- Order No. **JWB-6** Jobber \$104.99



Buy a set of six and save 10% off jobber



## Gauntlet Style Heat & Flame Resistant Gloves

- Heavy, lined red terrycloth
- 13 1/2" Long
- Safe to 450°F / 232.2°C
- Order No. **HR-300** Jobber \$29.99



## Mirrored Safety Glasses

- Tinted lenses provide sun glare protection
- Universal bridge
- Polycarbonate lenses
- Do not use as welders helpers
- Order No. **PGL-21** Jobber \$4.99

## Nitrile Parts Washing Gloves



### Lined

- Nitrile exterior • Flock lined
- Won't swell • 13" long
- Safe for solvents

Size	Jobber	Order No.
Large	\$7.99	<b>PWG-SOL-L</b>
X-Large	9.99	<b>PWG-SOL-XL</b>



### Unlined Gloves

- Industrial quality textured Nitrile • 12" Long
- Fit either hand

Size	Qty.	Jobber	Order No.
Large	50	\$15.99	<b>PNGL-L</b>
X-Large	50	15.99	<b>PNGL-XL</b>

Buy 2 or more boxes of gloves and save 10% off jobber

## Machine Washable Cotton Shop Towels

- 15"/381mm square
- Highly absorbent
- Hundreds of uses
- Color may vary



Quantity	Jobber	Order No.
5 Pack	\$ 3.99	<b>WST-5</b>
50 Pack	16.99	<b>WST-50</b>

## Disposable Assembly Wipes

- Snow-white
- Shows dirt easily
- Pop-up box • 9" x 17"
- Ideal for a multitude of uses at the shop, at the track, even at home!



Quantity	Jobber	Order No.
100	\$19.99	<b>AW-100</b>
220	24.29	<b>AW-250</b>

**YOUR BEST VALUE!**

# Parts Organization & Storage

## Parts Tags & Marker

- Won't tear or wash off
- Tough enough to go through a jet wash or hot tank
- Heavy wire ties
- Includes 2 permanent markers
- Tag dimensions: 3½"L x 5/8"W with 5/32" hole for wire tie



Description	Jobber	Order No.
1000 Parts tags, with 2 markers	\$53.99	IDT-1000
Permanent Marker only	1.99	IDT-MARKER

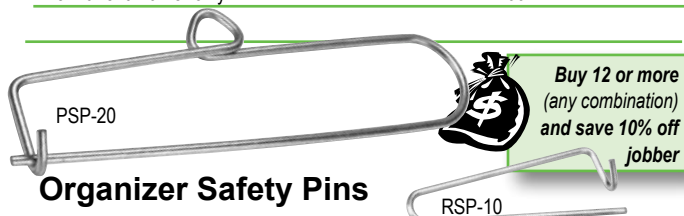

## Organizer Safety Pins

### Keep Part Sets Together

- Parts Safety Pin** • Organize valve springs, rods, etc., from disassembly to cleaning to reassembly
- Rod & Cap Mini Pin** • Keep connecting rods & rod caps together to prevent mix-ups

Description	Jobber	Order No.
Parts Safety Pin (3¾" x 12")	\$7.99	PSP-20
Rod & Cap Mini Pin (¾" x 4")	4.99	RSP-10

## Shrink Wrap

- Easy-to-use
- High-clarity film
- Keep machined surfaces clean
- Protects from dirt, dust and moisture
- No need to stock several bag sizes

Size	Jobber	Order No.
5" x 1000' w/ Extended Core	\$13.99	SW-5
18" x 1500' with 3" core	34.99	SW-18



## Heavy Duty Steel Stamps

- For hard materials
- Order in sets or individually
- For a single stamp, state character desired after Order No. Example: **SCH-1/4(A)**  
Single Character stamp, ¼" size, Letter "A"



Number Sets		Jobber	Order No.
Char. Size	Shank Size		
½"	5/16"	\$44.99	SFH-1/8
3/16"	3/8"	49.99	SFH-3/16
Single Characters			
3/16"	3/8"	\$8.99	SCH-3/16
¼"	7/16"	8.99	SCH-1/4

Special and custom orders are available, call 1-800-533-8010

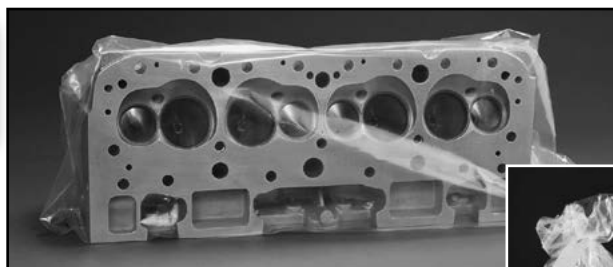

## Engine & Parts Storage Bags

- Rugged, 3-mil thickness resists tearing
- Engine bags feature 4-mil thickness for extra strength
- Protects your professional work

- Waterproof • Protect finished work from damage • 4 sizes fit most common rebuilt assemblies • Jumbo engine bags are extra-strong and big enough to accommodate complete engines • Jumbo head bags fit the largest cylinder heads
- Ideal for storing heads, cranks, blocks, etc.

Size	Description	Quantity	Jobber	Order No.
16" x 37"	Heads, cranks, misc.	box of 100	\$ 62.99	BC-15
17" x 44"	Jumbo head bag	roll of 100	69.99	BC-17
27" x 18" x 36"	Box-style for blocks	box of 50	69.99	BE-20
44" x 52"	Jumbo engine bag	roll of 50	129.99	BE-44

Order 6 or more cans (any combination), save 10% off jobber

## Short Term Rust Shield Aerosol

- Non-sticky
- Lasts several weeks
- Wipes off with just a towel
- Order No. **RS-16\***  
Jobber \$12.99



## Long Term Rust Shield Aerosol

- Formula is thicker and protects much longer but requires a solvent to remove
- Order No. **RS-16-OD\***  
Jobber \$16.79

\*Hazardous Goods Fees Apply to Aerosols When Shipped By Air

CYLINDER HEAD REBUILDING  
CLEANING, ASSEMBLY & SAFETY  
SHORT BLOCK REBUILDING  
CRANKSHAFT/ FLYWHEEL GRINDING TOOLS & SUPPLIES  
MISCELLANEOUS  
BRAKE & TIRE CHANGING TOOLS  
MEASURING TOOLS  
V-TWIN & METRIC HARD PARTS

## Last Blast & Hi-Temp Last Blast



**The more you buy, the more you save**

Order a case of 12 and save 15% off jobber  
 Mix and match colors to make a case.



## Last Blast Spray Paint

- Quick-dry formula lets you handle parts in minutes
- Pigment won't smudge
- Resists abrasion, corrosion and most solvents
- Paint heads, blocks and parts just like OE
- Withstands heat up to 250°F/121.1°C
- **Last Blast** restores a "fresh from the bead-blast" look to all types of cast iron
- **Aluminum Last Blast** makes aluminum heads and parts look new
- **Color Last Blast** in popular, factory colors

Color	Jobber	Order No.
Cast Iron Gray	\$6.49	LB-1*
Aluminum Gray	6.49	ALB-1*
GM Black (Gloss)	6.99	CLB-58*
Ford/Chrys. Red	6.99	CLB-59*
Ford Blue	6.99	CLB-60*
Chevy Orange	6.99	CLB-61*

\*Hazardous Goods Fees Apply When Shipped Air



## Hi-Temp Last Blast



- Hard, chemical-resistant finish
- Withstands continuous heat up to 1200°F/648.9°C
- Won't deteriorate like ordinary paints
- For blocks, manifolds, or any external parts subjected to high heat
- Dries tack-free in 10 min., then heat at 450°F/232.2°C for 1 hour to create a professional, durable finish

Color	Jobber	Order No.
Cast Iron Gray	\$7.79	LB-1-HT*
Aluminum Gray	6.99	ALB-1-HT*
Black (Matte)	6.99	CLB-58-HT*

\*Hazardous Goods Fees Apply When Shipped Air



## Metal Markers

- No shaking needed
- Quick drying
- Withstands oil, grease and surface contact
- Won't lose its brilliance or legibility



Color	Order No.
Orange	MM-STD
Black	MM-010
Yellow	MM-030
White	MM-050
Green	MM-060
Red	MM-070
Blue	MM-080

Jobber \$6.49

Buy 5,



(any combination)  
 save 10% off jobber

## High-Performance Hylomar® Gasket Maker & Thread Sealer

- Maintains seal integrity up to 600°F / 315.5°C
- Polyol-based compound turns from a gel into flexible putty within minutes of application
- Non-hardening formula is impervious to oil, gasoline, glycol and other engine fluids
- Oxygen-sensor safe
- Seals gaps .01" or less
- 100 gram tube
- Order No. **HBS-1**  
 Jobber \$21.99



## 2" Dispensing Pliers for Flexible Tubes

- Maximizes the use of all the material in the tube due to its effective means of application
- Dispenses even the thickest sealant through a very small opening, permitting better application control
- Reduces both cleanup time and the possibility of skin contact or other problems caused by excess material squeeze-out
- Order No. **EB-416** Jobber \$19.29



## Protect Your Assembled Heads and Block with Jumbo Engine Bags

- 4 mil thickness
- 44" x 52"
- 50 per roll
- Order No. **BE-44**  
 Jobber \$129.99



# Assembly & Break-In

Buy 12 or more and SAVE 10% off jobber!



## Press Fit Lube

- A light coat eases press fit
- Ideal for valve guides, piston pins, cylinder sleeves, etc.
- Eliminates the scoring, gouging and galling of parts during press fitting
- 6 oz. / 177.4mL • Aerosol\*
- Order No. **PFL-200** Jobber \$11.99

\*Hazardous Goods Fees Apply When Shipped Air



## Press Fit Lubricant

- A light coat eases assembly
- Multiple applications
- Eliminates scoring gouging and galling of parts during press fitting

Description	Jobber	Order No.
Aerosol 7 oz. / 207 mL	\$ 17.99	<b>B-200*</b>
Brush Applicator 200 mL	25.99	<b>B-200L</b>

\*Hazardous Goods Fees Apply When Shipped Air



## Extreme Pressure Lube

- Withstands pressures up to 50,000 PSI
- Highly refined petroleum product
- Contains no lead, graphite or minerals
- Won't corrode fine surfaces or emulsify with cooling liquids
- Surfaces stay lubed and protected
- In a grease form • 4 fl. oz. / 118.29mL
- Order No. **EPL-4** Jobber \$7.99

## Disposable Assembly Wipes

- Snow-white
- Shows dirt easily
- Pop-up box
- 9" x 17"
- Ideal for a multitude of uses at the shop, at the track, even at home!



Quantity	Jobber	Order No.
100	\$19.99	<b>AW-100</b>
220	<b>YOUR BEST VALUE!</b>	24.29 <b>AW-250</b>

iron-clad guarantee

## First Lube Engine Assembly Lube

- Prevent dry engine start-ups after long-term storage
- Clings and forms a slick wall between moving parts
- Withstands start-up pressure
- Compatible with all motor oils



Size	Jobber	Order No.
8 oz. / 236.6mL	\$ 6.99	<b>FL-10</b>
1 gallon / 3.78L	37.99	<b>FL-128</b>

## Cam-Shield® Camshaft Assembly Paste

- Provides anti-wear protection for camshafts during break-in
- 2500 parts per million of Zinc
- Use with mechanical and hydraulic camshafts & lifters
- For racing, street, classic, agricultural, diesel and marine camshafts



Size	Jobber	Order No.
5/8 oz. / 22.18mL Packet	\$ 4.79	<b>CSAP-625</b>
4 oz. / 118.29mL Brush Top Jar	17.99	<b>CSAP-4</b>

## Blood Friction Master® Engine Assembly Lube

- Contains a low friction additive for dry start-ups
- Forms a slick wall between moving parts
- Clings until dissolved by oil
- Withstands start-up pressure
- Compatible with all motor oils
- Ideal for high performance



Size	Jobber	Order No.
8 oz./236.6 mL w/brush	\$ 13.99	<b>AL-22-8</b>
1 gal./3.78 L w/pump	133.99	<b>AL-22-10</b>

## Spray Assembly Lube

- Ideal for prelubricating parts to ease assembly
- Eliminates critical initial run-in of new and rebuilt high-performance engine components
- Spray on bearings, crankshafts, pistons, rings, etc.
- Aerosol\* • Order No. **SAL-11** Jobber \$13.79

\*Hazardous Goods Fees Apply If Shipped Air



Buy 6 cans or more and SAVE 10% off jobber!



CYLINDER HEAD  
REBUILDING  
CLEANING,  
ASSEMBLY & SAFETY  
SHORT BLOCK  
REBUILDING  
CRANKSHAFT/  
FLYWHEEL GRINDING  
MISCELLANEOUS  
TOOLS & SUPPLIES  
BRAKE & TIRE  
CHANGING TOOLS  
MEASURING  
TOOLS  
V-TWIN & METRIC  
HARD PARTS



"We offer every customer the opportunity to open a Goodson account for faster, easier ordering and to save you money on C.O.D. shipments. Call today for details!"

- Diane, Goodson Customer File Maintenance - 15 years of service

Order 3 or more Flex-Hones® (mix & match) and save 10% off jobber



## Valve Guide Flex-Hones®

• Kit includes the most popular sizes for valve guide work

	400 Grit Diamond		320 Grit Silicon-Carbide		240 Grit Silicon-Carbide	
Size mm	OAL	Order No.	Jobber	Order No.	Incl.	
<b>6 Pc. Valve Guide Kit</b>						
				\$84.99	<b>VGFD-KIT</b>	▼
5/32"	4.0	6"	<b>VGFD-4MM</b>		<b>VGFD-4MM</b>	
11/64"	4.5	6"	<b>VGFD-4.5MM</b>		<b>VGFD-4.5MM</b>	
13/64"	5.0	8"	<b>VGFD-5MM</b>	<b>VGFD-5MM-320</b>	<b>VGFD-5MM</b>	
7/32"	5.5	8"	<b>VGFD-5.5MM</b>	<b>VGFD-5.5MM-320</b>	<b>VGFD-5.5MM</b>	
1/4"	6.4	8"	<b>VGFD-6.4MM</b>	<b>VGFD-6.4MM-320</b>	<b>VGFD-6.4MM</b>	x
9/32"	7.0	8"	<b>VGFD-7MM</b>		<b>VGFD-7MM</b>	x
5/16"	8.0	8"	<b>VGFD-8MM</b>		<b>VGFD-8MM</b>	x
11/32"	9.0	8"	<b>VGFD-9MM</b>		<b>VGFD-9MM</b>	x
3/8"	10.0	8"	<b>VGFD-10MM</b>		<b>VGFD-10MM</b>	x
7/16"	11.0	8"	<b>VGFD-11MM</b>	<b>VGFD-11MM-320</b>	<b>VGFD-11MM</b>	x
15/32"	12.0	8"	<b>VGFD-12MM</b>		<b>VGFD-12MM</b>	
1/2"	12.7	8"		<b>VGFD-12.7MM</b>		
33/64"	13.0	8"	<b>VGFD-13MM</b>		<b>VGFD-13MM</b>	
9/16"	14.0	8"	<b>VGFD-14MM</b>		<b>VGFD-14MM</b>	
19/32"	15.0	8"	<b>VGFD-15MM</b>		<b>VGFD-15MM</b>	
			Jobber \$39.79	Jobber \$25.29	Jobber \$20.99	

## Flex-Hones® For any type and size of cylinder

- Abrasive globules each have independent suspension
- Self-centering • Self-aligning • Self-compensating for wear
- Applications are interchangeable, select bore size
- Right Hand rotation only
- **Brake Rotor Flex-Hones®**, pg. 114 • **Plateau Soft Hones**, pg. 81
- **Honing Oil**, pg. 73

**Silicon-Carbide**  
Ideal for all materials including cast iron, bronze, phosphor bronze and aluminum.

**Aluminum-Oxide**  
Ideal for hard surfaces such as Nicasil and hardened steel

**Diamond**  
Ideal for heat treated steel, high nickel stainless steel, chromes or plated bores, MMX aluminum alloys, ceramics and carbide

**Right Hand Rotation Only!**   
For best results, always use with an ample flow of honing oil.

## Ordering the right size Flex-Hone®

Order by actual cylinder ID. All Flex-Hones® are produced oversize. If your cylinder ID is non-standard, order the next larger size. For example, for a cylinder that has been machined to 3 3/8" diameter, order a 3 1/2" cylinder hone. The "flex" that's built into the Flex-Hone® will adjust to the size difference. **NOTE:** If purchasing the 120 Grit Heavy Duty Flex-Hones®, order on cylinder size.

Size	Silicon-Carbide						Aluminum Oxide			
	120 Grit Standard		120 Grit Heavy-Duty		180 Grit Standard		240 Grit Standard			
mm	OAL	Jobber	Order No.	OAL	Jobber	Order No.	OAL	Jobber	Order No.	
5/8"	15.9				8"	\$17.29	<b>BH-625</b>			
3/4"	19.1				8"	17.99	<b>BH-750</b>			
13/16"	20.6				8"	21.79	<b>BH-820</b>			
7/8"	22.2				8"	18.29	<b>BH-875</b>			
1"	25.4				8"	19.29	<b>BH-1000</b>			
1 1/8"	28.6				8"	20.29	<b>BH-1125</b>			
1 1/4"	31.8				8"	21.79	<b>BH-1250</b>			
1 3/8"	34.9				8"	22.49	<b>BH-1375</b>			
1 1/2"	38.1				8"	23.99	<b>BH-1500</b>			
1 5/8"	41.3				8"	23.99	<b>BH-1625</b>			
1 3/4"	44.5				8"	24.99	<b>BH-1750</b>	17 1/2"	\$44.29	<b>CBF-175</b>
2"	50.8	8"	\$25.99	<b>BG-210</b>	8"	25.99	<b>BH-2000</b>	17 1/2"	44.79	<b>CBF-200</b>
2 1/4"	57.2	8"	27.79	<b>BG-225</b>	8"	28.29	<b>BH-2250</b>	17 1/2"	46.79	<b>CBF-225</b>
2 3/8"	60.2							8"	\$32.79	<b>BG-125320</b>
2 1/2"	63.5	8"	30.29	<b>BG-250</b>	8"	30.29	<b>BH-2500</b>	17 1/2"	48.79	<b>CBF-250</b>
2 5/8"	66.5							8"	36.29	<b>BG-150320</b>
2 3/4"	69.8	8"	33.49	<b>BG-275</b>				8"	36.79	<b>BG-162320</b>
3"	76.2	8"	38.79	<b>BG-300</b>	8"	33.49	<b>BH-2750</b>	17 1/2"	60.99	<b>CBF-275</b>
3 1/4"	82.6	13 1/2"	\$63.49	<b>BGD-300</b>	8"	58.29	<b>BG-300320</b>	8"	49.49	<b>BA-300240</b>
3 1/2"	88.9	13 1/2"	43.79	<b>BG-325</b>	13 1/2"	65.49	<b>BGD-325</b>	13 1/2"	65.79	<b>BG-325320</b>
3 3/4"	95.3	13 1/2"	47.29	<b>BG-350</b>	13 1/2"	67.79	<b>BGD-350</b>	13 1/2"	69.89	<b>BG-350320</b>
4"	101.6	13 1/2"	50.29	<b>BG-375</b>	13 1/2"	72.29	<b>BGD-375</b>	13 1/2"	75.29	<b>BG-375320</b>
4 1/8"	104.8	13 1/2"	53.49	<b>BG-418</b>	13 1/2"	76.99	<b>BGD-400</b>	13 1/2"	80.29	<b>BG-418320</b>
4 1/4"	107.9				13 1/2"	82.49	<b>BGD-425</b>	13 1/2"	67.99	<b>BA-418240</b>
4 3/8"	114.3	13 1/2"	67.79	<b>BG-438</b>				13 1/2"	99.99	<b>BG-438320</b>
4 1/2"	114.3	13 1/2"	67.79	<b>BG-462</b>	13 1/2"	87.79	<b>BGD-450</b>	13 1/2"	104.99	<b>BG-462320</b>
4 5/8"	117.5	13 1/2"	67.79	<b>BG-462</b>	13 1/2"	99.79	<b>BGD-500</b>	13 1/2"	75.79	<b>BA-462240</b>
5"	127.0				17 1/2"	115.49	<b>BGD-550</b>			
5 1/2"	139.7				17 1/2"	118.49	<b>BGD-600</b>			
6"	152.4				17 1/2"	127.79	<b>BGD-650</b>			
6 1/2"	165.1				17 1/2"	139.29	<b>BGD-700</b>			
7"	177.8				17 1/2"	152.99	<b>BGD-750</b>			
7 1/2"	190.5				17 1/2"	162.79	<b>BGD-800</b>			
8"	203.2									

### Heavy Duty 320 Grit Flex-Hones®

• Silicon-Carbide • Order on size

Size	OAL	Jobber	Order No.
4"	13 1/2"	\$118.79	<b>BGD-400320</b>
4 1/4"	13 1/2"	131.29	<b>BGD-425320</b>
4 1/2"	13 1/2"	132.49	<b>BGD-450320</b>

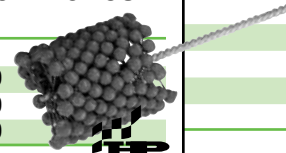



## Coolants and Lubricants

We don't stock one type of coolant and claim that it suits all types of grinding, nor do we carry one type of oil and try to sell it for every application. Each of our many types of coolants, lubricants and oils is formulated to deliver better results and longevity in its specific use. All of our coolants prolong the life of grinding wheels, retard corrosion and rancidity. Colors may vary.

### All-Purpose Grinding Coolant

A synthetic water soluble coolant that "Licks Rust". Dilute 30:1

Size	Yield	Jobber	Order No.
1 gal./3.78L	30 gallons	\$ 29.99	<b>CGC-1288</b>
5 gal./18.9L	150 gallons	139.99	<b>CGC-5288</b>

### Crank & Cam Grinding Coolant

Synthetic, non-nitrate, high lubricity coolant. Dilute 20:1

Size	Yield	Jobber	Order No.
1 gal./3.78L	20 gallons	\$ 33.99	<b>CGC-10</b>
5 gal./18.9L	100 gallons	149.99	<b>CGC-50</b>

### Multi-Duty Grinding Coolant

Medium-duty, low foaming, synthetic coolant with rust inhibitors. Safe for ferrous and non-ferrous metals alike. No nitrates, phenols, chlorine or sulfur.

Dilute 30:1

Size	Yield	Jobber	Order No.
1 gal./3.78L	30 gallons	\$ 37.99	<b>GPC-10</b>
5 gal./18.9L	150 gallons	179.99	<b>GPC-50</b>

### Belt-Resurfacing Coolant

For all belt-type resurfacers with or without down-pressure. Dilute 30:1

Size	Yield	Jobber	Order No.
1 gal./3.78L	30 gallons	\$ 29.99	<b>SGB-10</b>
5 gal./18.9L	150 gallons	144.99	<b>SGB-50</b>

### Resurfacing Coolant

Non-foaming, non-nitrate coolant for single-piece or segmented wheels. Dilute 20:1

Size	Yield	Jobber	Order No.
1 gal./3.78L	20 gallons	\$ 29.99	<b>SGC-10</b>
5 gal./18.9L	100 gallons	134.99	<b>SGC-50</b>

### Flywheel Grinding Coolant

A synthetic rust inhibitor that prevents rancidity. For all flywheel grinders. Dilute 30:1

Size	Yield	Jobber	Order No.
1 gal./3.78L	30 gallons	\$ 41.99	<b>FG-1101-G</b>
5 gal./18.9L	150 gallons	149.99	<b>FG-1102-G</b>

## Cutting Oils

### Knurlube

Lubricate while knurling.

Size	Jobber	Order No.
8 oz./236.6mL	\$10.49	<b>WLB-46-G</b>
32 oz./946.4mL	14.79	<b>WLB-47-G</b>

### Cutting Aids (Aerosol\*)

Helps tools cut through the hardest of metals. Clings to the surface of the tool, keeping it cool while prolonging its life.

Size	Jobber	Order No.
Cutting & Tapping Fluid	\$12.49	<b>CTF-14*</b>
Resurfacing Spray	11.99	<b>HPS-16*</b>

\*Hazardous Goods Fees Apply If Shipped Air

### Valve Seat Cutting Fluid

High-silicone lube cuts drag on cutters for a better finish, longer tool life. Dilute 9:1. Water soluble.

Size	Jobber	Order No.
16 oz./473.2mL	\$13.99	<b>SCF-2</b>
1 gal./3.78L	29.99	<b>SCF-10</b>

### Bronze Reaming Oil

Cuts bronze build-up while reaming. Longer tool life. Better valve guide finish.

Size	Jobber	Order No.
16 oz./473.2mL	\$ 9.99	<b>BW-303-G</b>
32 oz./946.6mL	15.99	<b>BW-303A-G</b>
1 gal./3.78L	35.99	<b>BW-305-G</b>

### Lap Oil

This very fine oil prolongs the life of diamond laps. A light coat cools, lubricates and prevents wear.

Size	Jobber	Order No.
4 oz./118.3mL	\$10.49	<b>LP-LO-4</b>
8 oz./236.6mL	\$17.99	<b>LP-LO-8</b>

### Tap Oil

Makes tapping easier & faster. Breaks down surface tension. Eliminates scuff marks & gouging. Reduces tap breakage & improves thread quality.

Size	Jobber	Order No.
7.5 oz./221.8mL	\$15.79	<b>TAP-O</b>

## Grinding & Honing Oils (Not Water Soluble)

### Cylinder Honing Oil (Clear)

Ideal for portable hones and all makes of automotive honing machines. Mixes readily with other brands (including Sunnen®).

Size	Jobber	Order No.
1 gal./3.78L	\$ 26.99	<b>HO-10</b>
5 gal./18.9L	114.99	<b>HO-50</b>
55 gallons	Call	<b>HO-550</b>

### Rod Honing Oil (Dark Brown)

Keeps stones clean & free-cutting during rod reconditioning, pin fitting and other honing jobs. Will mix with other brands (including Sunnen®).

Size	Jobber	Order No.
1 gal./3.78L	\$ 34.99	<b>RHO-10</b>
5 gal./18.9L	174.99	<b>RHO-50</b>
55 gallons	Call	<b>RHO-550</b>

### Titanium Valve Grinding Aid

Mix ratio of 1:4. Add to valve grinding oil.

Size	Jobber	Order No.
32 oz./946.6mL	\$42.99	<b>VGA-T32</b>

### Diamond Honing Oil (Brown)

Specially formulated to withstand the cutting pressures created when using our Diamond Valve Guide Honing System.

Size	Jobber	Order No.
8 oz./236.6mL	\$ 5.29	<b>DHO-8</b>
1 gal./3.78L	38.99	<b>DHO-10</b>
5 gal./18.9L	174.99	<b>DHO-50</b>

### Valve Grinding Oil (Light Yellow)

Universal valve grinding oil extends wheel life. Mineral based.

Size	Jobber	Order No.
1 gal./3.78L	\$ 29.99	<b>VGO-10</b>
5 gal./18.9L	119.99	<b>VGO-50</b>

### Severe Duty Valve Grinding Oil (Brown)

For grinding titanium, Inconel®, stainless steel and stellite valves.

Size	Jobber	Order No.
1 gal./3.78L	\$ 34.99	<b>VGO-SD10</b>
5 gal./18.9L	174.99	<b>VGO-SD50</b>

## Machine Lubricants

### Flywheel Grinder Table Lubricant

Helps extend flywheel grinder life. This high-pressure oil is designed to lubricate table bearings and ways. For all makes of flywheel grinders.

Size	Jobber	Order No.
1 gal./3.78L	\$39.99	<b>FG-1131-G</b>

### Way Oil

Adhesive oil formulated to provide extended lubrication and rust protection for machine-tool ways.

Size	Jobber	Order No.
1 gal./3.78L	\$29.99	<b>WO-50</b>

### Rust Shield for Shop Equipment

Prevents rust and won't cause rancidity. Protective film mixes with coolant so you don't have to clean it off before using the machine.

Size	Jobber	Order No.
1 gal./3.78L	\$27.99	<b>RS-128</b>

... another satisfied customer



"Thanks to all the folks at Goodson for the great products and service for our machine shop so quickly!"

- Doug Herbert, Doug Herbert Racing via Twitter (@DougHerbert)

CYLINDER HEAD REBUILDING  
CLEANING, ASSEMBLY & SAFETY  
SHORT BLOCK REBUILDING  
CRANKSHAFT/ FLYWHEEL GRINDING  
MISCELLANEOUS TOOLS & SUPPLIES  
BRAKE & TIRE CHANGING TOOLS  
MEASURING TOOLS  
V-TWIN & METRIC HARD PARTS

## WINONA VAN NORMAN, VAN NORMAN, PETERSON, KI (PK447S)

### 1-EDGE CUTTER BIT

Fits Model Numbers	For	Bit Dia.	Jobber	Order No.
777, 900, 905, 944, 965	General	1/4"	\$38.99	VN-1
777S, 777S4, 944S, CB11, BC22XL	General	3/8"	38.99	VGS-1
	Hard Sleeves	3/8"	38.99	VGS-2
	Sleeve Cutter	3/8"	38.99	VGS-3
888, 999	General	7/16"	58.99	VN-360

### Original Van Norman

Fits Model Numbers	For	Bit Dia.	Jobber	Order No.
777S, 944S	Hard Sleeves	3/8"	\$49.99	777-179

### HOLDERS FOR 6-EDGE TIPS - Use RT-6B and RT-6BT

Fits Model Numbers	Length	Height	Jobber	Order No.
777, 900, 905, 944, 965	1 7/8"	3/4"	\$157.99	VN-135
	2 1/2"	3/4"	157.99	VN-136
777S, 777S4, 944S	2"	1 3/16"	159.99	VN-122

Bore Range: 2.65" to 4.50"

Standard Carbide Replacement Cutter Tip	8.99	RT-6B
Titanium Coated Carbide Replacement Tip	9.99	RT-6BT

### Fits Model Numbers - Use FG-3B

CB11, CB22XL	3/8" diameter	\$87.99	VN-129
Standard Carbide Replacement Cutter Tip		9.99	FG-3B

### MISCELLANEOUS PARTS

Fits 6-Edge Holders Above	Description	Jobber	Order No.
	Bit Screw	\$3.29	VN-130

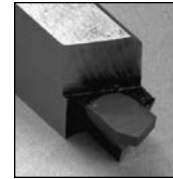
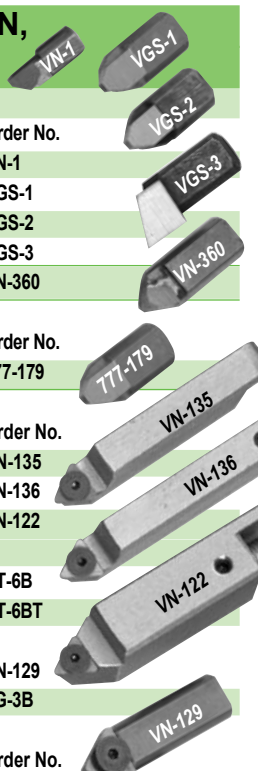

### Single-Piece (Solid) Style

Holder with integral cutting bit. Excellent cutting performance. Resharpenable. When no longer usable, replace entire cutter.



### 1-Edge Replaceable Type

Tool holder with separate bit. Excellent cutting yet economical. Resharpener the cutter bit many times. When no longer usable, replace only the bit.

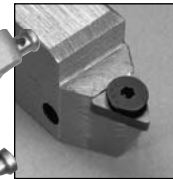

### 6-Edge Replaceable Type

Lowest-cost choice. Holders take 6-edge, replaceable tips. When one edge wears, turn to new surface. Never need to resharpen - just replace the tip.

The more you buy, the more you save!



Order 10 - 29 Tips, save 10% off jobber  
Order 30 or more, save 20% off jobber

## KWIK-WAY

### 1-EDGE CUTTER BIT FOR OE HOLDERS

Fits Model Numbers	Type	Bit Dia.	Jobber	Order No.
F, FT, FL, FN, FR, FS,	Rough	5/16"	\$29.99	KWL-R
FW, FWS, FWSII, FX	Finish	5/16"	29.99	KWL-F
Models After 1770	Sleeve Cutter	5/16"	29.99	KWL-C

### HOLDER FOR 6-EDGE TIPS - Uses RT-6B or RT-6BT Tips

Fits Model Numbers	Length	Height	Jobber	Order No.
FL, FN, FR, FS, FT, FW	2 5/16"	5/8"	\$134.99	KWL-116
Standard Carbide Replacement Cutter Tip			8.99	RT-6B
Titanium Coated Carbide Replacement Cutter Tip			9.99	RT-6BT

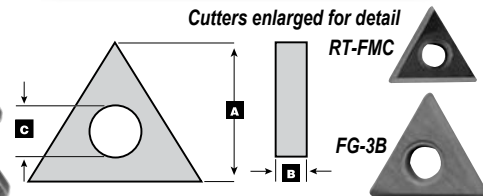
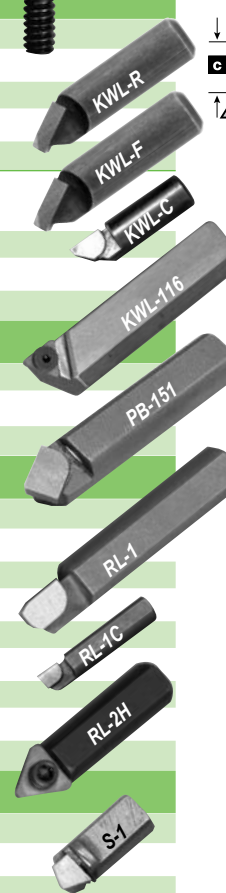

## Replacement Tips & Parts

• Fit most boring bar holders

A	B	C	Edges	Jobber	Order No.
<b>Standard Carbide</b>					
.358"	.097"	.108"	3	\$17.99	SEQ-1
.345"	.094"	.140"	6	8.99	RT-6B
.447"	.124"	.149"	3	3.69	RT-FMC
.360"	.094"	.124"	3	9.99	FG-3B
.327"	.094"	.140"	3	10.99	RL-2T
<b>Titanium Coated</b>					
.345"	.094"	.140"	6	\$9.99	RT-6BT

## Van Norman, Peterson or Kansas Instruments OE Catspaw Screws For 777S or PK-447S & 944S



Description	Jobber	Order No.
<b>Catspaw Screws (1 each)</b>		
For #1 Shoe (0.625"L)	\$8.99	800-114
For #2 Shoe (0.740"L)	8.99	800-115
For #3, 4 & 5 Shoe (0.940"L)	8.99	800-116

# Cylinder Boring & Honing

CYLINDER HEAD REBUILDING ASSEMBLY & SAFETY CLEANING SHORT BLOCK REBUILDING CRANKSHAFT/ FLYWHEEL GRINDING TOOLS & SUPPLIES MISCELLANEOUS BRAKE & TIRE CHANGING TOOLS MEASURING TOOLS V-TWIN & METRIC HARD PARTS

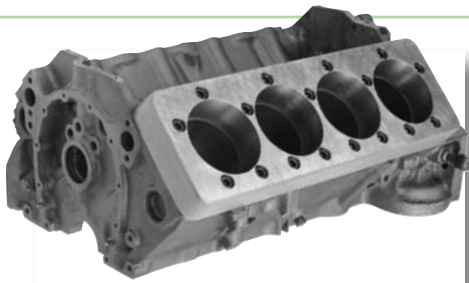

## tech tips

from the techxperts™

Head-bolt torque can distort cylinders as much as .004". If you bore and hone a cylinder without using a torque plate, expect up to this much head distortion. Torque plates create head-bolt stress and draw cylinders into their operating shape for boring or honing. Torque plates help you rebuild your block properly with greater precision. Bore hole size is .080" over standard bore size.

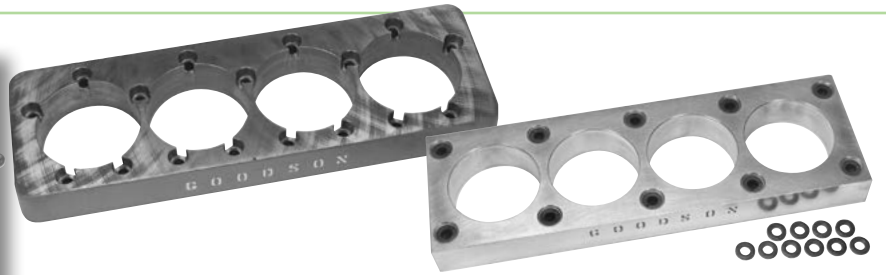

## Torque Plates for Use with a Portable Bar

- Genuine BHJ Torque Plates modified to GOODSON specifications
- Parallel blanchard ground • Heat-treated • Bolts included (unless noted)
- Bore size is .080" over standard bore size
- Visit [goodson.com](http://goodson.com) for individual torques plate photos

Fits	Displacement	Material	Bolts	Jobber	Order No.
<b>Chevy – with Cap-Screw Bolts for tight clearances</b>					
V8 Small Block	265-350	Cast Iron	✓	\$394.99	HGM-1
V8 Small Block	400	Cast Iron	.060" over standard bore	399.99	HGM-1A
<b>Chevy – use your existing fasteners (washers / spacers provided)</b>					
LS-1	350	Billet Alum.		\$589.99	HGM-LS1
Big Block Bowtie	(for bores up to 4.530")	Cast Iron		599.99	HCH-3-R-S
<b>Chrysler</b>					
V8 Small Block	273-360	Cast Iron	✓	\$399.99	HCR-4
V8 Big Block	361-440	Cast Iron	✓	449.99	HCR-6
<b>Ford</b>					
V8 Small Block	260-302	Cast Iron	7/16"	\$399.99	HFO-7
	351-400		1/2"		
V8 Big Block	429-460	Cast Iron	✓	449.99	HFO-9A

✓ Replacement Bolts and Washers are available

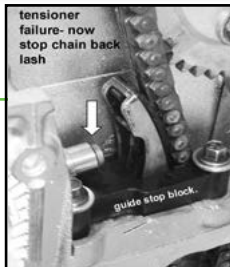

## Tensioner Stop Block for Chrysler 2.7 DOHC

- Eliminate broken timing chains, bent valves and chain backlash
- For VIN code R, U & V
- Mechanically supports hydraulic adjusters
- Use with plunger screw or bottom plate tensioners

Application	Jobber	Order No.
For New Chain & Tensioner	\$29.99	DT-27
For Used Chain (modifications may be required)	29.99	DT-27U



## Diamond Laps & Accessories for Rottler

- A light lap oil coat cools and lubricates
- Remove build-up with lint-free cloth and Dressing Stick while lap rotates

Machine	OD	ID	Jobber	Order No.
Rottler	1 3/4"	1/4"	\$188.99	LP-RFA
<b>Accessories</b>				
Very Fine Lap Oil (4 fl. oz.)			\$10.49	LP-LO-4
Very Fine Lap Oil (8 fl. oz.)			17.99	LP-LO-8
Dressing Stick			9.49	LP-DS

Other Diamond Laps available by Special Order



## Boring Bar O-Ring Cutter

### Replaceable Tool Bits & Holders

- Cut grooves for O-rings to enhance gasket sealing for high-performance engines • Machines a groove .037" wide

Description	Application	Lng.	Ht.	Jobber	Order No.
Holders	WVN, VN, Peterson, KI	3 3/8"	1 3/16"	\$157.99	VN-153
		1 5/8"	3/8"	144.99	VN-166
	Kwik-Way	2 1/8"	5/8"	119.99	KWL-156
		2 1/8"	5/8"	124.99	KWL-158
Tool Bits	Standard			67.99	KWVN-57
	Premium			76.99	KWVN-57C6

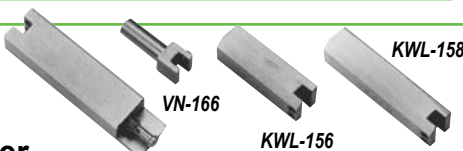

## special order

Other O-Ring Cutter Holders are available by Special Order

## tech tips

from the techxperts™  
To avoid breakage, use the standard cutter (KWVN-57) on cast iron blocks only and the Premium (KWVN-57C6) cutter on hard blocks. **CAUTION:** Avoid column drop as this will break the tips as well.

## 1 lb. Roll Copper or Stainless Steel O-Ring Wire

- Copper: .0403" dia.
- Stainless: .0410" dia.

Description	Jobber	Order No.
Copper	\$79.99	OWC-0403
Stainless Steel	67.99	OWS-041



### tech tips

from the techxperts™

- 1 - Extend the range of your hone with the Master Holder and Stone Supports on the bottom of page 77
- 2 - Use with 1/2" non-pistol grip drill
- 3 - Heavy Duty units can also be used in manual hone cabinets

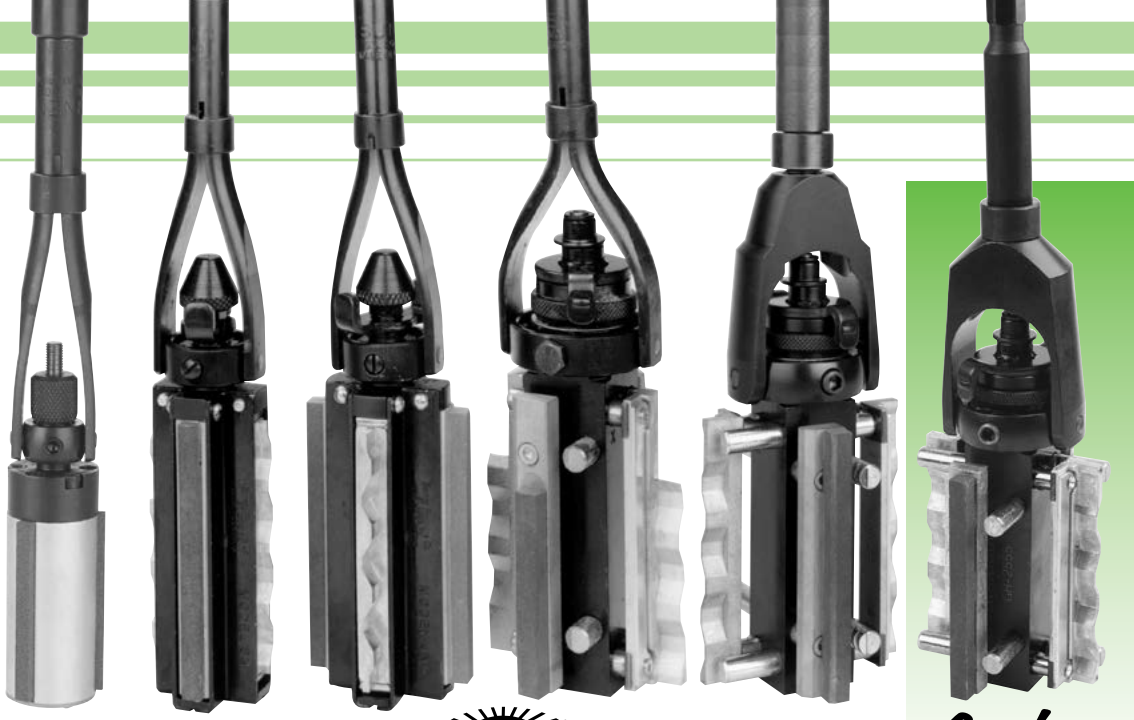

## Portable Cylinder Hone Mandrels (stones sold separately)

	Junior Midget	Midget	Junior	Standard	Heavy-Duty	Heavy-Duty
Brand	Sunnen®	Sunnen®	Sunnen®	Sunnen®	Sunnen®	Goodson
Honing Range	1.25" - 1.75"	1.75" - 2.00"	2.00" - 2.60"	2.50" - 5.50"	2.50" - 5.50"	2.50" - 5.50"
Drive Shank	2.00"	2.00"	2.00"	2.00"	2.00"	2.00"
Drive Extension	12.00"	12.00"	12.00"	12.00"	12.00"	12.00"
Thread	7/16" - 14	7/16" - 14	7/16" - 14	7/16" - 14	3/8" - 11	3/8" - 11
Order No.	<b>SNJ-10</b>	<b>SN-75</b>	<b>JN-95</b>	<b>AN-112</b>	<b>AN-815</b>	<b>GH-2555</b>
Jobber	\$594.81	\$475.85	\$473.79	\$499.97	\$671.99	\$549.99

NOTE: Goodson is only authorized to ship Sunnen® products within the Western Hemisphere

## One-Set Hone Stop Assembly

- Stop-collar meets the deck, preventing the hone from hitting webs and damaging stones or block
- Use full, even strokes to avoid cylinder taper
- Hardened brass thrust bushing
- Includes nylon stop collar
- Set the depth once for faster manual honing



Bushing ID	Jobber	Order No.
1/2" (12.7mm)	\$139.99	<b>HS-150-1/2</b>
5/8" (15.9mm)	139.99	<b>HS-150-5/8</b>
Replacement 5" Diameter Nylon Stop Collar	49.99	<b>HS-RING</b>

## Honing Stones

- Sets take 2 holders with 4" integral stones
- and 2 holders with aluminum wipers
- Ideal for Cast Iron



Grit	Range	mm	Finish	Sunnen	Jobber	Order No.
<b>For Sunnen® Junior Midget Hone (SNJ-10)</b>						
150 Grit	1.25" - 1.44"	31.8-36.6	45 Ra	—	\$30.17	<b>SNJ1-J45</b>
	1.42" - 1.60"	36.1-40.6	45 Ra	—	30.17	<b>SNJ2-J45</b>
	1.58" - 1.77"	40.1-44.9	45 Ra	—	30.17	<b>SNJ3-J45</b>
400 Grit	1.25" - 1.44"	31.8-36.6	8 Ra	—	30.17	<b>SNJ1-J87</b>
	1.42" - 1.60"	36.1-40.6	8 Ra	—	30.17	<b>SNJ2-J87</b>
	1.58" - 1.77"	40.1-44.9	8 Ra	—	30.17	<b>SNJ3-J87</b>
<b>For Sunnen® Midget Hone (SN-75)</b>						
70 Grit	1.75" - 2.00"	44.5-50.8	120 Ra	S18-J17	\$25.53	<b>SN-100</b>
150 Grit	1.75" - 2.00"	44.5-50.8	45 Ra	S18-J45	25.53	<b>SN-200</b>
220 Grit	1.75" - 2.00"	44.5-50.8	32 Ra	S18-J55	25.53	<b>SN-300</b>
280 Grit	1.75" - 2.00"	44.5-50.8	20 Ra	S18-J65	25.53	<b>SN-500</b>
400 Grit	1.75" - 2.00"	44.5-50.8	8 Ra	—	25.53	<b>S18-J87</b>
<b>For Sunnen® Junior Hone (JN-95)</b>						
70 Grit	2.00" - 2.20"	50.8-55.9	120 Ra	T20-J17	\$25.53	<b>JN-100</b>
	2.20" - 2.40"	55.9-60.9	120 Ra	U22-J17	25.53	<b>JN-101</b>
	2.40" - 2.60"	60.9-66.0	120 Ra	V24-J17	25.53	<b>JN-102</b>
150 Grit	2.00" - 2.20"	50.8-55.9	45 Ra	S20-J45	25.53	<b>JN-200</b>
	2.20" - 2.40"	55.9-60.9	45 Ra	U22-J45	25.53	<b>JN-201</b>
	2.40" - 2.60"	60.9-66.0	45 Ra	V24-J45	25.53	<b>JN-202</b>
220 Grit	2.00" - 2.20"	50.8-55.9	32 Ra	T20-J65	25.53	<b>JN-300</b>
	2.20" - 2.40"	55.9-60.9	32 Ra	U22-J55	25.53	<b>JN-301</b>
	2.40" - 2.60"	60.9-66.0	20 Ra	V24-J65	25.53	<b>JN-502</b>
280 Grit	2.00" - 2.20"	50.8-55.9	20 Ra	T20-J65	25.53	<b>JN-500</b>
	2.20" - 2.40"	55.9-60.9	20 Ra	U22-J65	25.53	<b>JN-501</b>
	2.40" - 2.60"	60.9-66.0	20 Ra	V24-J65	25.53	<b>JN-502</b>
400 Grit	2.00" - 2.20"	50.8-55.9	8 Ra	—	28.62	<b>T20-J87</b>
	2.20" - 2.40"	55.9-60.9	8 Ra	—	25.53	<b>U22-J87</b>
	2.40" - 2.60"	60.9-66.0	8 Ra	—	25.74	<b>V24-J87</b>

## Clear Honing Oil

- Helps keep stones clean and free-cutting
- Ideal for portable hones and all makes of automotive honing machines
- Mixes easily with other brands, including Sunnen®
- Not water soluble



Size	Jobber	Order No.
1 gal./3.78L	\$ 26.99	<b>HO-10</b>
5 gal./18.9L	114.99	<b>HO-50</b>



# American Made

## Goodson and Sunnen® Cylinder Honing Stones For all popular AN-style Hones and Hone Bodies

- Integral holder type sets have 4 pieces: 2 holders with stones and 2 holders with aluminum wipers • Fit Sunnen® AN Standard, AN Heavy-Duty and Goodson **GH-2555** hones • Use with honing oil
- Stones for Short or Blind Holes are 2<sup>13</sup>/<sub>16</sub>" long; All other stones are 4" long

Grit	Bore Range		Usage	Finish	SUNNEN®			GOODSON		
	in	mm			Jobber	Order No.	Sunnen No.	Jobber	Order No.	
70 Grit Roughing	2.5"-2.7"	63.5-68.6	Cast Iron	120 Ra	\$26.29	AN-115	G25-J17	\$24.99	HN-115S	
	2.7"-4.1"	68.6-104.1	Cast Iron	120 Ra	26.29	AN-100	M27-J17	24.99	HN-100S	
			Cast Iron	120 Ra	—	—	—	24.99	HN-100R <sup>1</sup>	
			Short/Blind	120 Ra	28.99	AN-100-71	M27-J17-71	24.99	HN-102S	
	3.5"-5.5"	88.9-139.7	Harley / VW	120 Ra	37.79	AN-100F	M27-J17	24.99	HN-100F	
			Cast Iron	120 Ra	26.29	AN-101	N37-J17	24.99	HN-101S	
			Cast Iron	120 Ra	—	—	—	24.99	HN-101R <sup>1</sup>	
	4.7"-15.0"	119.4-381	Short/Blind	120 Ra	29.79	AN-101-71	N37-J17-71	24.99	HN-104S	
			Hard Sleeves	55 Ra	26.29	AN-131	N37-J11	24.99	HN-131S	
			Cast Iron	120 Ra	26.29	AN-106	W47-J17	24.99	HN-106S	
Use Master Holder & Sleeve Support			Hard Sleeves	55 Ra	26.29	AN-136	W47-J11	24.99	HN-136S	
150 Grit Medium	2.5"-2.7"	63.5-68.6	Cast Iron	45 Ra	26.29	AN-215	G25-J45	24.99	HN-215S	
	2.7"-4.1"	68.6-104.1	Cast Iron	45 Ra	26.29	AN-200	M27-J45	24.99	HN-200S	
			Short/Blind	45 Ra	26.29	AN-200-71	M27-J45-71	24.99	HN-202S	
			Hard Sleeves	30 Ra	—	—	—	24.99	HN-230S	
	3.5"-5.5"	88.9-139.7	Cast Iron	45 Ra	26.29	AN-201	N37-J45	24.99	HN-201S	
			Short/Blind	45 Ra	29.79	AN-201-71	N37-J45-71	24.99	HN-204S	
			Hard Sleeves	30 Ra	26.29	AN-231	N37-J43	24.99	HN-231S	
	4.7"-15.0"	119.4-381.0	Cast Iron	45 Ra	26.29	AN-206	W47-J45	24.99	HN-206S	
			Hard Sleeves	30 Ra	27.29	AN-236	W47-J43	24.99	HN-236S	
			Cast Iron	32 Ra	26.29	AN-300	M27-J55	24.99	HN-300S	
Use Master Holder & Sleeve Support			Short/Blind	32 Ra	28.99	AN-300-71	M27-J55-71	24.99	HN-302S	
220 Grit Finishing	2.7"-4.1"	68.6-104.1	Cast Iron	32 Ra	26.29	AN-301	N37-J55	24.99	HN-301S	
	3.5"-5.5"	88.9-139.7	Short/Blind	32 Ra	28.99	AN-301-71	N37-J55-71	24.99	HN-304S	
			Cast Iron	32 Ra	26.29	AN-306	W47-J55	24.99	HN-306S	
			Short/Blind	32 Ra	28.99	AN-306-71	W47-J55-71	24.99	HN-306S	
	4.7"-15.0"	119.4-381	Cast Iron	32 Ra	26.29	AN-306	W47-J55	24.99	HN-306S	
			Short/Blind	32 Ra	28.99	AN-306-71	W47-J55-71	24.99	HN-306S	
			Hard Sleeves	12 Ra	—	—	—	24.99	HN-531S	
	Use Master Holder & Sleeve Support			Hard Sleeves	12 Ra	27.29	AN-536	W47-J63	24.99	HN-536S
	280 Grit Fine Finish	2.5"-2.7"	63.5-68.6	Cast Iron	20 Ra	26.29	AN-515	G25-J65	24.99	HN-515S
		2.7"-4.1"	68.6-104.1	Cast Iron	20 Ra	26.29	AN-500	M27-J65	24.99	HN-500S
Short/Blind				20 Ra	27.99	AN-500-71	M27-J65-71	24.99	HN-502S	
Hard Sleeves				12 Ra	26.29	AN-530	M27-J63	24.99	HN-530S	
3.5"-5.5"		88.9-139.7	Cast Iron	20 Ra	26.29	AN-501	N37-J65	24.99	HN-501S	
			Short/Blind	20 Ra	29.49	AN-501-71	N37-J65-71	24.99	HN-504S	
			Hard Sleeves	12 Ra	—	—	—	24.99	HN-531S	
4.7"-15.0"		119.4-381.0	Hard Sleeves	12 Ra	27.29	AN-536	W47-J63	24.99	HN-536S	
			Cast Iron	20 Ra	26.29	AN-506	W47-J65	24.99	HN-506S	
			Cast Iron	8 Ra	26.29	G25-J87	G25-J87	24.99	HN-615S	
400 Grit Extra Fine Finish	2.5"-2.7"	63.5-68.6	Cast Iron	8 Ra	26.29	G25-J87	G25-J87	24.99	HN-615S	
	2.7"-4.1"	68.6-104.1	Cast Iron	8 Ra	27.08	M27-J87	M27-J87	24.99	HN-600S	
			Hard Sleeves	5 Ra	27.08	M27-J85	M27-J85	24.99	HN-630S	
			Cast Iron	8 Ra	28.11	N37-J87	N37-J87	24.99	HN-601S	
	3.5"-5.5"	88.9-139.7	Hard Sleeves	5 Ra	28.11	N37-J85	N37-J85	24.99	HN-631S	
			Cast Iron*	2-3 Ra	32.79	G25-C05	G25-C05	—	—	
			Cast Iron*	2-3 Ra	60.04	MM33-C05	MM33-C05	—	—	
	Cork Polishing	2.5"-3.3"	63.5-83.8	Cast Iron*	2-3 Ra	32.79	G25-C05	G25-C05	—	—
		3.3"-4.2"	83.8-106.7	Cast Iron*	2-3 Ra	60.04	MM33-C05	MM33-C05	—	—
	Cork Polishing	4.0"-5.6"	101.6-142.2	Cast Iron*	2-3 Ra	46.34	NN40-C05	NN40-C05	—	—

(\*Cast Iron – 3 Ra., Hard Sleeves – 2 Ra., Steel– 3 Ra.)

<sup>1</sup>Ruby Aluminum-Oxide abrasive for longer life in rough cutting use



### Master Holder & Stone Supports

- Holds one 4" stone set
- Stones sold separately
- AN-365 requires use of AN-260

#### Master Holder

Dia. Range	Jobber	Order No.
4.7"-7.0"	\$125.49	AN-355
6.0"-9.0"	129.99	AN-365

#### Stone Supports for AN-365

6.0"-9.0"	\$91.32	AN-260
-----------	---------	--------

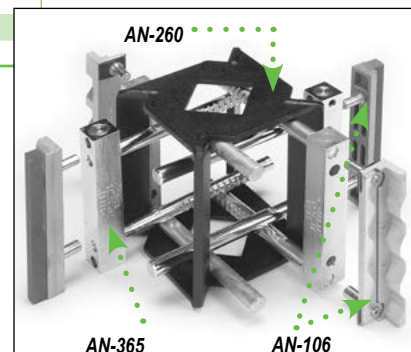

The more you buy, the more you save!  
Order 5 or more GOODSON HN Stones, save 10% off jobber



CYLINDER HEAD  
REBUILDING  
CLEANING,  
ASSEMBLY & SAFETY  
SHORT BLOCK  
REBUILDING  
CRANKSHAFT/  
FLYWHEEL GRINDING  
TOOLS & SUPPLIES  
MISCELLANEOUS  
BRAKE & TIRE  
CHANGING TOOLS  
MEASURING  
TOOLS  
V-TWIN & METRIC  
HARD PARTS



"Turn to the Goodson website to find information and place orders from anywhere at any time. And be sure to follow us on Facebook and Twitter!"  
- Crystal, Advertising Department, 2 years of service

CYLINDER HEAD REBUILDING  
CLEANING, ASSEMBLY & SAFETY  
SHORT BLOCK REBUILDING  
CRANKSHAFT/ FLYWHEEL GRINDING  
MISCELLANEOUS TOOLS & SUPPLIES  
BRAKE & TIRE CHANGING TOOLS  
MEASURING TOOLS  
V-TWIN & METRIC HARD PARTS

## Keyway Honing Stone Sets

- Two-stroke engines have intake and exhaust ports that interrupt the operation of your honing stone
- These stones allow the hone to pass the intake and exhaust ports while maintaining consistent pressure to remove material accurately and easily
- Use with any AN- or GH-series hone (p. 76)
- For Cast Iron

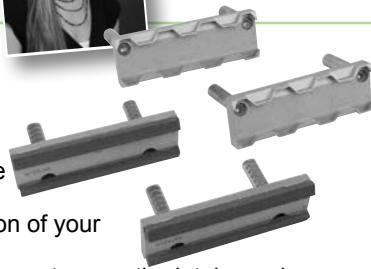

Grit	Range	mm	Finish	Jobber	Order No.
150 Grit	2.5" - 3.3"	63.5-83.8	45 Ra	\$49.49	GY25-J45
Medium	3.3" - 4.2"	83.8-106.7	45 Ra	48.40	MY33-J45
280 Grit	2.5" - 3.3"	63.5-83.8	20 Ra	49.49	GY25-J65
Fine Finish	3.3" - 4.2"	83.8-106.7	20 Ra	48.40	MY33-J65
400 Grit	2.5" - 3.3"	63.5-83.8	8 Ra	49.49	GY25-J85
Extra Fine	3.3" - 4.2"	83.8-106.7	8 Ra	48.40	MY33-J85

**EHU**  
type stones

**GEHN** type stones



## Stones & Shoes for Sunnen Hone Machines

- Premium-quality replacements for all CV-616, and CK-10 hones equipped with Sunnen® Master Holder Sets
- Diameter Range: 4.125" - 5.000"/ 104.8 - 127.0mm
- Use with Master Holder Set CK-3045A (sold separately)
- 2 stones per set

Stones			Goodson - 1 set		Sunnen - 6 sets	
Use	Grit	Finish	Jobber	Order No.	Jobber	Order No.
Hard Blocks	70	60 Ra	\$13.79	GEHN-116	\$83.49	EHN-116
Air Cooled Cyl.	70	60 Ra	13.79	GEHN-123	92.79	EHN-123
Hard Blocks	220	22-32 Ra	13.79	GEHN-512	92.79	EHN-512
Air Cooled Cyl.	220	22-32 Ra	13.79	GEHN-518	88.99	EHN-518
Hard Blocks	70	60 Ra	13.79	GEHU-123	78.49	EHU-123
Roughing	70	60 Ra	13.79	GEHU-133	78.49	EHU-133
Hard Blocks	220	22-32 Ra	13.79	GEHU-518	78.49	EHU-518
Gen. Purp.	220	22-32 Ra	13.79	GEHU-525	78.49	EHU-525
Aluminum	220	30-36 Ra	13.79	GJHU-525	80.84	JHU-525
High Nickel	280	20-25 Ra	13.79	GJHU-623	80.84	JHU-623
Finishing	280	16-23 Ra	13.79	GJHU-625	80.84	JHU-625
High Nickel	400	7-14 Ra	13.79	GJHU-818	80.84	JHU-818
Aluminum	400	7-14 Ra	13.79	GJHU-820	80.84	JHU-820
Accessories			Qty.	Jobber	Order No.	
Sunnen® Master Holder Set			1	\$256.79	CK-3045A	
Sunnen® Centering Guide (includes CK-3070)			1	109.99	CK-3090A	
Sunnen® Guide Shoe & Screw Set			1	17.99	CK-3070	
Wear Shoe			2	32.99	C-3070K	
Stabilizing Shoe			2	27.99	C-3120K	

For Rod Honing Stones and Shoes see page 83



## Sunnen® Tooling for Honing Dart Blocks & Ductile Sleeves

- Recommended for Dart™ Machinery
- Use with Sulfurated Rod Honing Oil (RHO-10 or RHO-50, p. 73) for all stone applications below

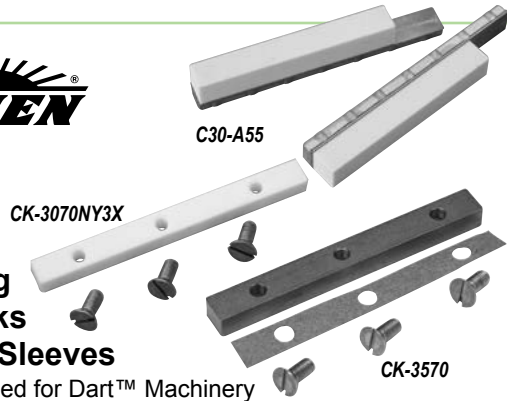

Description	Jobber	Order No.
<b>Honing Stone Sets For Portable Tooling</b>		
80 Grit	\$27.08	N37-A25
220 Grit	27.08	N37-A55
280 Grit	26.29	AN-501
400 Grit	39.95	MM33-J85
<b>For CK/CV Type Machines</b>		
80 Grit Stone Set (6)	\$ 91.79	C30-A25
150 Grit Stone Set (6)	91.79	C30-A45
220 Grit Stone Set (6)	91.79	C30-A55
280 Grit Stone Set (6)	91.79	C30-J65
400 Grit Stone Set (6)	91.79	C30-J85
Hardened Steel Guide Shoe (1)	150.29	CK-3570
Delron Guide Shoe (1)	114.79	CK-3070NY3X

**tech tips** For CK & CV Machines, **DO NOT** use Bronze Guide Shoes, use from the Techexperts™ Hardened Steel and Delron shoes above (1 of each)

Achieving a plateaued cylinder is a multi-step process. One that is far too detailed for the small space available here. Read more about this process on the Goodson Blog. Look for **Plateau Honing 101** or scan the code at right with your smart phone for direct access.



C30-PHT-731



## Ultra-Finish Plateau Hones

- For Portable Hones, Hone Cabinets and CV/CK Tooling
- Abrasive impregnated nylon bristles
- Ideal for high-performance rebuilding and rebuilding newer style engines that use low-tension rings
- Superior plateau finish so rings will seal immediately
- Reduces break-in time
- Allows closer tolerances for improved compression, better oil control, lower emissions
- Fits AN- or GH-series honers

<b>For Portable Hones and Hone Cabinets - Includes 1 pair</b>			
AN/ GH-Style	3.78" - 4.68"	96.0 - 118.9	\$284.06 <b>MM-PHT-731</b>
<b>For Sunnen CV / CK Hone Heads - Includes 1 pair</b>			
Standard	3.10" - 5.00"	78.7-127.0	\$169.99 <b>C30-PHT-731</b>

For the best possible finish, use a Hone Stop (page 76)

# Cylinder Boring & Honing

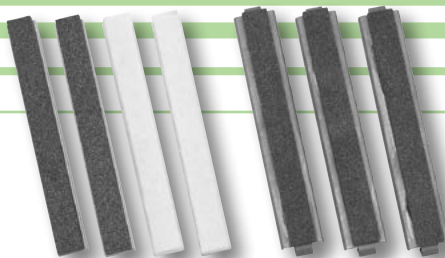

## Original Ammco Honing Stone Sets

### For Ammco 500 Hones

- Includes 2 stones and 2 felt wipers
- Use dry for best performance
- ½"W x 4"L

Grit	Qty	OE #	Order No.
60	4	#619	AHS-70
220	4	#620	AHS-220
320	4	#3933	AHS-280
400	4	#621	AHS-400

Jobber \$71.99

### For Ammco 3800 Hones

- Includes 3 stones
- Use liberal amounts of honing oil
- Clip on • ¾"W x 4"L

Grit	Qty	OE #	Order No.
100	3	#4040	AHS-110
180	3	#3840	AHS-111
280	3	#3810	AHS-112
400	3	#3833	AHS-113

Jobber \$57.99

## Lisle® Honing Stone Sets

- Clip-on style mounts in seconds
- 5"/127mm long stones and wipers
- Each set contains two stones and two felt wipers
- Use dry

Replaces Lisle® No.	Grit	Order No.
15500	80	HL-80
15510	180	HL-180
15520	280	HL-280
15590	500	HL-500

Jobber \$15.99 per set

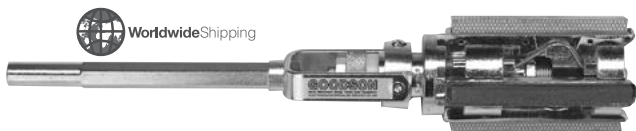
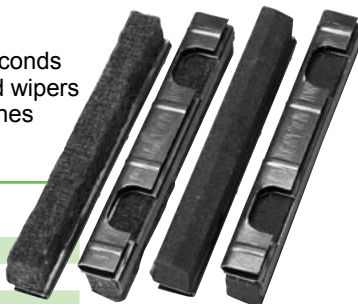

## Lisle® Small Diameter Portable Honing Set

- Precision built specifically for 1.75" to 2.75" diameter cylinders • Stones measure 3½"L (88.9mm)
- Set includes Hone plus 3 Sets of 180 grit Stones to fit full range (one set shown installed on hone), Allen wrench and Storage Case
- Order No. HL-1600 Jobber \$219.99

### Replacement Stone & Wiper Sets

- Includes 2 stones & felt wipers • Choose from grits below

Range		80 Grit	180 Grit	280 Grit
in.	mm	Order No.	Order No.	Order No.
1.75" - 2.20"	44.5 - 55.8	HL-1644	HL-1641	HL-1638
2.05" - 2.50"	51.4 - 63.5	HL-1645	HL-1642	HL-1639
2.35" - 2.75"	59.7 - 69.8	HL-1646	HL-1643	HL-1640
Jobber		\$19.99	\$19.99	\$19.99

Order 5 or more cones, save 10% off jobber



## 82° 3" Dia. Chamfering Cones & Mandrel

- Chamfer sharp edges for safe piston and ring installation • Handles all diameter cylinders or sleeves
- 82° abrasive cones measure 3½"/88.9mm high with 2"/50.8mm base and 3"/76.2mm top diameter
- Fits ⅝"/9.53mm or larger drill • Kit (CC-100) includes mandrel and three 50 Grit Aluminum Oxide cones (CC-15)
- Due to manufacturing process, abrasive color may vary

Description	Jobber	Order No.	Incl.
<b>3" Top Dia. Chamfering Cone Kit</b>	\$55.79	CC-100	▼
Replacement ⅝" Drill Adaptor	14.29	CC-100-1	x
<b>Aluminum Oxide Chamfering Cones (red)</b>			
40 Grit	\$8.49	CC-14	
50 Grit	8.49	CC-15	x
80 Grit	8.49	CC-20	
<b>Premium Zirconia Chamfering Cones (blue)</b>			
50 Grit	\$9.49	CCZ-15	
80 Grit	9.49	CCZ-20	

Order 5 or more cones, save 10% off jobber



## 45° 5"/127mm dia. Chamfering Cones & Mandrel

- Large diameter cones chamfer the top of the cylinder to an exact 45° angle in one pass
- ½"/12.7mm steel shank permanently embedded in the base
- Cone height: 3½"/88.9mm
- Kit includes mandrel & one 36-grit cone (CC-30)
- Due to manufacturing process, abrasive color may vary

Description	Jobber	Order No.	Incl.
<b>5" Chamfering Cone Kit</b>	\$120.79	CC-130	▼
<b>Chamfering Cones</b>			
Abrasive	Grit		
Aluminum Oxide (red)	36	\$8.49	CC-30
	50	8.49	CC-50
	80	8.49	CC-80
Premium Zirconia (blue)	36	10.49	CCZ-36
	50	10.49	CCZ-50
	80	10.49	CCZ-80

## Clear Honing Oil

- Helps keep stones clean and free-cutting
- Ideal for portable hones and all makes of automotive honing machines
- Mixes easily with other brands, including Sunnen®
- Not water soluble

Size	Jobber	Order No.
1 gal./3.78L	\$ 26.99	HO-10
5 gal./18.9L	114.99	HO-50



CYLINDER HEAD REBUILDING  
CLEANING, ASSEMBLY & SAFETY  
SHORT BLOCK REBUILDING  
CRANK PULLERS  
CELLANEOUS TOOLS & SUPPLIES  
BRAKE & TIRE CHANGING TOOLS  
MEASURING TOOLS  
V-TWIN & METRIC HARD PARTS

# ... another satisfied customer

"Your company should hold a seminar on how to run a company. I received your products the day following my order. When ordering from other companies they tell me it'll be 2-4 weeks because they are busy. It's nice to have great service these days. Thank you and keep up the great work!"

- Ray Temple, Waupaca, Wisconsin, Goodson customer since 2009

CYLINDER HEAD REBUILDING  
CLEANING, ASSEMBLY & SAFETY  
SHORT BLOCK REBUILDING  
CRANKSHAFT/ FLYWHEEL GRINDING  
MISCELLANEOUS TOOLS & SUPPLIES  
BRAKE & TIRE CHANGING TOOLS  
MEASURING TOOLS  
V-TWIN & METRIC HARD PARTS

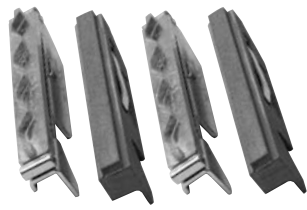

## Honing Stones for Nicasil

- Deglaze Nicasil cylinders with portable hones
- 150 Grit Aluminum-Oxide abrasive
- Resizing cylinders requires diamond abrasive
- Hones on page 76

Honing Stone Range	Jobber	Order No.
<b>SNJ-Style Hone</b>		
1.250" - 1.437" / 32 - 37mm	\$29.34	SNJ1-A43
1.418" - 1.604" / 36 - 41mm	29.34	SNJ2-A43
1.580" - 1.770" / 40 - 45mm	29.34	SNJ3-A43
<b>SN-Style Hone</b>		
1.550" - 2.000" / 44 - 51mm	\$29.34	S18-A43
<b>JN-Style Hone</b>		
2.000" - 2.200" / 51 - 56mm	\$28.62	T20-A43
2.200" - 2.400" / 56 - 61mm	29.34	U22-A43
2.400" - 2.600" / 61 - 66mm	25.74	V24-A43
<b>AN-Style Hones</b>		
2.500" - 3.300" / 64 - 84mm	\$38.99	GG25-A43
3.300" - 4.200" / 84 - 107mm	40.16	MM33-A43
4.000" - 5.600" / 102 - 142mm	40.16	NN40-A43

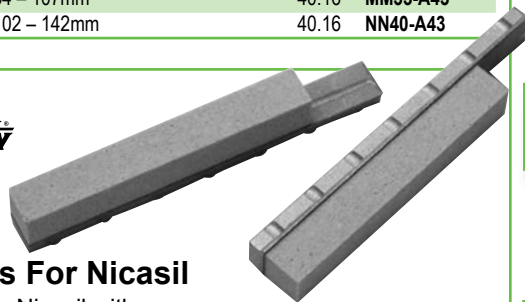

## Honing Stone Sets For Nicasil

- For deglazing Nicasil with a CV/CK Honing Machine
- Diameter Range:
  - 3.0" - 5.0" / 76.2-127.0mm in standard automotive head
  - 2.6" - 3.5" / 66.0-88.9mm in junior head
- 150 grit aluminum oxide abrasive
- 6 per set • Order No. **EHU-412** Jobber \$81.99

## 1" Thick Rod Hone Filter Mat

- Synthetic material
- Traps abrasive particles & metal filings BEFORE they enter the storage tank
- Cushions parts to prevent damage
- Replace when clogged
- 1"/25.4mm thick

Inches	Metric	Jobber	Order No.
18"x25"	45.7x63.5 cm	\$15.99	RH-MAT
26"x40"	66.0x101.6 cm	21.99	RH-MAT-2
33"x48"	83.8x121.9 cm	24.99	RH-MAT-3

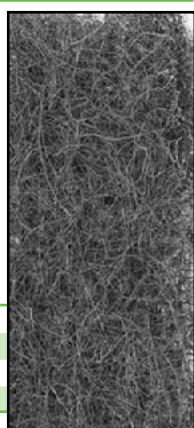

## tech tips

### from the techxperts™ Tips for Honing Nicasil

Nicasil is an electro-deposited (electroplated) composite of nickel and silicon carbide. Components are uniformly dispersed throughout the resulting material. Care must be used when honing this material as the plating is normally applied in thicknesses no greater than .003". If you remove too much of the Nicasil, you will need to have the cylinder bores replated. The wear ratio on Nicasil is 10:1 so .010" wear in a normal cylinder would be only .001" on Nicasil.

An aluminum-oxide abrasive is necessary for honing Nicasil as silicon-carbide is a part of the material and abrasives will not cut materials of similar density and composition.

We recommend using our Rod Honing Oil when working on Nicasil. The additives that make it ideal for high pressure honing also help the aluminum oxide abrasive cut cleaner and faster on a Nicasil surface.

If you have any other questions about honing Nicasil, be sure to call one of the Techxperts™ at Goodson 1-800-533-8010.



## Rod Honing Oil

- Includes additives for high pressure cutting
- Keeps stones clean and free-cutting during rod reconditioning, pin fitting and other honing applications
- Will mix with other honing oils (including Sunnen®)

Size	Jobber	Order No.
1 gal./3.78L	\$ 34.99	RHO-10
5 gal./18.9L	174.99	RHO-50

Order 3 or more Flex-Hones® (mix & match) and save 10% off jobber



## Standard Duty 240 Grit Aluminum Oxide Flex-Hones®

Inch	mm	Jobber	Order No.	Inch	mm	Jobber	Order No.
2¼"	57.2	\$35.29	BA-225240	3¼"	82.5	\$55.79	BA-325240
2⅝"	60.2	37.29	BA-237240	3½"	88.9	59.29	BA-350240
2½"	63.5	37.79	BA-250240	3¾"	95.3	63.79	BA-375240
2⅞"	66.5	40.49	BA-262240	4"	104.8	67.99	BA-418240
2¾"	69.8	42.49	BA-275240	4½"	117.5	75.79	BA-462240
3"	76.2	49.49	BA-300240	More Flex-Hones® on page 72			

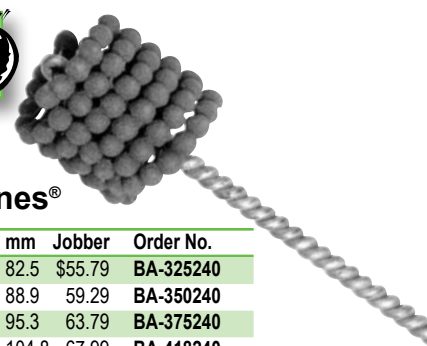

## Hone Cabinet Filter Paper

- Reduce sump and filter clean-up
- Extend oil life
- Filter paper in the bottom of hone machine removes debris before oil enters the sump
- When full, dispose of properly
- 2 - 60" x 60" sheets (trim to fit)
- Order No. **HN-FP** Jobber \$19.99

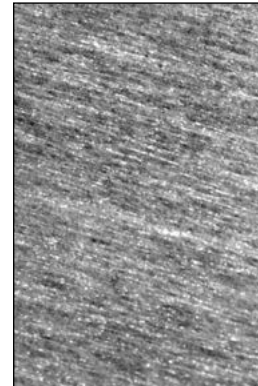

# Cylinder Boring & Honing



## Hone High-Silicon Aluminum Alloy Blocks With Ease – Honing Stones & Silicon Compound

- Stones fit both the Sunnen® AN-112 and AN-815 and the Goodson GH-2555 Portable Honing Mandrels
- Use each stone set progressively until the final bore size is achieved
- To create the final condition, coat the felt set and the honed cylinder surface with the Silicon Compound (AN-30) and lap the cylinders
- After completion, the cylinder will have a dull matte finish
- Piston and rings will ride on silicon instead of aluminum
- Silicon Compound 1 lb. / 450g

Description	Hone Dia. 2.5"-3.3"		Hone Dia. 3.3"-4.2"	
	Jobber	Order No.	Jobber	Order No.
Roughing (280 grit)	\$41.99	<a href="#">GG25-J65</a>	\$39.95	<a href="#">MM33-J63</a>
Finishing (400 grit)	41.99	<a href="#">GG25-J85</a>	39.95	<a href="#">MM33-J85</a>
Polishing (600 grit)	52.49	<a href="#">GG25-CO5</a>	60.04	<a href="#">MM33-CO5</a>
Felt Set	92.75	<a href="#">GG25-FO5</a>	64.88	<a href="#">MM33-FO5</a>
Silicon Compound	59.99	<a href="#">AN-30</a>	59.99	<a href="#">AN-30</a>



## Mandrel Driver for Portable Use of CR-, PL- and ML-Series Honers

- Ideal for spindle bushings mounted on axles and other jobs that can't be taken to the honing machine
- For holes 3/4"/19.05mm ID and larger, where length is at least 3 times the diameter
- ID Range: .744" - 3.875"/19mm - 98mm
- Graduated adjustment knob advances and retracts stones • 275 - 450 RPM range
- Use with any 1/2"/12.7mm drill or larger
- Order No. **GGN-150** Jobber \$719.99



## Mandrel Driver for Align Honing Machines

- For Sunnen® CH-100 & similar align honing machines
- Graduated adjustment knob advances and retracts honing stones
- Quick release lever allows hone removal and installation without resetting
- Stone pressure adjusts with dial
- Automatically advances stones during honing
- **NOT** for portable honing applications
- Order No. **CH-75A** Jobber \$999.99

## tech tips

*Right Hand Rotation Only.*

For best results, keep your RPM about the same from the techxperts™ as your hone RPM, use the same rate of speed and number of strokes per minute.

## Ultra-Finish Plateau Soft Hones

- Remove microscopic peaks and scuffs without enlarging bores • Use with a portable drill • Abrasive impregnated nylon bristles • Ideal for high-performance engine rebuilding and for newer style engines that use low-tension rings
- Use **after** honing
- Gives a superior plateau finish so rings seal immediately, reducing break-in time
- Small sizes ideal for valve guide work
- Allows closer tolerances for improved compression, better oil control, lower emissions
- For best results, use liberal amounts of honing oil (**HO-50**, pg. 73) • **NOT** interchangeable with Flex-Hones®

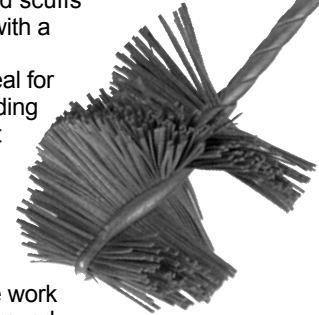

Hole Diameter in	Hole Diameter mm	Hone Dia. in	Hone Length in	Overall Length in	Jobber	Order No.
.2187"	5.5	.241"	1.00"	4.00"	\$ 9.79	<b>UF-5.5MM</b>
.2500"	6.4	.275"	1.25"	4.50"	9.79	<b>UF-6.4MM</b>
.2813"	7.0	.309"	1.25"	4.50"	10.99	<b>UF-7MM</b>
.3125"	8.0	.343"	1.25"	4.50"	10.99	<b>UF-8MM</b>
.3437"	9.0	.378"	1.25"	4.50"	10.99	<b>UF-9MM</b>
.3750"	10.0	.413"	1.25"	4.50"	10.99	<b>UF-10MM</b>
.4375"	11.0	.481"	1.25"	4.50"	10.99	<b>UF-11MM</b>
.4688"	12.0	.516"	1.25"	4.50"	10.99	<b>UF-12MM</b>
.5000"	13.0	.550"	1.50"	5.00"	12.29	<b>UF-13MM</b>
.5625"	14.0	.618"	1.50"	5.00"	12.29	<b>UF-14MM</b>
.6250"	16.0	.688"	1.50"	5.00"	12.29	<b>UF-16MM</b>
.6875"	17.5	.756"	1.50"	5.00"	12.29	<b>UF-17.5MM</b>
.7500"	19.0	.825"	1.50"	5.00"	12.29	<b>UF-19MM</b>
.8125"	20.5	.893"	1.50"	6.00"	12.29	<b>UF-20.5MM</b>
.875"-1.00"	22-25	1.250"	2.00"	10.00"	44.99	<b>UF-100</b>
1.00"-1.25"	25-32	1.500"	2.00"	10.00"	45.99	<b>UF-125</b>
1.25"-1.75"	32-45	2.000"	2.00"	10.00"	47.29	<b>UF-175</b>
1.75"-2.25"	45-57	2.500"	2.00"	10.00"	48.79	<b>UF-200</b>
2.25"-2.75"	57-70	3.000"	3.00"	10.00"	48.79	<b>UF-250</b>
2.50"-3.00"	63-76	3.500"	4.00"	14.00"	57.79	<b>UF-300</b>
3.00"-3.50"	76-89	4.000"	4.00"	14.00"	59.99	<b>UF-350</b>
3.50"-4.00"	89-102	4.500"	4.00"	14.00"	59.99	<b>UF-400</b>
4.00"-4.50"	102-114	5.000"	5.00"	14.00"	62.99	<b>UF-450</b>
4.50"-5.00"	114-127	5.500"	5.00"	14.00"	64.99	<b>UF-500</b> <small>NEW</small>



## Main Bore Align Hone Mandrels

- For the Sunnen® CH-100 Line Honing Machine
- Hone unit includes 1 set of 10 stones and 1 set of 20 shoes (replacement stones & shoes available)

Range	mm	Mandrels		Shoes (10/box)	
		Jobber	Order No.	Jobber	Order No.
2.4"-2.7"	61-69	\$2813.58	<b>10RY-2400G</b>	\$72.09	<b>RG-D</b>
2.7"-3.0"	69-77	2721.95	<b>10RY-2700G</b>	72.09	<b>RG-D</b>
3.0"-3.5"	77-89	3123.68	<b>10RY-3000H</b>	77.24	<b>RH-D</b>
Stones 5/box		\$82.39	<b>RY24-J49 (recommended for cast iron)</b>		
fit all mandrels above		82.39	<b>RY24-J45 (recommended for aluminum)</b>		

More stones and shoes are available by special order, call to inquire.

1-800-533-8010

CYLINDER HEAD REBUILDING ASSEMBLY & SAFETY CLEANING, SHORT BLOCK REBUILDING CRANKSHAFT/ FLYWHEEL GRINDING TOOLS & SUPPLIES MISCELLANEOUS BRAKE & TIRE CHANGING TOOLS MEASURING TOOLS V-TWIN & METRIC HARD PARTS

... another satisfied customer

"I bought your regular honing oil, and it does a fine job and it cuts well, however, when I found out the RHO honing oil might be a better deal, I began taking gallons of RHO honing oil and adding it to my tank to make it hone better, and sure enough I found that by adding the RHO honing oil the stones cut faster without clogging."

- George Livergood, Action Machine Shop, Goodson customer since 2010



## CR-Series Mandrels



- Recondition rods to factory specs
- Produces a round, straight rod bore for perfect bearing fit
- Mandrels include a wedge plate, wedge, tension block, shoe clamps and guide shoes (replacement parts available separately)
- Honing stones sold separately

### CR Series Mandrels

Inch	mm	Jobber	Order No.
1.45" - 1.60"	36.8 - 40.6	\$419.99	CR-1450
1.60" - 1.75"	40.6 - 44.4	419.99	CR-1600
1.75" - 1.90"	44.4 - 48.3	419.99	CR-1750
1.90" - 2.10"	48.3 - 53.3	451.49	CR-1900
2.10" - 2.30"	53.3 - 58.4	451.49	CR-2100
2.30" - 2.50"	58.4 - 63.5	451.49	CR-2300
2.50" - 2.70"	63.5 - 68.6	514.49	CR-2500
2.90" - 3.10"	73.7 - 78.5	587.99	CR-2900

### Rod Chamfer Cutters

Use in place of stone on CR-Mandrels to chamfer large ends

Fits CR-1450 to 1750	Cutter with tip	\$141.36	CR-35
Fits CR-1900 & larger	Cutter with tip	129.29	CR-25
Replacement 3-edge Carbide Tip		68.29	CR-28A

Larger Mandrels, Stones and Replacement Parts are available by Special Order. Call 1-800-533-8010 for details.

Stones

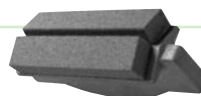

Guide Shoe



## Stones & Replacement Parts

### Honing Stones for Manual Honing\*

Fit Mandrels	Finish	Jobber	Sunnen Order No.	Jobber	Goodson Order No.
CR-1450 to 1750	Medium	\$24.29	CR-2	\$10.99	HC-2
	Fine	24.29	CR-4	10.99	HC-4
CR-1900 & Larger	Aluminum/ Titanium	24.29	CR-9	_____	_____
	Roughing	24.29	CR-10	11.79	HC-10
	Medium	24.29	CR-12	11.79	HC-12
	Fine	24.29	CR-14	11.79	HC-14
For Power Hone	Roughing	28.49	CR-10N	_____	_____

### Guide Shoes (2 per box)

CR-1450 to 1750	Die Cast	\$ 9.99	CR-40D	8.99	C-40D
CR-1900 & larger	Die Cast	12.99	CR-50D	10.79	C-50D
	Bronze	37.99	CR-50B	31.99	C-50-BR

### Wedge & Wedge Plates

CR-1450 to 1750	Wedge	\$60.99	CR-70	_____	_____
	Small Plate	28.99	CR-75	_____	_____
	Large Plate	28.99	CR-85	_____	_____
CR-1900 to 2500	Wedge	34.49	CR-100	_____	_____
CR-1900 & Larger	Small Plate	31.49	CR-110	_____	_____
	Large Plate	31.49	CR-120	_____	_____
CR-2900	Wedge	42.99	CR-200	_____	_____

Sunnen® Tension Block For CR-2900 & Larger \$14.20 LN-1337A

Sunnen® Shoe Clamps (4 + screws) for CR-1900 & larger 94.49 CR-45A

\*Sunnen® honing stones include 2/box, Goodson include 1/box



## Honing Head for Rod Machines

- For small engines & removable cylinders
- Accurate to .0005"
- Fits most popular rod honing machines
- Ideal for small engines or those with removable cylinders such as air-cooled VW or motorcycles
- Uses Goodson HN- or Sunnen® AN-style honing stones (pg. 77)
- Order No. **AN-600**  
Jobber \$999.99

Shown with optional honing stones

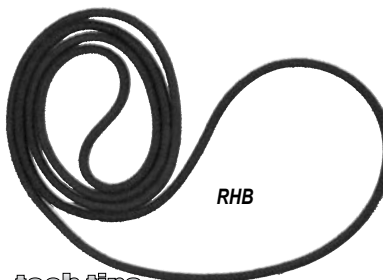

## Goodson Belts for Sunnen® Rod Honing Machines

- Top-quality belts for long life

### tech tips

from the techxperts™

You must measure the belt you are replacing. Ordering is based on length, not machine model. If your belt size doesn't match one in the chart, order the next size down. For example, if your belt measures 72 1/2", order the 70" Oil Pump Belt. Belts stretch over time so the shorter belt will fit.

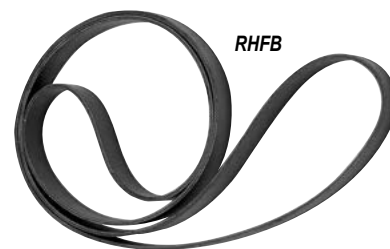

## Rod Honing Oil

- Includes additives for high pressure cutting
- Keeps stones clean and free-cutting during rod reconditioning, pin fitting and other honing applications
- Will mix with other honing oils (including Sunnen®)

Size	Jobber	Order No.
1 gal./3.78L	\$ 34.99	RHO-10
5 gal./18.9L	174.99	RHO-50

Size	Jobber	Order No.
<b>Oil Pump Belts (.250" diameter)</b>		
70"/1.78m	\$94.99	RHB-70
74"/1.88m	94.99	RHB-74
84"/2.13m	94.99	RHB-84
85"/2.16m	94.99	RHB-85
109"/2.77m	109.99	RHB-109
<b>Flat Belts</b>		
37 1/4" x 5/8"/945.9x15.9mm	\$ 99.99	RHFB-37
45 1/2" x 5/8"/1155.7x15.9mm	114.99	RHFB-45
46 1/2" x 5/8"/1181.1x15.9mm	114.99	RHFB-46

# Rod Honing Stones & Mandrels



## KL-Series Lifetime Honing Units For Connecting Rods (Pin Fitting)

- Replaceable shoe means the mandrel never wears out
- Stone & Shoe are of proper length to produce straight, round, accurate holes
- Choose stones from chart below
- Special orders are available, call **1-800-533-8010** for details

Adaptor

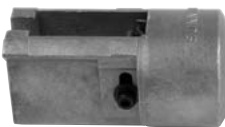

Mandrel includes 1 guide shoe



Truing Sleeve



Mandrel

**KL Mandrels** (Order Truing Sleeve, Adaptor & Hone Stones separately)

Range (in)	(mm)	Mandrel			Truing Sleeve		Adaptor		Guide Shoes (2)	
		Includes Wedge & 1 Guide Shoe	Jobber	Order No.	Sunnen® No.	Jobber	Order No.	Jobber	Order No.	Jobber
0.775"-0.805"	19.7 - 20.4	\$86.51	<b>KL-775M</b>	AK20-775UA	\$15.75	<b>S-775</b>	\$31.37	<b>AK20-A</b>	\$42.22	<b>UA-B</b>
0.838"-0.868"	21.3 - 22.0	86.51	<b>KL-838M</b>	AK20-838UB	16.78	<b>S-838</b>	31.37	<b>AK20-A</b>	42.22	<b>UB-B</b>
0.869"-0.899"	21.1 - 22.8	86.51	<b>KL-869M</b>	AK20-869UB	16.78	<b>S-869</b>	31.37	<b>AK20-A</b>	42.22	<b>UB-B</b>
0.900"-0.930"	22.1 - 23.6	86.51	<b>KL-900M</b>	AK20-900UC	16.78	<b>S-900</b>	31.37	<b>AK20-A</b>	42.73	<b>UC-B</b>
0.962"-0.993"	24.4 - 25.2	86.51	<b>KL-962M</b>	AK20-962UC	16.78	<b>S-962</b>	31.37	<b>AK20-A</b>	42.73	<b>UC-B</b>
0.994"-1.062"	25.2 - 27.0	97.32	<b>KL-1000M</b>	AK20-1000UD	16.78	<b>S-994</b>	31.37	<b>AK20-A</b>	42.73	<b>UD-B</b>
1.056"-1.125"	26.8 - 28.6	108.14	<b>KL-1062M</b>	AK20-1062UD	18.53	<b>S-1062</b>	31.37	<b>AK20-A</b>	42.73	<b>UD-B</b>
1.181"-1.250"	30.0 - 31.7	97.32	<b>KL-1187M</b>	AK20-1187UE	18.53	<b>S-1187</b>	31.37	<b>AK20-A</b>	43.04	<b>UE-B</b>

**NOTE:** Sunnen® has changed their part numbers. We have listed the Sunnen industrial number to the right of our order number for your convenience.



## Rod and Cap Grinding Wheels

- Recessed design
- Fits Sunnen® Rod and Cap Grinding Machines

Size	Jobber	Order No.
4"x1½"x1"	\$42.99	<b>GR-305</b>
101.6x38.1x25.4 mm		
6"x2"x1¼"	99.99	<b>GR-805</b>
152.4x50.8x31.8 mm		



## Delta Cap Cutter Premium Grinding Wheel

- Fits Delta Cap Cutter Model #6200XHD
- 7" OD x 1½" thick x 5½" ID
- Plate mounted & balanced for smooth grinding
- Ideal for welded main caps
- Order No. **GR-6200XHD**
- Jobber \$169.99

## Rod Honing Stones and Guide Shoes

- Premium-quality
- Choose Goodson or Sunnen®



Stones	Use	Goodson			Sunnen®		
		Jobber	Order No.	Qty.	Jobber	Order No.	Sunnen No.
<b>For Sunnen® SL720 - SL2300 Mandrel</b>							
	Roughing	\$11.29	<b>HS-5</b>	1	\$91.97	<b>SL-5</b>	6
	General Purpose	11.29	<b>HS-7</b>	1	91.97	<b>SL-7</b>	6
	Finishing	11.29	<b>HS-13</b>	1	91.97	<b>SL-13</b>	6
<b>For Sunnen® PL Series Mandrel</b>							
	Roughing	\$6.79	<b>HP-5</b>	1	\$80.12	<b>PL-5</b>	P28-J27 12
	General Purpose	6.79	<b>HP-7</b>	1	80.12	<b>PL-7</b>	P28-J47 12
	Finishing	6.79	<b>HP-13</b>	1	80.12	<b>PL-13</b>	P28-J67 12
<b>For Sunnen® ML Series Mandrel</b>							
	Roughing	\$6.29	<b>HM-5</b>	1	\$80.12	<b>ML-5</b>	P20-J25 12
	General Purpose	6.29	<b>HM-7</b>	1	80.12	<b>ML-7</b>	P20-J47 12
	Finishing	6.29	<b>HM-13</b>	1	80.12	<b>ML-13</b>	P20-J67 12
<b>For Sunnen® KL Series Mandrel</b>							
	Roughing	\$6.29	<b>HK-5</b>	1	\$80.12	<b>KL-5</b>	K20-J25 12
	General Purpose	6.29	<b>HK-7</b>	1	80.12	<b>KL-7</b>	K20-J47 12
	Finishing	6.29	<b>HK-13</b>	1	80.12	<b>KL-13</b>	K20-J67 12
	Steel	—	—	—	80.12	<b>KL-14</b>	K20-A69 12
<b>Bronze Guide Shoes</b>							
<b>For Sunnen® KL and ML Series Mandrel</b>							
	.775"-.805"	19.7-20.4mm	—	—	\$42.22	<b>UA-B</b>	2
	.838"-.899"	21.3-22.8mm	—	—	42.22	<b>UB-B</b>	2
	.900"-.993"	22.9-25.2mm	—	—	42.73	<b>UC-B</b>	2
	.994"-1.125"	25.2-28.6mm	—	—	42.73	<b>UD-B</b>	2
	1.119"-1.250"	28.4-31.8mm	—	—	43.04	<b>UE-B</b>	2
<b>Note:</b> Bronze guide shoes outlast die cast 6 to 1.							
<b>Zinc Alloy Guide Shoes</b>							
<b>For Sunnen® PL and ML Series Mandrel</b>							
	1.355" - 1.500"	34.4-38.1mm	—	—	\$19.56	<b>WC-D</b>	2
	1.480" - 1.625"	37.6- 41.3mm	—	—	19.56	<b>WD-D</b>	2

## Diamond Stone Dresser

- Diamond stone on durable metal tool
- Order No. **MAN-700**
- Jobber \$92.69

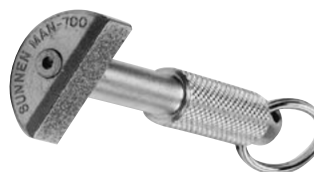

CYLINDER HEAD REBUILDING  
CLEANING, ASSEMBLY & SAFETY  
SHORT BLOCK REBUILDING  
CRANKSHAFT/ FLYWHEEL GRINDING TOOLS & SUPPLIES  
MISCELLANEOUS  
BRAKE & TIRE CHANGING TOOLS  
MEASURING TOOLS  
V-TWIN & METRIC HARD PARTS

... another satisfied customer

"This tool works!"

- Dennis Terrill, Terrill Motor Machine, Fort Lauderdale, FL, Goodson customer since 1990

CYLINDER HEAD REBUILDING  
CLEANING, ASSEMBLY & SAFETY  
SHORT BLOCK REBUILDING  
CRANKSHAFT/ FLYWHEEL GRINDING  
MISCELLANEOUS TOOLS & SUPPLIES  
BRAKE & TIRE CHANGING TOOLS  
MEASURING TOOLS  
V-TWIN & METRIC HARD PARTS



Standard Wrist Pin Bushing Driver sizes range from 25mm to 54mm. If we don't have the size you're looking for in the chart below, we can create special drivers. Call the Goodson Techxperts™ at 1-800-533-8010 for more information.

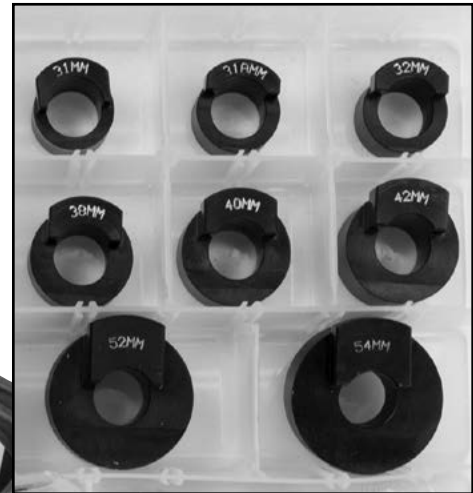

For easy identification, each Wrist Pin Bushing Drivers has the size stamped on it.

sized for diesel



American Made

## Universal Tapered Pin Bushing Press Kit For Light & Medium Duty Diesel Engines

This press kit is specially designed to remove and replace tapered bushings in most common light to medium duty diesel applications. Don't spend time making a fixture that's dedicated to a single size. Our Tapered Pin Bushing Press Kit is ready to go when you receive it. All you need is the correct bushing driver to get started.

### Choosing A Driver

1. Measure the wrist pin diameter.
2. Select a driver from the chart at right that is .030" to .040" smaller.
3. Measure the thickness of the bushing.
4. Select the driver with a Step size that is 50% to 60% of the bushing thickness.

tech tips  
from the techxperts™

EXAMPLE:

Wrist Pin Dia. 1.185"  
Nearest Driver Dia. 1.158"  
Bushing Thickness .150"  
40% of Thickness 0.090"

Select Bushing Driver TBD-31

If your measurements do not correspond to a driver in the chart, call 1-800-533-8010 to ask about a special order

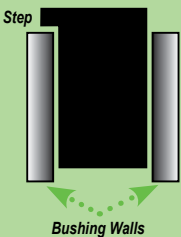

## tech tips

from the techxperts™  
When pressing together always press the rod onto the bushing and NOT the bushing into the rod. This prevents the bushing from collapsing or folding up.

Description	Jobber	Order No.	Incl.
Complete Wrist Pin Bushing Press Kit	\$1399.99	TB-KIT	▼
Wrist Pin Press Base (select drivers below)	749.99	TB-BASE	▼
Press Tube - Small (27x21x120mm)	34.99	TPT-SM	x x
Press Tube - Large (30x31x110mm)	34.99	TPT-LG	x x
Wrist Pin Ring (50x5x20/26mm)	15.99	WPR-001	x x
Wrist Pin Parallels (2) 8x10x50mm	27.99	WPP-2	x x
Extended Mandrel (8 1/2" long)	89.99	TB-MANDREL	x x

### Wrist Pin Bushing Drivers sold by dimension, not application

MM	Nominal	Actual	Step	Jobber	Order No.	Incl.
25	1.000"	0.957"	0.063"	\$59.99	TBD-25	x
26	1.063"	0.990"	0.058"	59.99	TBD-26	x
27	1.060"	1.032"	0.067"	59.99	TBD-27	x
28	1.100"	1.006"	0.055"	59.99	TBD-28	x
30	1.180"	1.102"	0.075"	59.99	TBD-30	x
31	1.220"	1.158"	0.090"	59.99	TBD-31	x
31	1.220"	1.198"	0.067"	59.99	TBD-31A	x
32	1.260"	1.222"	0.078"	59.99	TBD-32	x
33	1.300"	1.268"	0.068"	59.99	TBD-33	x
34	1.340"	1.304"	0.073"	59.99	TBD-34	x
36	1.420"	1.377"	0.075"	59.99	TBD-36	x
38	1.500"	1.458"	0.076"	59.99	TBD-38	x
40	1.570"	1.554"	0.068"	59.99	TBD-40	x
42	1.650"	1.614"	0.097"	59.99	TBD-42	x
45	1.770"	1.742"	0.089"	59.99	TBD-45	x
46	1.810"	1.772"	0.108"	59.99	TBD-46	x
50	1.970"	1.940"	0.083"	59.99	TBD-50	x
52	2.050"	2.012"	0.114"	59.99	TBD-52	x
54	2.130"	2.099"	0.081"	59.99	TBD-54	x

Press Fit Lube (6 oz. Aerosol can)

11.99 PFL-200\*

\*Hazardous Goods Fees Apply When Shipped Air

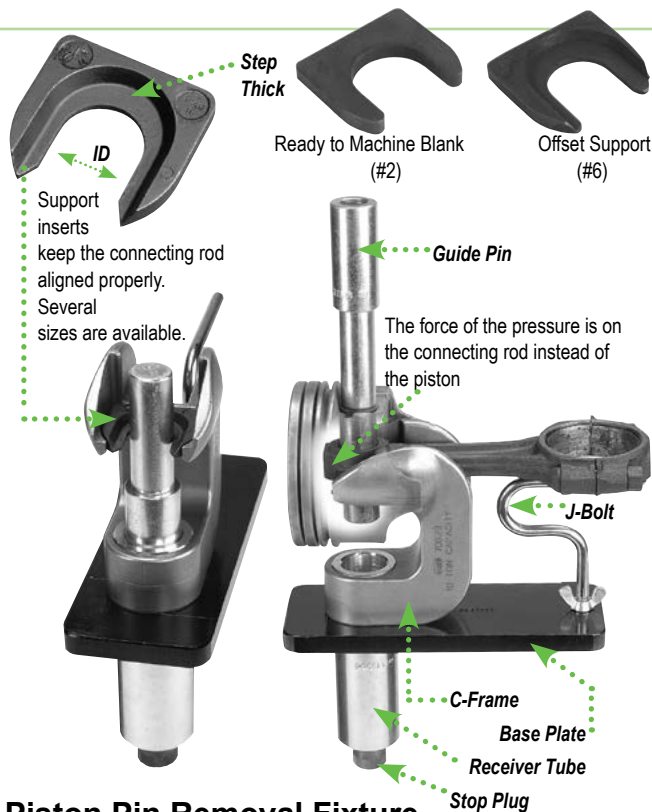

## Piston Pin Removal Fixture

- Use to remove or install interference fit piston pins
- Force of removal is against the piston pin and connection rod – no pressure is exerted on the piston itself
- Tool to fit most popular engines with pin diameters of 0.859" through 1.087"
- Replacement Support Inserts & Guide Pins sold separately

**tech tips** For Small Block Chevy use Support Insert #1 or Offset #6, for Big Block Chevy, use Support Insert #5, Support #2 is a blank, ready to be machined to your exact specifications.

Description	ID	Thick	Jobber	Order No.	Incl.
<b>Complete Kit</b>			\$999.99	<b>PPE-7082</b>	▼
<b>Replacement C-Frame</b>			339.99	<b>PPE-302186</b>	x
<b>Replacement Support Inserts</b>	#1	0.945" .100"	43.99	<b>PPE-39889</b>	x
	#2	1.110" .275"	43.99	<b>PPE-39890</b>	x
	#3	1.000" .182"	43.99	<b>PPE-39888</b>	x
	#4	1.110" .182"	43.99	<b>PPE-39886</b>	x
	#5	1.000" .100"	43.99	<b>PPE-39887</b>	x
	#6	0.945" .100"	43.99	<b>PPE-39822</b>	x
<b>Replacement Guide Pins</b>	0.859"		\$29.99	<b>PPE-17940</b>	x
	0.897"		29.99	<b>PPE-17936</b>	x
	0.926"		29.99	<b>PPE-17937</b>	x
	0.970"		29.99	<b>PPE-17938</b>	x
	0.992"		29.99	<b>PPE-17939</b>	x
	1.032"		29.99	<b>PPE-17941</b>	x
	1.055"		29.99	<b>PPE-17942</b>	x
	1.087"		29.99	<b>PPE-18729</b>	x
<b>Replacement Parts</b>					
J" Bolt (Rear Support)			\$25.99	<b>PPE-302224</b>	x
Wing Nut			1.29	<b>PPE-10588</b>	x
1½"/30.2mm Stop Plug			39.99	<b>PPE-17830D</b>	x
Base Plate			79.99	<b>PPE-17929</b>	x
Receiving Tube			49.99	<b>PPE-17931B</b>	x
Body Guide			41.99	<b>PPE-17932B</b>	x
5/2"/139.7mm Spring			7.79	<b>PPE-17934</b>	x
Drift Pin Driver			24.99	<b>PPE-17935</b>	x
1½"/41.3mm External Spiral Lock			10.99	<b>PPE-17945</b>	x

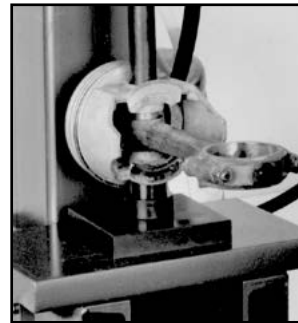

## Universal Piston Pin Press-Out Tool

- Use with a shop press
- Top quality steel tooling
- Standard set handles most applications
- You can modify for individual needs

Description	Jobber	Order No.	Incl.	
<b>Piston Pin Extractor Kit</b>	\$269.99	<b>PPE-1</b>	▼	
<b>Rod Support Kit</b>	79.99	<b>PPE-1GM-KIT</b>	▼	
<b>Piston Support Fixtures</b>				
	.800" hole	22.99	<b>PPE-1A</b>	x
	.865" hole	22.99	<b>PPE-1F</b>	x
	.950" hole	22.99	<b>PPE-1B</b>	x
	1.010" hole	22.99	<b>PPE-1C</b>	x
	1.010" hole	22.99	<b>PPE-1D</b>	x
	1.110" hole	22.99	<b>PPE-1E</b>	x
<b>Fixture Base Block</b>	37.99	<b>PPE-1G</b>	x	
<b>Pin Pressing</b>				
	.760" dia.	19.99	<b>PPE-1H</b>	x
	.812" dia.	19.99	<b>PPE-1J</b>	x
<b>Drifts</b>				
	.875" dia.	19.99	<b>PPE-1K</b>	x
	1.000" dia.	19.99	<b>PPE-1L</b>	x
<b>Tapped Handle</b>	17.99	<b>PPE-1M</b>	x	
<b>Threaded Rod</b>	8.99	<b>PPE-1N</b>	x	
<b>Threaded Adaptor</b>	15.99	<b>PPE-1P</b>	x	
<b>Rod Support</b>	18.79	<b>PPE-1GM</b>	x	

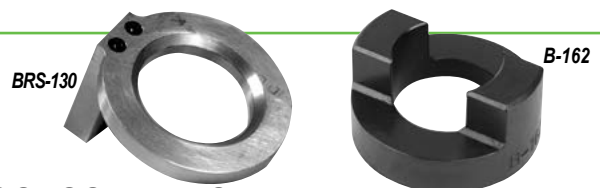

## GOODSON Rod Support for Sunnen® Pin Press Tooling

- Remove late model connecting rods from tapered boss pistons
- Aluminum construction prevents connecting rod damage • Fits Sunnen® tooling

Description	Jobber	Order No.
GOODSON Rod Support	\$62.29	<b>BRS-130</b>
Sunnen® Reducing Ring	79.99	<b>B-162</b>

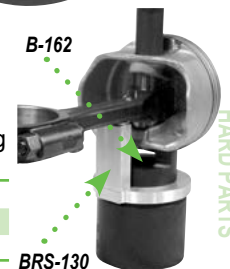

CYLINDER HEAD REBUILDING ASSEMBLY & SAFETY SHORT BLOCK REBUILDING CRANKSHAFT/ FLYWHEEL GRINDING TOOLS & SUPPLIES MISCELLANEOUS BRAKE & TIRE MEASURING TOOLS V-TWIN & METRIC HARD PARTS



"Our easy-to-use, comprehensive catalog features more than 8,000 tool and supplies. Feel free to call if you're not sure what to order or if you have questions. We'll do everything we can to help you get what you need."

- Diane, Purchasing Department - 2 years of service

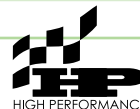

CYLINDER HEAD REBUILDING  
CLEANING, ASSEMBLY & SAFETY  
SHORT BLOCK REBUILDING  
CRANKSHAFT/ FLYWHEEL GRINDING  
MISCELLANEOUS TOOLS & SUPPLIES  
BRAKE & TIRE CHANGING TOOLS  
MEASURING TOOLS  
V-TWIN & METRIC HARD PARTS

## Piston Installing Deadblow Hammer

- 1-piece design
- Specially formulated, urethane compound is cut and split resistant
- Convex-faced
- Non-mushrooming material
- Offset head
- Ideal for fast, mar-free piston installation
- Weighs 1.7 lbs./ .77 kg
- Order No. **PK-200** Jobber \$49.99



## Gas Porting Tools for High Performance

- Virtually eliminate side ring clearance by drilling gas ports in your piston ring lands
- These tiny ports apply compression pressure directly to the back of the ring, pushing it against the cylinder wall with greater force while minimizing compression leakage
- Gas ports work best with piston-compression heights of 1.2" or less on engines running at high rpm (7,000 or higher)
- These simple Tool Kits take all of the guess-work out of gas porting and include everything you'll need to get started
- The complete kit includes: Drill Fixture, Depth Bushing and one Drill Bit

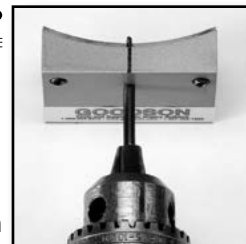

Buy all 3 kits, save 10% off jobber!



**US Patent No. US D617,664 S**

Description	Size	Jobber	Order No.
Gas Porting Tool Kits	.043"	\$99.99	<b>GPT-043</b>
	.062" and 1.5mm	99.99	<b>GPT-062</b>
	.078"	99.99	<b>GPT-078</b>
Replacement Drill Bits (5 pack)	.040" for GPT-043	7.99	<b>GPT-040-DB</b>
	.062" for GPT-062/GPT-078	7.99	<b>GPT-062-DB</b>



## tech tips from the techxperts™

For trouble free installation when installing pistons, use the Band Ring Compressors along with the Dead Blow Piston Installing Hammer above



Kits include Compressing Pliers (GPS-98A)

## Band Ring Compressor Kits

- Install rings safely and easily
- Hardened steel for durability
- Trigger ratchet mechanism for tight compressions

Description	Jobber	Order No.	Incl.
6 Pc. Band Ring Compressor Kit	\$44.99	<b>GPS-98</b>	▼
9 Pc. Band Ring Compressor Kit	67.99	<b>GPS-99</b>	▼
Compressing Pliers	22.99	<b>GPS-98A</b>	x x
Bands Range in. mm			
1.875" - 2.125"	47.63-53.98	\$12.99 <b>GPS-98Q</b>	
2.125" - 2.375"	53.98-60.33	12.99 <b>GPS-98R</b>	x
2.375" - 2.625"	60.33-66.68	12.99 <b>GPS-98S</b>	x
2.625" - 2.875"	66.68-73.03	12.99 <b>GPS-98T</b>	x
2.875" - 3.125"	73.03-79.38	12.99 <b>GPS-98B</b>	x x
3.125" - 3.375"	79.38-85.73	12.99 <b>GPS-98C</b>	x x
3.375" - 3.625"	85.76-92.08	12.99 <b>GPS-98D</b>	x x
3.625" - 3.875"	92.08-98.43	12.99 <b>GPS-98E</b>	x x
3.875" - 4.125"	98.43-104.78	12.99 <b>GPS-98F</b>	x x
4.125" - 4.375"	104.78-111.13	12.99 <b>GPS-98G</b>	x x
4.500" - 4.750"	114.30-120.65	13.99 <b>GPS-98H</b>	
4.750" - 5.000"	120.65-127.00	13.99 <b>GPS-98I</b>	
5.000" - 5.250"	127.00-133.35	13.99 <b>GPS-98J</b>	
5.250" - 5.500"	133.35-139.70	13.99 <b>GPS-98N</b>	
5.500" - 5.750"	139.70-146.05	13.99 <b>GPS-98K</b>	
5.750" - 6.000"	146.05-152.40	13.99 <b>GPS-98M</b>	
6.000" - 6.250"	152.40-158.75	12.99 <b>GPS-98U</b>	
6.250" - 6.500"	158.75-165.10	12.99 <b>GPS-98V</b>	

## Minnesota Fast Freeze

- Instantly chills seats and guides to -50°F / -45.5°C
- Creates interference fit with heated aluminum heads
- Finish seat and guide work faster than ever • Aerosol\*
- Use on tight bushings, pins, shafts, etc.
- Order No. **MFF-8** Jobber \$29.99



Buy 6 or more and save 10% off jobber



\*Hazardous Goods Fees Apply When Shipped Air

## Press Fit Lubricants

- A light coat eases press fit
- Ideal for valve guides, piston pins, cylinder sleeves, etc.
- Eliminates the scoring, gouging and galling of parts during press fitting



Description	Jobber	Order No.
Goodson Aerosol 6 oz. (170 g)	\$11.99	<b>PFL-200*</b>
Sunnen® Aerosol 7 oz. (198 g)	17.99	<b>B-200*</b>
Sunnen® Brush Applicator 200 mL (not shown)	25.99	<b>B-200L</b>

\*Hazardous Goods Fees Apply When Shipped Air

Buy 12 or more PFL-200 and SAVE 10% off jobber



**American Made**

## Powered Ring Filers

- No more tedious filing and checking and filing and checking to get desired end gap; set it once and cut multiple rings
- Easy to read integral dial indicator and positive ring stop make repeatable precision quick and easy
- Fits 2 1/2"-5"/63.5-127mm diameter rings
- Adjustable guide holds rings square to the cutting wheel
- Table pivots past cutting wheel
- No open ways to gather grinding dust that causes premature wear
- Handy knurled in-feed adjustment knob
- High torque motor

Diamond Dresser is securely held in place by the ring clamping pin

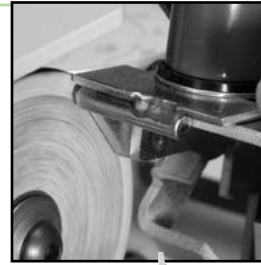

Lighted Rocker Switch

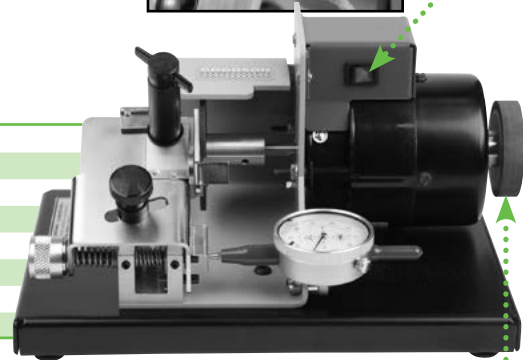

Description	Jobber	Order No.
Powered Ring Filer with Deburring Wheel 110V / 60 cycle	\$899.99	PRF-812DW
Powered Ring Filer with Deburring Wheel 220V / 50 cycle	929.99	PRF-822DW
Replacement Deburring Wheel	39.99	PRF-DW
2 1/2" Replacement Grinding Wheel (60 grit) for pre-2008 models	8.79	PRF-1001
3" Replacement Grinding Wheel (60 grit)	8.79	PRF-1002
Replacement Diamond Dresser	32.99	PRF-812D
Replacement Table Spring	24.99	PRF-SPRING

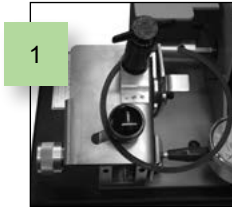

1 Stainless Steel Table

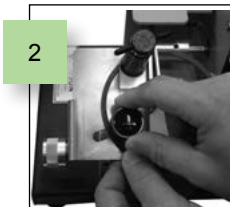

2 Eccentric adjusts quickly and easily

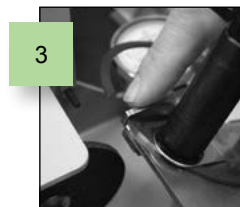

3 Positive ring stop

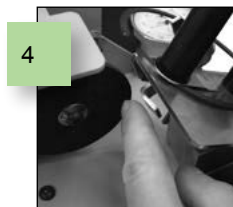

4 Table pivots past grinding wheel

Built-in deburring wheel eliminates the need to hand hone or deburr rings after filing

## Manual Ring Grinder

- Produce end gap rings squarely
- Heavy duty aluminum casting
- Precisely machined for long life
- Silicon-carbide wheel holds shape and produces clean precise cuts
- Includes 1 grinding wheel (replacements available)
- Wheel measures 2 1/2" OD x 7/16" ID x 1/8" thick

Description	Jobber	Order No.
Piston Ring Grinder	\$99.99	PRF-250
Replacement Wheel	15.99	PRF-250W

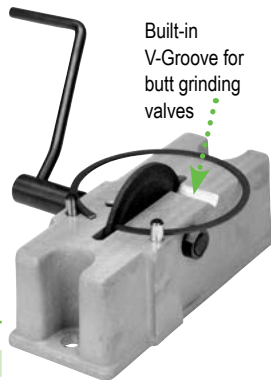

Built-in V-Groove for butt grinding valves

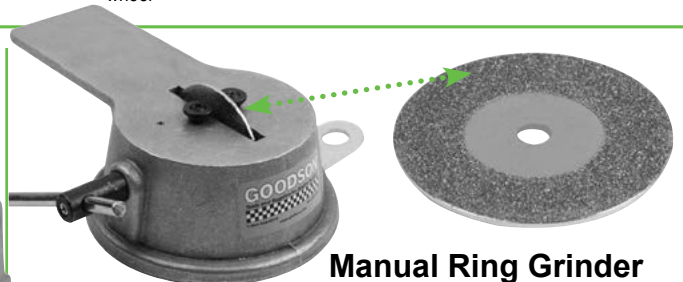

## Manual Ring Grinder

- Universal design lets you grind almost any make, type or size of piston ring
- Includes 1 diamond abrasive wheel

Description	Jobber	Order No.
Universal Piston Ring Filer	\$68.99	PRF-500
Replacement Diamond Abrasive Wheel	44.99	PRF-870-DW

## Fine Abrasive Stick

- Radiused for easier ring deburring after end gapping
- 4" L x 1/2" radius (101.6mm x 12.7mm)
- Works on all types of rings
- Works on ring ID radii
- Order No. **RS-103**  
Jobber \$29.99



## tech tips

from the techxperts™  
Fine Abrasive Sticks work great for deburring the ends of piston rings after filing, or any part that needs deburring. For a finer finish, soak the abrasive stick in Lapping Oil (LP-LO-4).

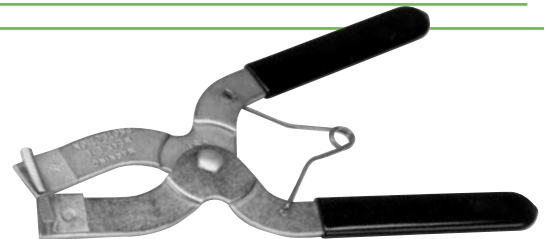

## Piston Ring Expander

- Remove & install most rings
- Tapered jaws
- 3/64" to 1/4" 1.2mm to 6.35mm ring width
- Order No. **PRE-500**  
Jobber \$13.99

CYLINDER HEAD REBUILDING  
CLEANING, ASSEMBLY & SAFETY  
SHORT BLOCK REBUILDING  
FLYWHEEL GRINDING  
CRANKSHAFT/ MISCELLANEOUS TOOLS & SUPPLIES  
BRAKE & TIRE CHANGING TOOLS  
MEASURING TOOLS  
V-TWIN & METRIC HARD PARTS

... another satisfied customer



"All of the business I have done with Goodson has been excellent. My sales rep is very helpful, polite and courteous. My rating of her and your tech staff on a scale of 1 to 10 is a 12! Keep up the good work."

- Richard Stokes, Carquest, Winchester, Virginia, Goodson customer since 1990

**Goodson**  
exclusive

CYLINDER HEAD REBUILDING  
CLEANING, ASSEMBLY & SAFETY  
SHORT BLOCK REBUILDING  
CRANKSHAFT/ FLYWHEEL GRINDING  
MISCELLANEOUS TOOLS & SUPPLIES  
BRAKE & TIRE CHANGING TOOLS  
MEASURING TOOLS  
V-TWIN & METRIC HARD PARTS

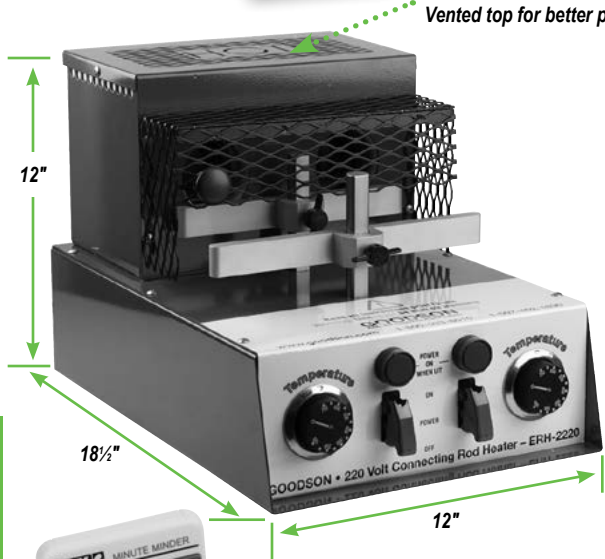

**220V, Single-Phase Electric Rod Heater**

- Double wall insulated heating chambers are covered with a safety screen to keep out foreign objects (like fingers)
- Rod supports adjust for height and distance, allowing you to properly support most automotive connecting rods
- Each element operates on a separate thermostat giving you greater control and the ability to work more efficiently
- High intensity LED lamps indicate that the elements have power and may be hot
- Toggle switches are protected by flip-up shields to prevent accidental activation
- Heating chamber opening measure 2 1/8" to fit standard eyes
- Powder coated, heavy-gauge steel housing for long life
- Non-slip rubber feet provide stability
- Includes a digital timer and 450° temperature crayon

Description	Jobber	Order No.
220V, 50/60 Hz Single Phase Electric Rod Heater	\$1149.99	ERH-2220
Digital Read-Out Timer (battery included)	20.99	ERH-TIMER
Replacement Toggle Switch (ea.)	19.99	ERH-SWITCH
Replacement Toggle Switch Guard (ea.)	47.99	ERH-TSG
Replacement Thermostat (ea.)	99.99	ERH-THERM
Replacement Coil (ea.)	89.99	ERH-COIL
Replacement LED Light Assembly (ea.)	49.99	ERH-LED
Replacement Bezel Knob (ea.)	16.99	ERH-KNOB
Replacement Thumbscrew (ea.)	8.99	ERH-TST
450° Melting Point Temperature Indicator Crayon	17.99	TIC-450
Piston Pin Installation Fixture	69.99	PIF-25

**American Made**



ERH-TIMER

Use with our Piston Pin Installing Fixture (PIF-25) sold separately (see page 89 for a complete description).



WorldwideShipping

**Assemble 8 rods & pistons in as little as 5 minutes**

**Gas-Fired Rod Heater**

- Needs no warm-up time – you can start assembling rods and pistons almost immediately
- Heats piston pin ends so fast that the rest of the rod stays cool
- Minimal cool down time after assembly
- Ceramic lined enclosure contains flame, keeping hands safe
- One knob controls the pilot and gas flow, another sets air flow for ideal combustion
- Burner lights easily with a striker (not included)
- No heat coils to burn out or circuitry to fail
- Includes one 600°F Temperature Crayon (see right)
- Propane model includes gas regulator and hose assembly
- Natural Gas model hooks up to your natural gas service

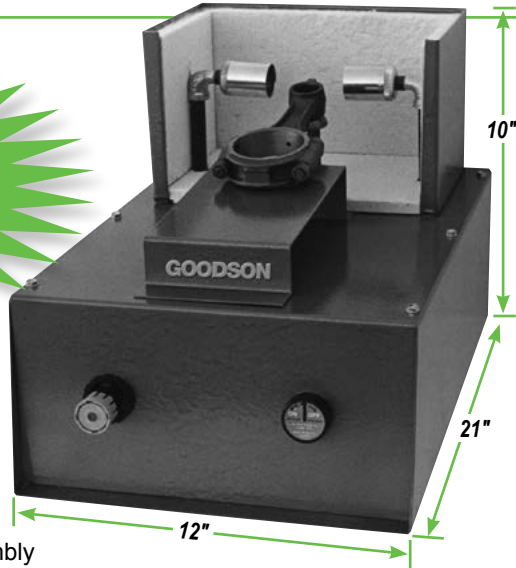

**American Made**

WorldwideShipping



**Buy 3, get 10% off jobber**

**Temperature Indicating Crayons**

- Mark the workpiece before heating
- Melts when temperature is reached
- 3 melting points to choose from

Description	Jobber	Order No.
Rod Heater for Propane	\$879.99	RH-50
Rod Heater for Natural Gas	879.99	RH-50N
600°F Temperature Crayon	17.99	TIC-600

Melting Point	Jobber	Order No.
450°F/232.22°C	\$17.99	TIC-450
500°F/260.00°C	17.99	TIC-500
600°F/315.56°C	17.99	TIC-600

**Works great with Rod Heaters on previous page!**

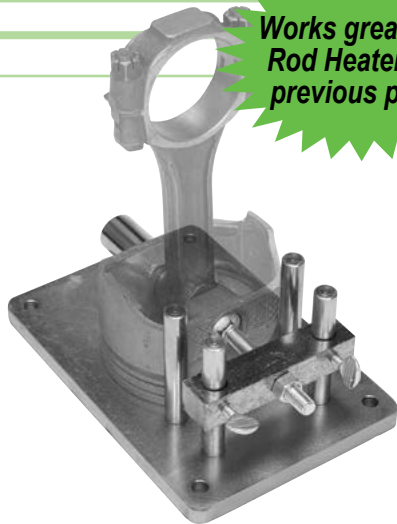

## Piston Pin Installing Fixture

- Base is pre-drilled to mount to a workbench
- Adjustable stops prevent over-centering rods
- Adjust the stop once and you're ready to assemble a full set of rods
- Order No. **PIF-25**  
Jobber \$69.99



## Rod Bolt Boots

- Save crank journals from rod bolt damage
- Don't risk your reputation for quality
- Plastic boots protect crank journals & rod bolts during piston installation
- Reusable
- Set of 16
- Order No. **RBP-16**  
Jobber \$7.99

## Rod Clamping Vise

- Align rods and caps perfectly
- Won't damage connecting rods like an ordinary vise
- Clamp rods firmly to align parting faces while torquing rod bolts
- Clamp in a vise or bolt to a workbench
- Order No. **RCV-20**  
Jobber \$137.99



## Heavy-Duty Rod Bolt Installing Block

- Mount universal block in a vise to support rod while installing bolts
- Hardened aluminum won't slip
- If the top wears, you can restore it with a file or belt grinder
- Ream holes larger to accommodate oversize bolts
- Order No. **RB-50**  
Jobber \$43.79



Connecting Rod not included

# The best engine pre-lube tank in the industry!



## 12 Quart Engine Pre-Lube Tank

- 12 quart capacity is 2½ times larger than most pre-lube tanks
- Corrosion-resistant aluminum tank eliminates contamination from rust
- Pressure gauge (A) allows positive control of tank pressure
- Pop-off pressure release valve (B) eliminates the risk of over-pressurizing the tank
- Brass and Dirlin Teflon® ball valve (C)
- Large 1½" diameter fill hole lets you pour right from the oil bottle - no funnel required
- 8' long, ¼" fill hose gives you enough length to work easily
- Includes 2 standard fittings AND 1 fitting for the LS engine

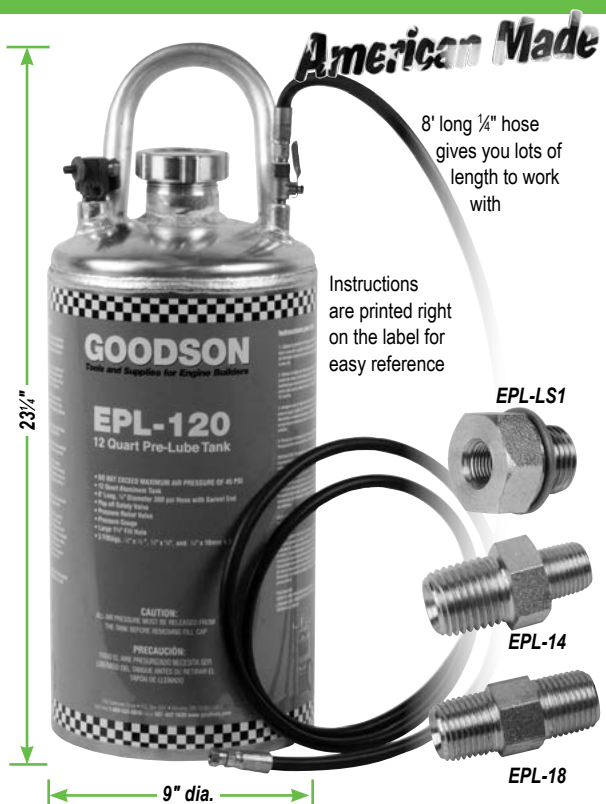

**American Made**

8' long ¼" hose gives you lots of length to work with

Instructions are printed right on the label for easy reference

EPL-LS1

EPL-14

EPL-18

Description	Jobber	Order No.
12 Quart Pre-Lube Tank	279.99	EPL-120
Replacement 8' Hose	39.99	EPL-HOSE
LS1 Fitting	29.99	EPL-LS1
¼" Replacement Fitting	3.99	EPL-14
½" Replacement Fitting	3.99	EPL-18
Replacement Gauge	12.99	EPL-CG
Replacement Cap Gasket	12.99	EPL-G

CYLINDER HEAD REBUILDING ASSEMBLY & SAFETY CLEANING SHORT BLOCK REBUILDING CRANKSHAFT/ FLYWHEEL GRINDING TOOLS & SUPPLIES MISCELLANEOUS BRAKE & TIRE CHANGING TOOLS MEASURING TOOLS V-TWIN & METRIC



"Technology has merely provided us with more efficient ways to give you, our customers, the quality of service you deserve! Our goal is to make ordering shop supplies faster & easier for you, whether you order by phone or through our website."

- Cheryl, Goodson Computer Systems Analyst - 21 years of service

CLEANING, CYLINDER HEAD REBUILDING  
ASSEMBLY & SAFETY

## Oil Gallery Plug Installer / Staker

- Set depth and lock plug in a single step
- Arbor nose aligns cup plug, then follows with two 180° staker lugs to set depth and lock oil gallery plug securely in place
- Order No. **ST-SB**  
Jobber \$39.99

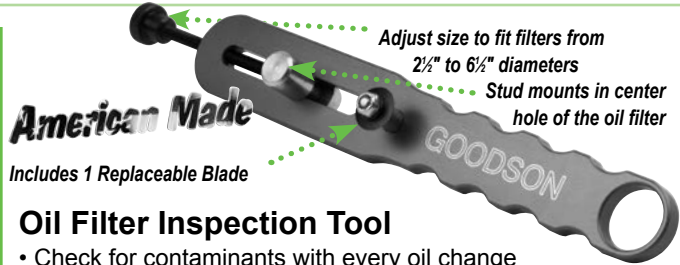

## Oil Filter Inspection Tool

- Check for contaminants with every oil change
- Cut open the filter canister for inspection
- Fits 2 1/2" to 6 1/2" diameter filters
- Includes a single blade

Description	Jobber	Order No.
Oil Filter Inspection Tool	\$54.99	<b>FIT-1-G</b>
Replacement Cutter Blade	11.99	<b>FIT-W</b>

SHORT BLOCK REBUILDING

## Oil Gallery Plugs

- Replace lost or damaged originals
- 1/4" / 6.35mm plugs
- For use at the rear of Small Block Chevy oil galleries or other engines with similar size plugs
- 25 per box
- Order No. **OP-250**  
Jobber \$7.99

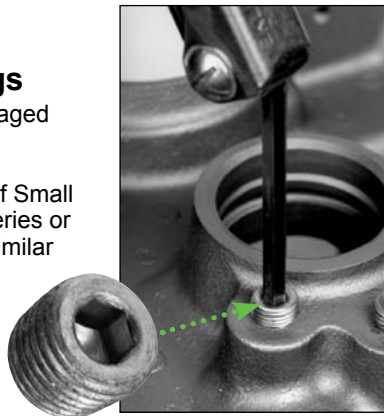

## Oil Pump Pickup Tube Driver

- For all GM pumps
- Replace pickup tubes easily with a light mallet
- Driver grips the pickup tube flare
- Gives control for fast alignment and installation

Application	Tube OD	Jobber	Order No.
Small Block	5/8" / 15.9mm	\$29.99	<b>TI-25</b>
Big Block	3/4" / 19.1mm	29.99	<b>TI-30</b>

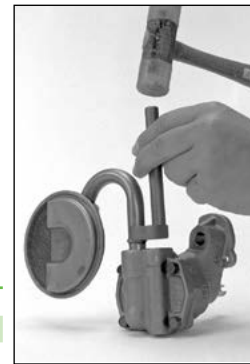

CRANKSHAFT/ FLYWHEEL GRINDING

## Oil Gallery Brushes

Steel Wire	Jobber	Order No.	Incl.
<b>3-pc. Kit</b>			
Size	Length		
1/4" x 3"	24"	\$16.99	<b>OGB-SK</b> ▼
3/8" x 3"	24"	7.49	<b>OGB-1</b> x
5/8" x 3"	24"	8.49	<b>OGB-2</b> x
5/8" x 3"	24"	9.49	<b>OGB-3</b> x
<b>Nylon Bristle</b>			
<b>5-pc. Kit</b>			
Size	Length		
3/8" x 3"	34"	\$27.99	<b>OGB-KIT</b> ▼
1/2" x 2 1/2"	34"	6.49	<b>OGB-38</b> x
1/2" x 2 1/2"	34"	6.79	<b>OGB-42</b> x
5/8" x 3"	34"	6.79	<b>OGB-5</b> x
3/4" x 3"	34"	7.49	<b>OGB-7</b> x
3/4" x 3"	40"	8.99	<b>OGB-8</b> x

Buy 5 or more brushes (any combination), take 10% off jobber! Buy 15 or more brushes (any combination), take 15% off jobber! More brushes on page 62.

MISCELLANEOUS TOOLS & SUPPLIES



## Oil Gallery Plug Removers

- Power plugs out with an impact wrench
- Threaded plug inside prevents bit from backing into the holder
- 1/2" / 12.7mm drive – fits impact wrenches
- Hardened tool-steel holder with lifetime breakage guarantee
- Tool-steel bit can be reground or replaced
- Set screw holds bit firmly in place



Description	Size	Jobber	Order No.	Incl.
<b>Plug Remover Kit</b>	in		\$144.99	<b>PPS-KIT</b> ▼
<b>Replacement Tool</b>	3/16"	4.76	39.99	<b>PPS-187</b> x
	1/4"	6.35	39.99	<b>PPS-250</b> x
	5/32"	7.14	41.99	<b>PPS-281*</b> x
	5/16"	7.94	39.99	<b>PPS-312</b> x
	3/8"	9.53	39.99	<b>PPS-375</b> x
<b>Replacement Bits</b>	3/16"	4.76	\$11.49	<b>PPS-187B</b>
	1/4"	6.35	11.49	<b>PPS-250B</b>
	5/16"	7.94	11.49	<b>PPS-312B</b>
	3/8"	9.53	11.49	<b>PPS-375B</b>

NOTE: \*No bit is needed for PPS-281 (square socket).

CHANGING TOOLS

## Oil Gallery Wax

- Preheat the part to be removed, apply wax to its base, allow to cool and remove the part
- Choose between wax sticks and blocks of beeswax



Description	Jobber	Order No.
Oil Gallery Wax - 6" sticks (10 pk.)	\$17.99	<b>OGW-1</b>
Beeswax Stick - 1" x 3/4" x 3" / 25.4 x 19.1 x 76.2mm	4.99	<b>BWS-1</b>

MEASURING TOOLS

V-TWIN & METRIC HARD PARTS



## Lifter Bore Burnishing Tool

- Eliminates burrs caused by shot blasting
- Drive the burnishing tool into the bore with a soft hammer, then slide-hammer it back out
- 60Rc burnishing balls deburr faster
- Won't oversize the bore

Description	Jobber	Order No.
<b>Full Kit:</b>	\$149.99	<b>LBB-1500</b> ▼
Slide Shaft	12.49	<b>GAO-1</b> x
Slide Hammer	21.99	<b>GAO-2</b> x
Jam Nut	7.99	<b>LBB-NUT</b> x
<b>Lifter Bore Burnishing Balls</b>		
<b>Complete Set</b>	\$119.99	<b>LBB-3SET</b> ▼
GM .845" dia.	39.99	<b>LBB-GM1</b> x x
Ford .876" dia.	39.99	<b>LBB-FO1</b> x x
Chrysler .906" dia.	39.99	<b>LBB-CR1</b> x x

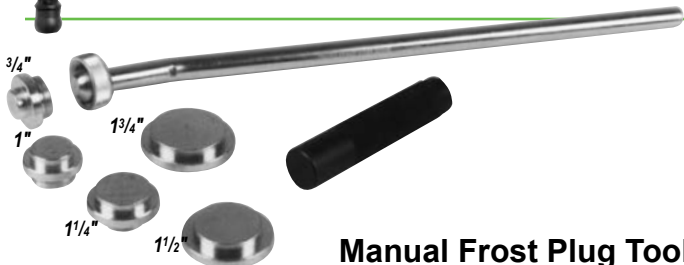

## Manual Frost Plug Tool

- Minimizes the chance of frost plug distortion and leakage
- Two handle lengths – use the short handle for rebuild jobs, and the long handle for engines still in the vehicle
- Kit includes five sizes of installing plugs, ring nut and two steel handles
- Replacement parts available – call for details
- Order No. **FP-20** Jobber \$69.99



## Rod Honing Oil

- Includes additives for high pressure cutting
- Keeps stones clean and free-cutting during rod reconditioning, pin fitting and other honing applications
- Will mix with other honing oils (including Sunnen®)

Size	Jobber	Order No.
1 Gal./3.78L	\$ 34.99	<b>RHO-10</b>
5 Gal./18.9L	174.99	<b>RHO-50</b>

## Clear Honing Oil

- Helps keep stones clean and free-cutting
- Ideal for portable hones and all makes of automotive honing machines
- Mixes easily with other brands, including Sunnen®
- Not water soluble

Size	Jobber	Order No.
1 Gal./3.78L	\$ 26.99	<b>HO-10</b>
5 Gal./18.9L	114.99	<b>HO-50</b>

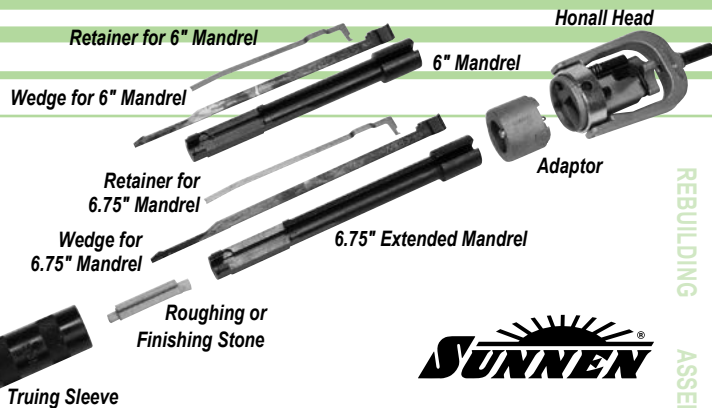

## Sunnen® Lifter Bore Hones

- Restore bore size and finish after shot blasting
- Install oversize lifters for high-performance
- Stones work in cast iron bores or ones sleeved with brass or steel
- Wide stones contact a large area giving better stability for hand honing
- Cross oil ports without catching
- Wedge-type adjustment is a simple, positive way to expand or contract the stone to the precise size
- Use a 3/8"/9.5mm or 1/2"/12.7mm hand-held electric or air drill at approx. 200 RPM
- Use with honing oil
- **All parts MUST be ordered separately to make a complete unit**

**tech tips**  
from the techxperts™

**NOTE:** Wedges may come with a tab that must be removed **BEFORE** using them with the P-180 Head

Description	Jobber	Order No
Honall Head	\$324.44	<b>P-180</b>
Adaptor	63.57	<b>PAK20-A</b>
Roughing Stone (280 Grit) 12/box	97.32	<b>Y20-J67</b>
Finishing Stone (400 Grit) 12/box	97.32	<b>Y20-J87</b>
<b>Standard Lifter Bore Tooling (6" Reach)</b>		
Mandrel .838" - .869" Range	\$318.01	<b>AA20838BH6LH</b>
.869" - .900" Range	318.01	<b>AA20869BH6LH</b>
Wedge	62.61	<b>Y20-W-6LH</b>
Retainer	39.99	<b>LN-3688A-6LH</b>
Truing Sleeve .838" - .869" Range	16.78	<b>S-838</b>
.869" - .900" Range	16.78	<b>S-869</b>
<b>Extended Reach Lifter Bore Tooling (6 1/2" Reach)</b>		
Mandrel .838" - .869" Range	\$318.01	<b>AA20838675LH</b>
.869" - .900" Range	318.01	<b>AA20869675LH</b>
Wedge	62.61	<b>Y20-W-675LH</b>
Retainer	39.99	<b>LN-3688A675LH</b>
Truing Sleeve .838" - .869" Range	16.78	<b>S-838</b>
.869" - .900" Range	16.78	<b>S-869</b>

## Severe Duty Valve Refacer Oil

- Mineral Based
- Formulated for titanium, Inconel®, stainless steel and stellite
- Includes additives to improve cutting performance under high pressure
- Ideal for lifter bore honing

Size	Jobber	Order No.
1 Gal./3.78L	\$ 34.99	<b>VGO-SD10</b>
5 Gal./18.9	174.99	<b>VGO-SD50</b>



CYLINDER HEAD REBUILDING ASSEMBLY & SAFETY CLEANING, SHORT BLOCK REBUILDING CRANKSHAFT/ FLYWHEEL GRINDING TOOLS & SUPPLIES MISCELLANEOUS BRAKE & TIRE MEASURING TOOLS V-TWIN & METRIC HARD PARTS

CYLINDER HEAD REBUILDING  
CLEANING, ASSEMBLY & SAFETY  
REBUILDING  
SHORT BLOCK REBUILDING  
CRANKSHAFT/ FLYWHEEL GRINDING  
MISCELLANEOUS TOOLS & SUPPLIES  
BRAKE & TIRE CHANGING TOOLS  
MEASURING TOOLS  
HARD PARTS



Brushed Aluminum Storage Rack Included with kit purchase

### Universal Cam Bearing Tool

- Remove and install hundreds of sizes of cam bearings with just four mandrels!
- Expanding Mandrels cover a 1.370"-2.250" range
- Adjusts to undersize bearings so you can remove and install them from virtually any block
- *Interchangeable with Dura-Bond*

Description	Jobber	Order No.	Incl.
<b>Universal Cam Bearing Tool</b>	\$469.99	CBT-300	▼
<b>Replacement Segments with Sleeves</b>			
Max Dia. 1.370"	\$ 55.79	CBT-5M	x
1.682"	55.79	CBT-6M	x
1.875"	60.79	CBT-7M	x
2.250"	66.99	CBT-8M	x
<b>Replacement Backing Plates</b>			
Max Dia. 1.370"	\$ 14.79	CBT-5W	x
1.682"	16.79	CBT-6W	x
1.875"	17.79	CBT-7W	x
2.250"	18.99	CBT-8W	x
<b>Replacement Neoprene Sleeves</b>			
Max Dia. 1.370"	\$ 7.49	CBT-5NS	x
1.682"	8.99	CBT-6NS	x
1.875"	8.99	CBT-7NS	x
2.250"	11.29	CBT-8NS	x
<b>Drivers</b>			
Length 5"	\$ 52.49	CBT-1B	x
24"	104.99	CBT-2B	x
36"	136.49	CBT-3B	x
48"	146.99	CBT-4B	x
<b>Miscellaneous Replacement Parts</b>			
1 1/16" Expander with stud	\$ 56.79	CBT-3E	x
1 5/8" Expander with stud	53.79	CBT-4E	x
1/2"x13 Stud	11.79	CBT-1S	x
Guide Cone	31.49	CBT-1C	x
Threaded Impact Cap (New Style)	45.49	CBT-300-CAP	x
<b>INTERCHANGEABLE WITH DURA-BOND</b>			

### Chevy Starter Drill Jig

- Drill & tap guide for perfect alignment
- For blocks missing inner mounting bolt hole necessary for use with mini starters
- Also use as a drilling and tapping jig for removing broken starter bolts
- Allows easy repair of the fastener holes
- Use with standard drills and taps (not included)
- 3 heat-treated tool/steel machining plates
- Order No. **SDJ-1** Jobber \$114.99



### Degree Wheel

- Check cam timing, duration and overlap
- Degree wheel measures 11" / 279.4mm dia. with 1 7/8" / 47.6mm hole • Small ID Adaptor Kit mounts it to cranks using 7/16" to 3/4" / 11.1 to 19.1mm fasteners or use the turning tool for that engine to mount the wheel
- Use with 1/2" / 12.7mm drive ratchet

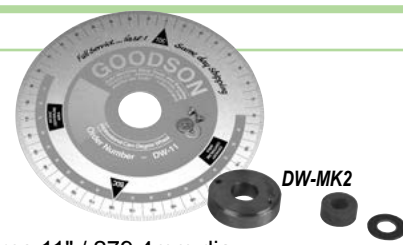

Wheel / Adaptors	Jobber	Order No.	Incl.
Automotive Degreasing Kit	\$59.99	DW-KIT-2	▼
Degree Wheel	29.99	DW-11	x
Small ID Adaptor Kit	15.99	DW-MK2	x

### Bearing Scraper

- Eliminate bearing high spots after installation to assure correct oil clearance
- Solid, wire wound, wood handle for strength and resistance to splitting
- 4" / 101.6mm blade with 3 cutting edges
- Order No. **BS-30** Jobber \$25.49



### Cam Bolt Locking Plate

- Keep timing bolts from backing out
- Use to secure timing sprockets
- Ideal for small block, high-performance Chevys
- Order No. **CBL-9** Jobber \$3.99

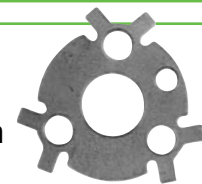

### 6 Piece Small Block Chevy Deck Plug Kit

- 3/4" NPT cast iron plugs
- Help stabilize the critical deck area on Small Block Chevys
- Eliminates deck walk for better stability, ensuring a better ring seal
- Order No. **DPK-SB** Jobber \$24.29



### Lifting Sling

- Lift up to 1800 lbs./816.5 kg safely and easily
- 1" x 36"/25.4x914.4mm looped sling
- Secure the sling to the workpiece and move it with your overhead hoist
- Durable, nylon webbing
- Not for use with caustics or temperatures exceeding 190°F / 87.8°C
- Order No. **LS-3** Jobber \$10.99



## Whether you're regrinding cores for stock applications or custom grinding for diesel and high performance, you can count on Goodson Cam Grinding Wheels to deliver an excellent finish

Goodson abrasives are second to none. We work with our manufacturer to get you the most ideal grain that's bonded to be free-cutting, yet still shed before loading up. Our Premium wheels are ideal for steel high performance camshafts of 55 to 65 Rc and for Stellite overlays. Goodson makes all Camshaft Grinding Wheels to your specifications in-house for fast turn-around and delivery. Choose from the sizes below or custom order your cam wheel today!



### Cam Grinding Wheels - WAA54-L5V1

Diameter	Width	Arbor	Jobber	Order No.
18"	3/4"	19mm	6" 152mm	\$194.99 E341420
457mm	7/8"	22mm	6" 152mm	194.99 E335351
	1"	25mm	6" 152mm	194.99 E335352
	1 1/8"	29mm	6" 152mm	214.99 E335353
	1 1/4"	32mm	6" 152mm	214.99 E335354

### Cam Grinding Wheels - 43A602-K8-V1

Diameter	Width	Arbor	Jobber	Order No.
18"	3/4"	19mm	6" 152mm	\$179.99 E342030
457mm	7/8"	22mm	6" 152mm	189.99 E339945
	1"	25mm	6" 152mm	194.99 E342031
	1 1/4"	32mm	6" 152mm	217.99 E348558

### Cam Grinding Wheels - 70BL801

Diameter	Width	Arbor	Jobber	Order No.
18"	3/4"	19mm	6" 152mm	\$249.99 E416880
457mm	7/8"	22mm	6" 152mm	249.99 E427392

Due to the manufacturing process, actual colors may vary

### Cam Grinding Wheels - WAA100

18"	3/4"	19mm	6" 152mm	\$194.99 E379225
457mm	7/8"	22mm	6" 152mm	209.99 E397667
	1"	25mm	6" 152mm	209.99 E416878
	1 1/4"	32mm	6" 152mm	209.99 E348558

### Standard Goodson Cam Grinding Wheels - 100 grit

Diameter	Width	Arbor	Jobber	Order No.
18"	3/4"	19mm	6" 152mm	\$153.99 GCC 18 x 0.750 x 6
457mm	7/8"	22mm	6" 152mm	153.99 GCC 18 x 0.875 x 6
	1"	25mm	6" 152mm	183.99 GCC 18 x 1.000 x 6
	1 1/8"	29mm	6" 152mm	299.99 GCC 18 x 1.125 x 6
	1 1/4"	32mm	6" 152mm	299.99 GCC 18 x 1.250 x 6

All Radiac Camshaft Grinding Wheels are the same grit, grain and bond that you have ordered in the past.

## Torque-Angle Indicator

- When torque is given as degrees of turn past a certain ft./lb., use this gauge to show degrees
- 1/2" square drive
- Hold metal base with one hand
- Plastic dial turns as you tighten
- Fits between a socket-driven extension and the socket
- Order No. **TQR-4554**
- Jobber \$19.99



## Bore Washing Brushes

- Clean tunnel housing bores and full-annular grooved area
- Heavy, hand-driven shank

Dia.	Length	Jobber	Order No.
2"	36"	\$18.99	CBB-200
2 1/4"	36"	19.99	CBB-225
2 1/2"	36"	20.99	CBB-250
2 3/4"	18 1/2"	23.29	CWB-27W
3 1/2"	18 1/2"	23.29	CWB-35
4"	18 1/2"	23.29	CWB-40
4 1/2"	18 1/2"	24.29	CWB-45
5"	18 1/2"	25.29	CWB-50



 Buy 5 or more brushes (any combination), take 10% off jobber! Buy 15 or more brushes (any combination), take 15% off jobber! More brushes on page 62.

## Diamond Impregnated Cam Dresser

- 7/16" OD
- 1 9/16" OAL
- .094" Face Width
- .370 Face Length
- Fits most cam grinders
- Order No. **2V9507**
- Jobber \$99.99



## Cam Bearing Flex-Hones®

- Silicon-Carbide globules laminated to high density nylon
- Includes 18" drive rod
- 180 grit

Inch	mm	Jobber	Order No.
1 1/4"	45	\$44.29	CBF-175
2"	51	44.79	CBF-200
2 1/4"	57	46.79	CBF-225
2 1/2"	64	48.79	CBF-250
2 3/4"	70	60.99	CBF-275

Buy 3 or more Flex-Hones® (any combination), SAVE 10% off jobber More Flex-Hones® on page 72 

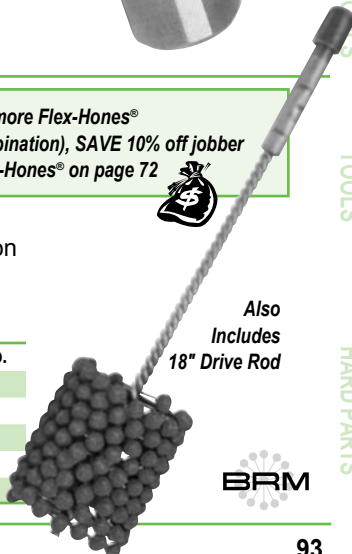

Also Includes 18" Drive Rod



CYLINDER HEAD REBUILDING  
CLEANING, ASSEMBLY & SAFETY  
SHORT BLOCK REBUILDING  
CRANKSHAFT/FLYWHEEL GRINDING  
MISCELLANEOUS TOOLS & SUPPLIES  
BRAKE & TIRE CHANGING TOOLS  
MEASURING TOOLS  
V-TWIN & METRIC HARD PARTS

full service  
**...fast**



"We're continually expanding our production department to provide more flexibility in grinding wheel shapes, sizes and profiles. Give us a call when you need something special."

- Orlo, Goodson Production - 31 years of service

## Goodson crankwheels are made-to-order in-house

Other sources stock finished wheels, which makes it virtually impossible to stock a full size range. If they don't have what you need, they may charge more and delay your order for weeks. That's why Goodson makes every wheel to order. We always have the right wheel because we take a Type 1 straight wheel, size it, shape it, speed test it and ship it.



For future reference write down your

Crank Wheel Number (s)

### Select the shape



Hub

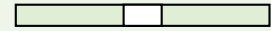

Straight

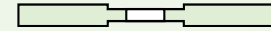

Recessed 2 Sides



Tapered

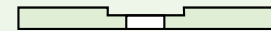

Recessed 1 Side

## Select your wheel grade:

### GCH Superior Grade - 54 grit

Better form holding ability, cuts cooler and needs less dressing. Use on crank journals with Rockwell hardness of 35 Rc or less. Use on crankshafts of cast or forged steel, Nodular iron. Ideal for large radii, thrust and plunge grinding. Great for high-performance.

### GCD Premium Grade - 60 grit

For harder materials. Good form holding ability; cuts cooler and needs less dressing. Grains yield faster, cooler grinding. Use on journals with Rockwell hardness of 35 Rc or more. Ideal for diesel, high-performance, industrial and billet steel.

## Increase coolant flow with Crankwheel Slotting

Slotting facilitates the flow of coolant to the thrust and radius areas of the crankshaft. Don't waste time waiting on other suppliers who outsource their crankwheels for slotting - Goodson has a shop full of equipment, so we slot wheels in house!

## How to order:

If you have any questions, please call 1-800-533-8010

Grade	Diameter	Face Width	Arbor Size	Machine	Shape
GCH - Superior	Diameters are available from 18" to 36" in most grades.	Most sizes from 3/4" to 2 5/8" (custom widths are no extra charge).	Arbor size of your grinder. Any arbor hole from 3" to 12".	Identify the make and model of your grinder.	We send the standard shape for your grinder unless you specify otherwise.
GCD - Premium					

Enter your information below, then call Goodson at 1-800-533-8010 to order

Grade x Diameter x Face Width x Arbor Size x Machine x Shape

Please note, all wheels are delivered .015" oversize to allow for side dressing when mounting

CRANKSHAFT/  
FLYWHEEL GRIND

MISCELLANEOUS  
TOOLS & SUPPLIES

BRAKE & TIRE  
CHANGING TOOLS

MEASURING  
TOOLS

V-TWIN & METRIC  
HARD PARTS

# Crankshaft Grinding Wheels

Dia.	GCH (54 grit)		GCD (60 grit)	
	Jobber	Width	Jobber	Width
Fits Storm Vulcan 14, 15				
18"	\$204.99	3/4"-1"	—	—
3" Arbor	249.99	1 1/4"-1 1/4"	—	—
	369.99	1 17/64"-1 1/2"	—	—
	379.99	1 33/64"-1 3/4"	—	—
	389.99	1 49/64"-2"	—	—
Fits Storm Vulcan 15, 15 Special, 1550, 1648				
20"	\$204.99	3/4"-1"	—	—
3" Arbor	249.99	1 1/4"-1 1/4"	—	—
	369.99	1 17/64"-1 1/2"	—	—
	379.99	1 33/64"-1 3/4"	—	—
	389.99	1 49/64"-2"	—	—
Fits Kwik-Way / Lemppo 519 & Storm Vulcan 15A (early)				
22"	\$359.99	3/4"-1"	—	—
5" Arbor	369.99	1 1/4"-1 1/4"	—	—
	379.99	1 17/64"-1 1/2"	—	—
	389.99	1 33/64"-1 3/4"	—	—
	399.99	1 49/64"-2"	—	—
Fits Peterson Berco 180				
22"	\$359.99	3/4"-1"	\$449.99	3/4"-1"
8" Arbor	369.99	1 1/4"-1 1/4"	529.99	1 1/4"-1 1/4"
	379.99	1 17/64"-1 1/2"	649.99	1 17/64"-1 1/2"
	389.99	1 33/64"-1 3/4"	679.99	1 33/64"-1 3/4"
	399.99	1 49/64"-2"	689.99	1 49/64"-2"
Fits Storm Vulcan 15A (late), 15A Special; RMC/Robbi REX-1200				
24"	\$449.99	3/4"-1"	\$449.99	3/4"-1"
5" Arbor	499.99	1 1/4"-1 1/4"	529.99	1 1/4"-1 1/4"
	549.99	1 17/64"-1 1/2"	649.99	1 17/64"-1 1/2"
	589.99	1 33/64"-1 3/4"	679.99	1 33/64"-1 3/4"
	649.99	1 49/64"-2"	689.99	1 49/64"-2"
Fits Kwik-Way / Lemppo KGA and NKG Series				
24"	\$449.99	3/4"-1"	\$449.99	3/4"-1"
5 1/2" Arbor	549.99	1 1/4"-1 1/4"	529.99	1 1/4"-1 1/4"
	599.99	1 17/64"-1 1/2"	649.99	1 17/64"-1 1/2"
	649.99	1 33/64"-1 3/4"	679.99	1 33/64"-1 3/4"
	699.99	1 49/64"-2"	689.99	1 49/64"-2"
Van Norman 438, 448, 460, 465;				
Winona Van Norman/Zanrosso CG-210 (early); Storm Vulcan Sledum 200				
24"	\$509.99	3/4"-1"	\$449.99	3/4"-1"
8" Arbor	579.99	1 1/4"-1 1/4"	529.99	1 1/4"-1 1/4"
	639.99	1 17/64"-1 1/2"	649.99	1 17/64"-1 1/2"
	679.99	1 33/64"-1 3/4"	679.99	1 33/64"-1 3/4"
	699.99	1 49/64"-2"	689.99	1 49/64"-2"
Storm Vulcan 15C				
25"	\$509.99	3/4"-1"	\$529.99	3/4"-1 1/4"
5" Arbor	579.99	1 1/4"-1 1/4"	599.99	1 17/64"-1 1/2"
	639.99	1 17/64"-1 1/2"	649.99	1 33/64"-1 3/4"
	679.99	1 33/64"-1 3/4"	689.99	1 49/64"-2"
	699.99	1 49/64"-2"	—	—
AMC K1100; Peterson Berco 180, 225; Sledum 200, 230; Van Norman 438, 448, 460, 465, 475, 476; Winona Van Norman CG-210 (late), CG-840				
26"	\$499.99	3/4"-1"	\$519.99	3/4"-1"
8" Arbor	579.99	1 1/4"-1 1/4"	549.99	1 1/4"-1 1/4"
	689.99	1 17/64"-1 1/2"	579.99	1 17/64"-1 1/2"
	719.99	1 33/64"-1 3/4"	739.99	1 33/64"-1 3/4"
	749.99	1 49/64"-2"	759.99	1 49/64"-2"
799.99	2 1/4"-2 1/4"	789.99	2 1/4"-2 1/4"	
Schou 1500/270, 1600, 260				
27 1/2"	\$499.99	3/4"-1"	\$509.99	3/4"-1 1/4"
8 55/64" Arbor	559.99	1 1/4"-1 1/4"	579.99	1 17/64"-1 1/2"
	689.99	1 33/64"-1 3/4"	719.99	1 33/64"-1 3/4"
	719.99	1 49/64"-2"	729.99	1 49/64"-2"
749.99	2 1/4"-2 1/4"	749.99	2 1/4"-2 1/4"	

Dia.	GCH (54 grit)		GCD (60 grit)	
	Jobber	Width	Jobber	Width
Peterson Berco 260; SV Sledum 230, 270/280; Zanrosso Mito 250;				
Van Norman 400, 438, 439, 475, 476, 666; RMC/Robbi REX-1500				
28"	\$549.99	3/4"-1"	\$529.99	3/4"-1"
8" Arbor	679.99	1 1/4"-1 1/2"	579.99	1 1/4"-1 1/2"
	699.99	1 33/64"-1 3/4"	699.99	1 33/64"-1 3/4"
	719.99	1 49/64"-2 1/4"	729.99	1 49/64"-2 1/4"
	—	—	799.99	2 3/8"-2 3/8"
Seest MC62				
30"	\$679.99	3/4"-1"	—	—
6" Arbor	829.99	1 1/4"-1 1/2"	—	—
	839.99	1 33/64"-1 3/4"	—	—
	849.99	1 49/64"-2"	—	—
Zanrosso Mito 280; Storm Vulcan Sledum 270/280;				
RMC / Robbi REX-1800, REX 2200L				
30"	\$699.99	3/4"-1"	\$ 789.99	3/4"-1"
8" Arbor	799.99	1 1/4"-1 1/2"	799.99	1 1/4"-1 1/4"
	819.99	1 33/64"-1 3/4"	809.99	1 17/64"-1 1/2"
	829.99	1 49/64"-2"	819.99	1 33/64"-1 3/4"
	—	—	999.99	1 49/64"-2"
—	—	1079.99	2 1/4"-2 1/4"	
—	—	1099.99	2 3/8"-2 3/8"	
AMC 1400, K1500, K1800; Van Norman 467, 477; Zanrosso				
32"	\$789.99	3/4"-1"	\$ 789.99	3/4"-1 1/4"
8" Arbor	819.99	1 1/4"-1 1/2"	799.99	1 17/64"-1 1/2"
	899.99	1 33/64"-1 3/4"	809.99	1 33/64"-1 3/4"
	899.99	1 49/64"-2"	999.99	1 49/64"-2"
	—	—	1079.99	2 1/4"-2 1/4"
—	—	1099.99	2 3/8"-2 3/8"	
Peterson Berco 280, 300; RMC Robbi REX-1800RM; REX-2200,				
REX-2200RM, REX-2700RM, REX-3100RM				
32"	\$769.99	3/4"-1"	\$ 789.99	3/4"-1"
12" Arbor	829.99	1 1/4"-1 1/2"	859.99	1 17/64"-1 1/2"
	899.99	1 33/64"-1 3/4"	899.99	1 33/64"-1 3/4"
	899.99	1 49/64"-2"	999.99	1 49/64"-2"
—	—	1079.99	2 1/4"-2 1/4"	
—	—	1099.99	2 3/8"-2 3/8"	
Peterson Berco 300, 350; Storm Vulcan Sledum 250; RMC /				
Robbi REX-2200M, 2700M, 3100M; Winona Van Norman 111				
36"	—	—	\$ 869.99	3/4"-1 1/2"
12" Arbor	—	—	1069.99	1 33/64"-2"
	—	—	1179.99	2 1/4"-2 1/4"
	—	—	1284.99	2 3/8"-2 3/8"

**tech tips**  
from the technicians

**NOTE: All wheels are delivered .015" oversized to allow for side dressing when mounting the wheel**



**special order**  
Need larger wheels?  
Ask about a Special Order!

## Cam & Crank Grinding Coolant

• Semi synthetic • Non-nitrite • High-lubricity • Dilute 20:1

Size	Jobber	Order No.
1 Gal. / 3.78L	\$ 33.99	CGC-10
5 Gals. / 18.93L	149.99	CGC-50

CYLINDER HEAD REBUILDING ASSEMBLY & SAFETY CLEANING, SAFETY REBUILDING SHORT BLOCK REBUILDING CRANKSHAFT/FLYWHEEL GRINDING MISCELLANEOUS TOOLS & SUPPLIES BRAKE & TIRE CHANGING TOOLS MEASURING TOOLS V-TWIN & METRIC HARD PARTS

... another satisfied customer

"After being in business almost 30 years now, performing Harley-Davidson cylinder head work for most of that, and running the gamut in the V-Twin industry with various valves, guides, and springs, we have come to realize through flow testing, dyno testing, and along with client feedback, that there is really one true source for this. AV&V, through the outstanding customer support from the great folks at Goodson."

- Scott Palmer, Hillside Motorcycle & Machine, Inc., Munnsville, NY, Goodson Customer since 2004

CYLINDER HEAD REBUILDING  
CLEANING, ASSEMBLY & SAFETY  
SHORT BLOCK REBUILDING  
CRANKSHAFT/ FLYWHEEL GRINDING  
MISCELLANEOUS TOOLS & SUPPLIES  
BRAKE & TIRE CHANGING TOOLS  
MEASURING TOOLS  
V-TWIN & METRIC HARD PARTS

## Plastigage

- Accurately measure bearing clearance
- Color coded by size
- Put a piece on rod or main bearing and torque the cap
- Remove and inspect – width of crushed Plastigage shows clearance
- Use at the workbench or in the vehicle
- 10 per pack

Clearance Range	Jobber	Order No.
.001" to .003" / .025 to .076mm	\$21.99	<b>PG-GREEN</b>
.002" to .006" / .051 to .152mm	21.99	<b>PG-RED</b>
.004" to .009" / .102 to .229mm	21.99	<b>PG-BLUE</b>
10pk. Assortment (5 Green, 3 Red, 2 Blue)	21.99	<b>PG-10PK</b>

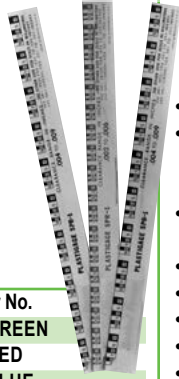

## Hardness Tester

- Calculate Rockwell Hardness quickly and accurately
- Features a steel ball of precise weight and shape which is dropped from an exact height to yield an accurate Rc reading
- Check overheated or repaired crankshaft journals to confirm correct hardness
- Also use on flywheels
- Weighs just 4 oz.
- 9¼" long
- Includes case & instructions
- Order No. **HT-45RC** Jobber \$219.99

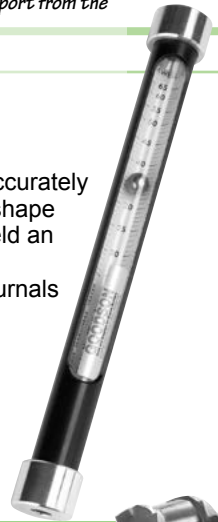

## Crankshaft Machining V-Blocks

- Use to cross-drill journals, keyway cutting, etc.
- Installs easily on Bridgeport-type machine with standard hold downs or bolts and "T" nuts (not included)
- Accepts diameters from 1" to 3¼"
- ¾" wide • Aluminum and steel construction
- Set up at ± .001" • 1 Pair
- Order No. **CVB-100** Jobber \$299.99

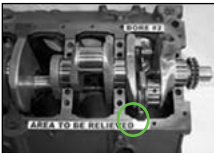
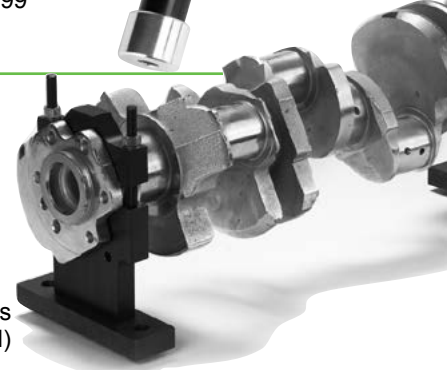

Create a relief in the block for rod #2 at the pan rail area using your normal process.



Place the arbor in main saddles 1 & 2, keeping the flange nearest to the pointer against #2.



Rotate the arbor and adjust the pointer until the tapered end passes freely through the relief with a minimum of clearance.



Lock the pointer in position with the set screw and check the clearance.



Once satisfied, scribe a line on the pointer opposite the set screw.



## Stroker Mimic™

- Lightweight and easy to use
- Eliminates the need to repeatedly install and remove the crankshaft, pistons, the rod assembly and the necessary bearings when clearancing a block for a stroker crank
- Once the Stroker Mimic™ has been set to a particular crank, rod and piston combination, the tool can be marked or measured for future reference

Description	Jobber	Order No.
Stroker Mimic™ Fixture for 350 Blocks	\$167.99	<b>SM-350</b>
Replacement Pointer for SM-350	32.79	<b>SM-351</b>

## Stroke Checker

- Accurately measure strokes up to 6"
- Works with any precision caliper to accurately measure crankshaft strokes
- Measures strokes up to 6" with an accuracy of .001"
- Rigid, hard-anodized aluminum frame is fully adjustable
- Fits almost any crankshaft
- Order No. **CSG-1** Jobber \$178.49



Caliper sold separately

See page 119 for our selection of calipers

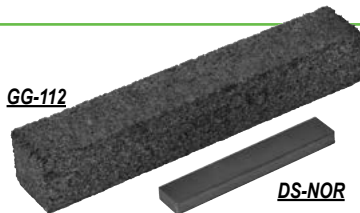

## Hand-Held Dressing Sticks

- Keep your crankshaft grinding wheels cutting clean

Description	Jobber	Order No.
1" x 1" x 6" • Hard Silicon-Carbide • Use to deglaze wheel side • Removes material with pressure	\$19.79	<b>GG-112</b>
¾" x ½" x 3" • Dense, granular Norbide®	62.99	<b>DS-NOR</b>

## Crankshaft Straightening Peening Tool

- Designed for narrow Journals on some new-style V6 crankshafts
- Peen crankshafts in the radius area of damaged journals to straighten
- Long-shank
- Offset-radius face
- 10" long • 0.0625" radius
- 0.125" diameter

Description	Jobber	Order No.
Peening Tool	\$43.79	<b>CPT-062</b>
Safety Glasses	4.99	<b>PGL-21</b>

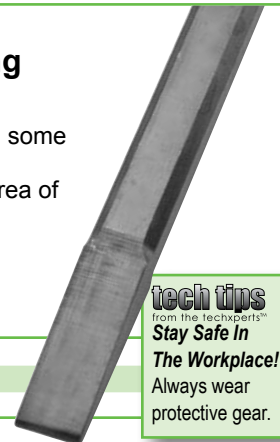

**tech tips**  
from the techexperts™  
**Stay Safe In**  
**The Workplace!**  
Always wear protective gear.

RSV-15A710



RSV-15A709



RVN-43842



RSV-148025

## Crankgrinder Steady Rest Shoes

- Perfect replacements for OE steady-rest shoes on most common machines
- If you can't find your shoe in our chart, fax or email a photocopy or outline of it for immediate identification (1-888-466-3909 or 1-507-452-2907)

Upper Shoe			Lower Shoe	
Thickness	OE No.	Order No.	OE No.	Order No.
<b>PETERSON-Berco</b>				
5/16"	—	RBE-200	—	same as upper
<b>Scledum / DCM TECH</b>				
5/16"	90046	RSC-237350W	—	same as upper
<b>Storm Vulcan</b>				
3/8"	148-25	RSV-148025	—	—
1/4"	15A-170-10	RSV-15A170	—	—
3/8"	15A-70-10	RSV-15A710	15A-70-9	RSV-15A709
3/8"	15C-70-10	RSV-15C710	15C-70-9	RSV-15C709
<b>Schou</b>				
3/8"	—	RSC-15260	—	same as upper
<b>WINONA Van Norman</b>				
475-477	—	—	111-5446	RVN-1115446
475-477	438-42	RVN-43842	—	—
475-477	475-401	RVN-475401	—	—
477	—	—	448-354	RVN-448354
<b>Winona Van Norman / Zanrosso</b>				
210	—	—	815390	RZN-2390
250	815801	RZN-2801	815802	RZN-2802

Jobber \$24.99 each

Jobber \$24.99 each

If you can't find your shoe in our chart, fax or email us a photocopy of it for immediate identification. Fax: 1-888-466-3909 or 507-452-2907.



## Crankshaft Journal Radius Gauge

- 16 radii ... 1/32" to 17/64"
- Measure radii or reground journals quickly
- Blades are clearly marked in 1/64" increments
- Use in holder or remove
- Order No. **RG-16** Jobber \$41.49

Easy to adjust for different heights

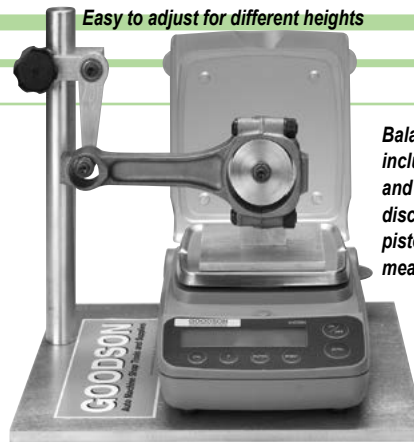

Balancing Stand includes 2"/50.8mm and 2.3"/58.4mm discs to support pistons while measuring

new

Large, easy to read digital display

## Electronic Scales & Balancing Stand

- Easy to read digital display
- Trays measure 5 1/2" x 5"
- Ideal for static balancing parts
- Also use to weigh rotating and reciprocating masses and record the information for dynamic balancing
- Scales feature automatic tare weight correction
- Operates on 9V battery (not included) or 110V converter (included) • Low battery indicator

Capacity	Increments		Jobber	Order No.
	Gram	Ounce		
4100 Gram Scale	1.0	0.100	\$269.99	<b>BS-200</b>
6100 Gram Scale	0.1	0.001	579.99	<b>BS-6100</b>
Rod Balancing Stand			249.99	<b>BS-201</b>

## Heavy Metal

An essential component when balancing rods & pistons to crankshafts to ensure proper engine operation.



HEAVY METAL - TUNGSTEN							
Hole in	Press Fit + in/mm	1.0" Long			1.2" Long		
		Grams	Jobber	Order No.	Grams	Jobber	Order No.
1/2"	.002"/.05	57	\$21.99	HM-57	65	\$23.99	HM-72
3/4"	.002"/.05	122	24.99	HM-122	147	29.99	HM-162
7/8"	.002"/.05	169	32.99	HM-169	198	39.99	HM-198
1"	.002"/.05	227	47.99	HM-227	265	54.99	HM-265

NOTE: Due to market fluctuations, heavy metal prices are subject to change without notice. Please confirm pricing when ordering.

## Universal Quick-Set Crankgrinder Dial Indicator

- 3/8" diameter shaft • 12" long.
- .125" travel, .050" per revolution
- Rotating, lockable bezel graduated in .001" from -.025" to +.025"
- Order No. **MDI-12** Jobber \$369.99



More Dial Indicators on page 119

Starrett

CYLINDER HEAD REBUILDING  
CLEANING, ASSEMBLY & SAFETY  
SHORT BLOCK REBUILDING  
CRANKSHAFT/FLYWHEEL GRINDING  
MISCELLANEOUS TOOLS & SUPPLIES  
BRAKE & TIRE CHANGING TOOLS  
MEASURING TOOLS  
V-TWIN & METRIC HARD PARTS

full service  
...fast



"If you're not sure what to order or if you have any questions, give us a call! We're here from 8am to 5pm Central Time, weekdays to serve you. We can help you get the most from our products and your equipment."

Chris, Goodson ASE-Certified Master Machinist, 29 years of service

CYLINDER HEAD REBUILDING  
CLEANING, ASSEMBLY & SAFETY  
SHORT BLOCK REBUILDING  
CRANKSHAFT/ FLYWHEEL GRINDING  
MISCELLANEOUS TOOLS & SUPPLIES  
BRAKE & TIRE CHANGING TOOLS  
MEASURING TOOLS  
V-TWIN & METRIC HARD PARTS



Outstanding flexibility! Belts conform to the crankshaft better.

**Premium Aluminum-Oxide Crank Polishing Belts**

- J-weight cloth-backing with a high strength mylar joint
- Phenolic resin-over-resin bond • Aluminum oxide abrasive
- Polish better and outlast other standard polishing belts
- Color may vary due to manufacturing process

**Try A Sample Pack!**  
5 of our most popular belts

Belt Size	Jobber	Order No.
64"	\$19.99	PCP-64PAK
72"	19.99	PCP-72PAK

STRAIGHT-EDGE (10 per box)											
Lgth	Wdth	Jobber	240 grit	Jobber	320 grit	Jobber	400 grit	Jobber	600 grit	Jobber	800 grit
60"	¾"	\$39.99	R60x¾x240	\$39.99	R60x¾x320	\$31.99	R60x¾x400	\$31.99	R60x¾x600	\$31.99	R60x¾x800
	1"	39.99	R60x1x240	39.99	R60x1x320	36.99	R60x1x400	36.99	R60x1x600	36.99	R60x1x800
64"	¾"	39.99	R64x¾x240	34.99	R64x¾x320	34.99	R64x¾x400	34.99	R64x¾x600	34.99	R64x¾x800
	1"	44.99	R64x1x240	44.99	R64x1x320	44.99	R64x1x400	44.99	R64x1x600	44.99	R64x1x800
	1½"	43.99	R64x1½x240	39.99	R64x1½x320	—	—	—	—	—	—
	1¾"	49.99	R64x1¾x240	49.99	R64x1¾x320	—	—	—	—	—	—
	2"	51.99	R64x1¾x240	51.99	R64x1¾x320	—	—	—	—	—	—
72"	2"	59.99	R64x2x240	64.99	R64x2x320	—	—	—	—	—	—
	¾"	32.99	R72x¾x240	34.99	R72x¾x320	\$36.99	R72x¾x400	\$36.99	R72x¾x600	\$42.99	R72x¾x800
	1"	43.99	R72x1x240	37.99	R72x1x320	43.99	R72x1x400	43.99	R72x1x600	51.99	R72x1x800
	1½"	45.99	R72x1½x240	54.99	R72x1½x320	—	—	—	—	—	—
	1¾"	48.99	R72x1¾x240	54.99	R72x1¾x320	—	—	—	—	—	—
77"	1¾"	54.99	R72x1¾x240	59.99	R72x1¾x320	—	—	—	—	—	—
	2"	67.99	R72x2x240	64.99	R72x2x320	—	—	—	—	—	—
	¾"	46.99	R77x¾x240	46.99	R77x¾x320	\$37.99	R77x¾x400	\$37.99	R77x¾x600	\$44.99	R77x¾x800
91"	1"	46.99	R77x1x240	46.99	R77x1x320	44.99	R77x1x400	44.99	R77x1x600	49.99	R77x1x800
	¾"	—	—	—	—	41.99	R91x¾x400	41.99	R91x¾x600	41.99	R91x¾x800
91"	1"	—	—	46.99	R91x1x320	46.99	R91x1x400	46.99	R91x1x600	49.99	R91x1x800

All abrasives are guaranteed for 1 year from the original purchase date

**SAVE 10% off jobber!**  
Order 5 or more boxes of crank polishing belts (any combination)

**Micro Finish Scotch-Brite Style Abrasive Rolls**

- Ideal for hand polishing of high-performance crankshafts
- Non-directional polish
- Won't remove material
- Aluminum oxide abrasive with a high-strength resin bond
- Measures: ¾"x10'
- 1 Per Box
- Order No. **GFR-750** Jobber \$29.99



**Premium Micro Polishing Belts**

- Use with our polishing rouge
- Structured Abrasive
- 5 per box

Size (LxW)	Jobber	Order No.
60"x1"	\$36.49	GSW-60x1
64"x1"	36.49	GSW-64x1
70"x1"	47.99	GSW-70x1
72"x1"	39.99	GSW-72x1
77"x1"	39.99	GSW-77x1
Polishing Rouge	11.99	CPR-16

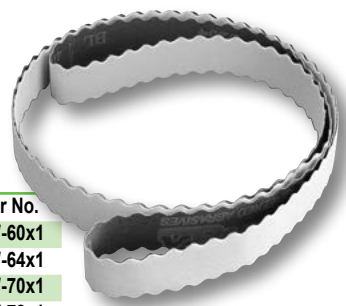

**How to care for your Crankshaft Polishing Belts**

- Always release belt tension when not in use.
- Store belts in a dry, cool area.
- Date your polishing belt boxes when you receive them; abrasives break down over time. Goodson guarantees abrasives for 1 year from the original purchase date.
- Use appropriate accessories with your belts – Grind Aid (**GRA-10**), Polishing Rouge (**CPR-16**) and Abrasive Dresser (**ACB-224**) to improve polishing process and prolong belt life.

**tech tips**  
from the techxperts™

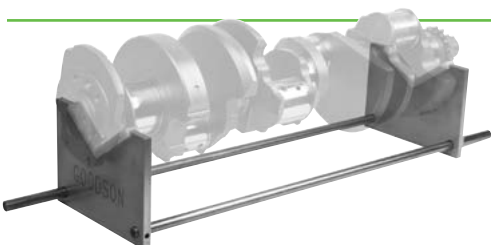

**Professional Measuring & Inspection Stand For Cranks & Cams**

- Length adjusts up to 23" to fit journal spacing
- Rotate work to view or measure
- Solid aluminum frame with self-lubricating, corrosion and chemical-resistant wear surfaces
- Order No. **PMIS-30** Jobber \$124.99

# Crankshaft Polishing

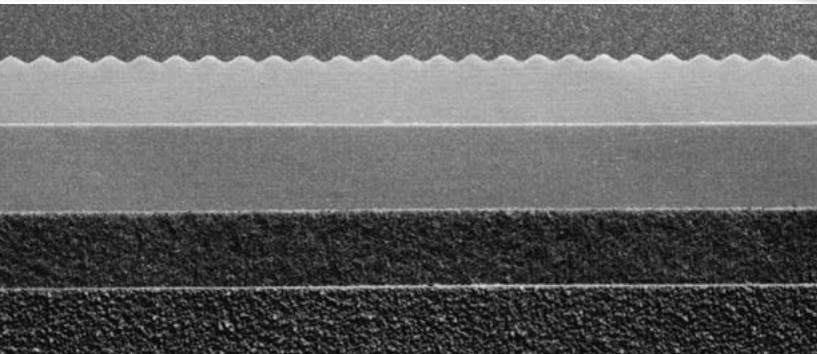

## Standard Polishing Belts

Good quality, flexible, woven cloth-back belts polish better and outlast other general-use belts. New belts can be used to remove minor journal damage without grinding while broken-in belts give a fine finish. Aluminum oxide abrasive. 2-layer glue bond. Colors may vary due to manufacturing.

STANDARD STRAIGHT-EDGE (10 per box)							
Lgth	Width	Jobber	240 grit	Jobber	320 grit	Jobber	400 grit
60"	3/4"	—	—	\$28.99	60x3/4x320	\$28.99	60x3/4x400
	1"	\$31.99	60x1x240	31.99	60x1x320	31.99	60x1x400
64"	3/4"	29.99	64x3/4x240	29.99	64x3/4x320	29.99	64x3/4x400
	1"	36.99	64x1x240	36.99	64x1x320	36.99	64x1x400
	1 1/2"	42.99	64x1 1/2x240	—	—	—	—
	1 3/4"	49.99	64x1 3/4x240	49.99	64x1 3/4x320	—	—
70"	2"	54.99	64x2x240	54.99	64x2x320	—	—
	3/4"	—	—	31.99	70x3/4x320	—	—
	1"	36.99	70x1x240	36.99	70x1x320	36.99	70x1x400
72"	1 1/4"	—	—	39.99	70x1 1/4x320	—	—
	3/4"	32.99	72x3/4x240	32.99	72x3/4x320	32.99	72x3/4x400
	1"	38.99	72x1x240	38.99	72x1x320	38.99	72x1x400
	1 1/4"	49.99	72x1 1/4x240	49.99	72x1 1/4x320	—	—
	1 3/4"	59.99	72x1 3/4x240	49.99	72x1 3/4x320	—	—
77"	2"	63.99	72x2x240	63.99	72x2x320	—	—
	3/4"	—	—	34.99	77x3/4x320	—	—
	1"	41.99	77x1x240	41.99	77x1x320	41.99	77x1x400
	1 3/4"	—	—	69.99	77x1 3/4x320	—	—
91"	2"	—	—	65.99	77x2x320	—	—
	3/4"	35.99	91x3/4x240	35.99	91x3/4x320	—	—
	1"	43.99	91x1x240	43.99	91x1x320	43.99	91x1x400
	1 1/4"	—	—	56.99	91x1 1/4x320	—	—
	1 3/4"	—	—	63.99	91x1 3/4x320	—	—
	2"	—	—	66.99	91x2x320	—	—

All abrasives are guaranteed for 1 year from the original purchase date

## SAVE 10% off jobber!

Order 5 or more boxes of crank polishing belts (any combination)



## Standard Scalloped Edge Crankshaft Polishing Belts

- 10 per box • 320 grit • 1" wide
- Ideal for radius polishing

Length	Jobber	Order No.
64"	\$34.99	S64x1x320
72"	36.99	S72x1x320
91"	56.99	S91x1x320

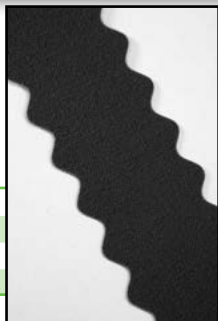

## Fine Finish

- Aluminum-oxide • Flexible, woven back
- 2-layer resin bond
- Very aggressive
- Sharper grains cut faster without sacrificing finish • The Blue Backed Belt

### Fine Finish (10 per box)

Lgth	Width	Jobber	320 grit	Jobber	400 grit
60"	1"	\$39.99	G-60x1x320	\$39.99	G-60x1x400
64"	1"	39.99	G-64x1x320	39.99	G-64x1x400
72"	1"	43.99	G-72x1x320	43.99	G-72x1x400
77"	1"	47.99	G-77x1x320	47.99	G-77x1x400
91"	1"	69.99	G-91x1x320	69.99	G-91x1x400

## Scotch-Brite Style Micro Finish

- Rigid, 3-dimensional back • Resin bond • Aluminum-oxide abrasive • Non-directional finish

### Micro-Finish (1 per box)

Lgth	Width	Jobber	Order No.
60"	3/4"	\$29.99	GFB-60 x 3/4
	1"	29.99	GFB-60 x 1
64"	3/4"	29.99	GFB-64 x 3/4
	1"	29.99	GFB-64 x 1
70"	3/4"	29.99	GFB-70 x 3/4
	1"	29.99	GFB-70 x 1
72"	3/4"	29.99	GFB-72 x 3/4
	1"	29.99	GFB-72 x 1
77"	1"	29.99	GFB-77 x 1
	91"	29.99	GFB-91 x 1

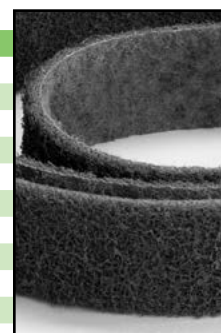

## Scotch-Brite Style Super-Micro Finish

- Produces a mirror-like non-directional finish • Resin bond
- Silicon-Carbide abrasive • For final finish

### Super-Micro Finish (1 per box)

Lgth	Width	Jobber	Order No.
60"	3/4"	\$27.99	SGFB-60 x 3/4
	1"	29.99	SGFB-60 x 1
64"	3/4"	30.99	SGFB-64 x 3/4
	1"	30.99	SGFB-64 x 1
70"	3/4"	30.99	SGFB-70 x 3/4
	1"	30.99	SGFB-70 x 1
72"	3/4"	31.99	SGFB-72 x 3/4
	1"	32.99	SGFB-72 x 1
77"	3/4"	32.99	SGFB-77 x 3/4
	1"	33.99	SGFB-77 x 1
91"	3/4"	35.99	SGFB-91 x 3/4
	1"	35.99	SGFB-91 x 1

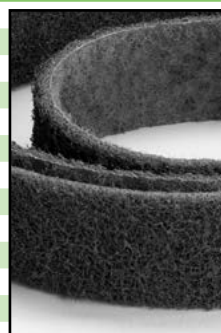

## Abrasive Cork Super-Fine Finish

- Satin finish • Won't disturb polished radii • Silicon-carbide

### Abrasive Cork (1 per box)

Lgth	Width	Jobber	Order No.
64"	3/4"	\$14.99	CPB-64-3/4
	1"	14.99	CPB-64-1
70"	3/4"	14.99	CPB-70-3/4
	1"	14.99	CPB-70-1
72"	3/4"	14.99	CPB-72-3/4
	1"	14.99	CPB-72-1
77"	3/4"	14.99	CPB-77-3/4
	1"	14.99	CPB-77-1
91"	3/4"	14.99	CPB-91-3/4
	1"	14.99	CPB-91-1



**tech tips** Store belts and abrasives in a dry, moisture free area.  
from the techperls™

secure online ordering at [www.goodson.com](http://www.goodson.com)

CYLINDER HEAD REBUILDING  
CLEANING, ASSEMBLY & SAFETY  
SHORT BLOCK REBUILDING  
CRANKSHAFT/FLYWHEEL GRINDING  
MISCELLANEOUS TOOLS & SUPPLIES  
BRAKE & TIRE CHANGING TOOLS  
MEASURING TOOLS  
V-TWIN & METRIC HARD PARTS



"You always get more than great products from us ... you also get great service and grfeat value!"

- Craig, Goodson Shipping/Receiving, 1 year of service

CYLINDER HEAD REBUILDING  
CLEANING, ASSEMBLY & SAFETY  
SHORT BLOCK REBUILDING  
CRANKSHAFT/ FLYWHEEL GRINDING  
MISCELLANEOUS TOOLS & SUPPLIES  
BRAKE & TIRE CHANGING TOOLS  
MEASURING TOOLS  
V-TWIN & METRIC HARD PARTS

## Crankshaft Polishing Starter Kit

Includes 1 each of:

- Grind Aid,
- Polishing Rouge,
- Abrasive Dresser and
- 5-Pack of our most popular 72" belts
- Order No. **CP-KIT** Jobber \$57.99

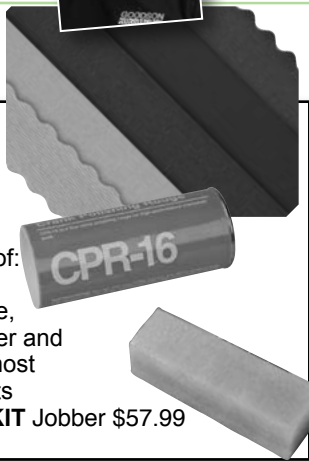

## Grind Aid

- Cools and lubricates
- Reduces loading-up and grain fracturing
- Belts produce a better finish & last up to twice as long
- Use only on cloth-back belts such as those shown on pages 98 & 99
- Order No. **GRA-10** Jobber \$16.99



## Polishing Rouge

- Produces high luster finish
- Use with light pressure, for cork or fine grit polishing to finish crank journals perfectly
- Hard, dry compound becomes viscous with heat
- White • 16 oz. / 454 g
- Order No. **CPR-16** Jobber \$11.99

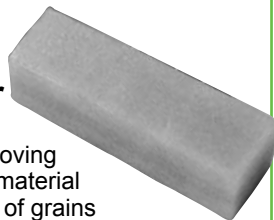

## Abrasive Dresser

- Prolongs belt life
- Hold at 45° angle on moving belt to remove foreign material
- Restores cutting ability of grains
- 2" x 2" x 4" / 51 x 51 x 102mm
- Order No. **ACB-224** Jobber \$17.99

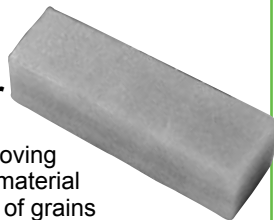

## Heavy Duty Steel Stamps

- For hard materials
- Order in sets or individually
- For a single stamp, state character desired after Order No.
- Example: **SCH-1/4(A)** Single Character stamp, 1/4" size, Letter "A"



Number Sets			
Char. Size	Shank Size	Jobber	Order No.
1/8"	5/16"	\$44.99	SFH-1/8
3/16"	3/8"	49.99	SFH-3/16
<b>Single Characters</b>			
3/16"	3/8"	\$8.99	SCH-3/16
1/4"	7/16"	8.99	SCH-1/4

Special and custom orders are available, call 1-800-533-8010

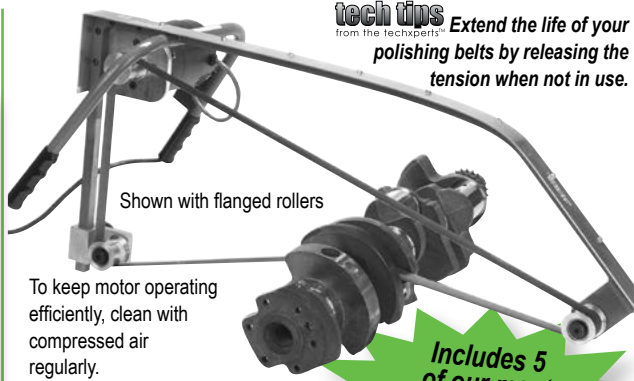

Shown with flanged rollers

To keep motor operating efficiently, clean with compressed air regularly.

**American Made**

## 72" Crankshaft Polisher

- Flex resistant steel frame
- Weighs 15 lbs. (6.8 kg)
- Crowned rollers keep snug belt running true
- 1" nominal = 1.625"
- 2" nominal = 2.625"
- Specify flanged or unflanged rollers when ordering

### Roller Width

Nominal	Actual	HP	Max. RPM	Jobber	Order No.
1"	1.625"/41mm	1/2	10,000	\$ 999.99	PCP-1072
2"	2.625"/67mm	1/2	10,000	1049.99	PCP-1072-2

### Replacement Parts and Rollers

Part	Roller Width	Jobber	Order No.	Includes
Flanged Roller Sets (3 piece set)	1"	\$144.99	PCP-1	▼
	2"	169.99	PCP-2	▼
Unflanged Roller Sets (3 piece set)	1"	144.99	PCP-1S	▼
	2"	194.99	PCP-2S	▼
Flanged Drive Roller	1"	54.99	PCP-1D	1
Fits 3/8" shaft - 1 ea.	2"	57.99	PCP-2D	1
Flanged Roller Assembly 3/8" x 16 thread - 1 ea.	1"	57.99	PCP-1F	2
	2"	79.99	PCP-2F	2
Unflanged Roller Assembly 3/8" x 16 thread - 1 ea.	1"	64.99	PCP-1-1EA	2
	2"	69.99	PCP-2-EA	2
Bearing - 1 ea.		13.99	PCP-BRG	
Replacement Switch		25.29	PCP-SWITCH-72	
Replacement Motor		599.99	PCP-MOTOR-72	



**tech tips** from the techxperts®  
Extend the life of your polishing belts by releasing the tension when not in use.

Includes 5 of our most popular 72" Belts (PCP-72PAK)

## 220 Volt, 50 cycle Motor Export Model

### Roller Width

Nominal	Actual	HP	Max. RPM	Jobber	Order No.
1"	1.625"	1/2	10,000	\$1049.99	PCP-1072E
2"	2.625"	1/2	10,000	1049.99	PCP-1072-2E
Replacement Motor				569.99	PCP-1072E-M



## Crank Welding Rods

- 3 diameters available
- Each rod is 12 1/2" long and cuts off easily
- Sharpen ends with your existing pencil sharpener
- 5 Crank Welding Plug Rods per pack

Size	Jobber	Order No.
.250"	\$15.79	CWPR-250
.312"	15.79	CWPR-312
.375"	15.79	CWPR-375

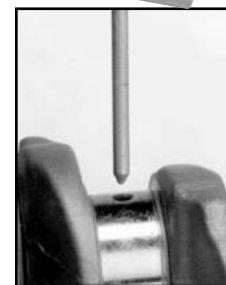

## Dampener Installer

- Install harmonic dampeners without thrust bearing damage
- Screw tool into hole in the crankshaft end
- Use the nut and thrust bearing to draw the harmonic dampener onto the crankshaft snout
- Fits 7/16" x 20" and 1/2" x 20" holes • 3 piece set
- Order No. **DIT-2**  
Jobber \$74.29

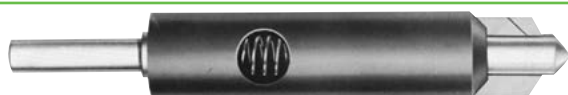

## Eliptibur Tool

- Fastest, safest way to chamfer crank oil holes
- Simplify deburring and chamfering of angularly drilled holes on cylindrical surfaces
- Easily produces a chamfer of relative uniformity and depth
- Self-centering, spring loaded pilot
- Includes one replaceable blade
- For 30Rc or softer crankshafts

Description	Jobber	Order No.
Eliptibur Tool (1 blade included)	\$259.99	<b>EBT-15</b>
Replacement Blades	39.99	<b>EBT-15B</b>

## Flywheel Saver Shims

Many clutch linkages aren't adjustable, so you must return the flywheel friction surface to original position after resurfacing or faulty clutch action and possible failure can occur. These shims let you grind a flywheel instead of replacing it. Shims install between the crank flange and flywheel to compensate for .025" or .050" of grinding. View shims on [goodson.com](http://goodson.com)

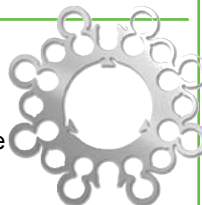

Chrysler	Dia.	Thick	Order No.
5.7, 5.9 (Diesel), 7.5 and 8.1 Liter Engines	5.125"	.025"	<b>FSS-810-25♦</b>
shims have break-off tabs to fit 4.316" & 3.750" ODs		.050"	<b>FSS-810-50♦</b>
Ford			
1.6, 1.9, 2.0, 2.3, 3.0, 3.3, 3.1, 3.8, 3.9 (240ci), 4.1 (250 ci), 4.2 (255ci), 4.7 (289ci), 4.9 (300ci), 5.0 (302ci), 5.8 (351ci)	3.625"	.025"	<b>FSS-468-25♦</b>
		.050"	<b>FSS-468-50♦</b>
5.7 (352ci), 5.9 (360ci), 6.4 (390ci), 6.9 Diesel (420ci), 7.0 (427ci) 7.5 (460ci)	5.000"	.025"	<b>FSS-460-25</b>
General Motors			
2.0, 2.2, 2.5, 2.8, 3.1	3.000"	.025"	<b>FSS-628-25♦</b>
		.050"	<b>FSS-628-50♦</b>
2.3, 3.3, 3.7, 3.8, 4.1, 4.3, 4.6, 5.0, 5.4, 5.7, 6.0, 6.2 Diesel, 6.5, 6.6 Diesel, 6.6, 6.7 (402ci), 7.0 (427ci), 7.4 (454ci)	4.500"	.025"	<b>FSS-857-25♦</b>
		.050"	<b>FSS-857-50♦</b>
2.2, 2.3, 3.8, 4.3	3.750"	.025"	<b>FSS-643-25</b>
4.2, 4.8, 5.3, 6.0 and 6.6 (diesel)	4.056"	.025"	<b>FSS-866-25</b>
Jeep			
2.5, 2.8, 3.1, 4.0 (GM Engine)	3.000"	.025"	<b>FSS-628-25</b>
		.050"	<b>FSS-628-50</b>

Jobber \$11.99

**Note:** Shims marked with ♦ can be stacked to a total thickness of .075"

**new design**

*Extended length to fit extended flange on manual transmissions!*

## Reluctor Ring Installation Tool

- All steel construction
- Adjustable depth for popular flange widths
- Fits Generation III engines: 4.8/LR4, 5.3/LM7 and 6.0/LQ4
- Aligns GM# 12559353 & 12586768 Sensor Rings on the crankshaft in the correct phased position
- Indexes in dowel hole of flange to dowel hole in sensor ring



US PATENT NO. 7,716,827

Description	Jobber	Order No.
Reluctor Ring Installation Tool	\$199.99	<b>RRJ-350</b>
Temperature Indicating Crayon (450° F/232°C)	17.99	<b>TIC-450</b>

**tech tips** from the techexperts™ Heat reluctor ring to 450°F (232°C) then slide it onto the casting. Be sure to deburr all components before beginning assembly. Any sharp edges will cause the reluctor ring to catch on the casting, making assembly impossible.

## Flywheel Grinder Bolt Adaptors

- Replace shoulder bolts with standard hardware
- Low-cost adaptor converts any 1/2" or 7/16" bolt to a 3/4" ID
- Includes countersunk adaptor with bolts for extra clearance



FG-LOCK

Fits	Size	Jobber	Order No.
DCM, Peterson, KW	1/2" x 13	\$33.99	<b>FG-DCP-KIT</b>
WVN	7/16" x 14	33.99	<b>FG-AB-KIT</b>
WVN Table Insert	OD: 5/8" x 11, ID: 7/16" x 14	6.79	<b>FG-LOCK</b>

## Flywheel Radius Cutter Tip Holder

- For WVN/WN FG-5000 • Holder measures 1.5"L with a .312" dia. shank
- Includes 1 indexable FG-3B cutter tip

Description	Jobber	Order No.
Tip Holder	\$119.99	<b>FG-5011</b>
Replacement Tip	9.99	<b>FG-3B</b>

Order 5 or more, take 10% off jobber!

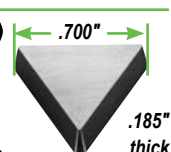

## Flywheel Cutter Tip For Winona Van Norman 570 Rotary Broach

- 3-edge carbide cutting tip for use with the special flywheel attachment
- Order **VN-FW**  
Jobber \$15.99

... another satisfied customer



"Whatever race track we're at and happen to run low on flywheel grinding wheels, they are just a phone call or email away. They'll even ship to wherever we are working. I call that SERVICE with a smile."

- Tim Hyatt, Hyatt Racing Service - Goodson Customer since 1996

CYLINDER HEAD REBUILDING  
CLEANING, ASSEMBLY & SAFETY  
SHORT BLOCK REBUILDING  
CRANKSHAFT/ FLYWHEEL GRINDING  
MISCELLANEOUS TOOLS & SUPPLIES  
BRAKE & TIRE CHANGING TOOLS  
MEASURING TOOLS  
V-TWIN & METRIC HARD PARTS

It is essential, when pulling a dowel, that the tightening sleeve is installed with the flared end toward the collet. This will allow the tightening sleeve to slide over the collet, locking it to the dowel you are removing. Also, be sure to select the correct collet size for the dowel you are removing.

### tech tips

from the techxperts™

## Dowel Puller and Collets

- Slide hammer action removes stubborn dowels
- Use on blocks, heads, flywheels, etc.
- Split collets grip firmly without causing damage
- A high-quality tool that lets you reuse dowel pins
- Choose from SAE or Metric kits
- All items also sold separately

Description	Jobber	Order No.	Incl.
Standard Kit	\$189.99	GA-600	▼
Metric Kit	189.99	GA-600M	▼
Slide Shaft	12.49	GAO-1	x x
Slide Hammer	21.99	GAO-2	x x
Tightening Sleeve	34.99	GAO-3	x x
<b>Gripping Collets</b>			
OD ID mm			
1" .1575" 4.00	\$34.99	GAO-22	x
1" .1875" 4.76	34.99	GAO-4	
1" .1969" 5.00	34.99	GAO-13	x
1" .2362" 6.00	34.99	GAO-14	x
1" .2500" 6.35	34.99	GAO-5	x
1" .2756" 7.00	34.99	GAO-26	
1" .3125" 7.94	34.99	GAO-6	x
1" .3150" 8.00	34.99	GAO-10	x
1" .3750" 9.53	34.99	GAO-7	x
1" .3937" 10.00	34.99	GAO-23	
1" .4375" 11.11	34.99	GAO-8	x
1" .4724" 12.00	34.99	GAO-24	
1" .5000" 12.70	34.99	GAO-9	
1" .5512" 14.00	34.99	GAO-25	
1" .5625" 14.29	34.99	GAO-19	
1" .6250" 15.88	34.99	GAO-20	
1" .6400" 16.26	34.99	GAO-15	
1" .6750" 17.15	34.99	GAO-11	
1" .6875" 17.46	34.99	GAO-17	
1" .7350" 18.67	34.99	GAO-12	
1" .7500" 19.05	34.99	GAO-18	
1" .8000" 20.32	34.99	GAO-16	
Removal Basin	23.99	GAO-21	x x

Parts are stamped for easy identification & reordering

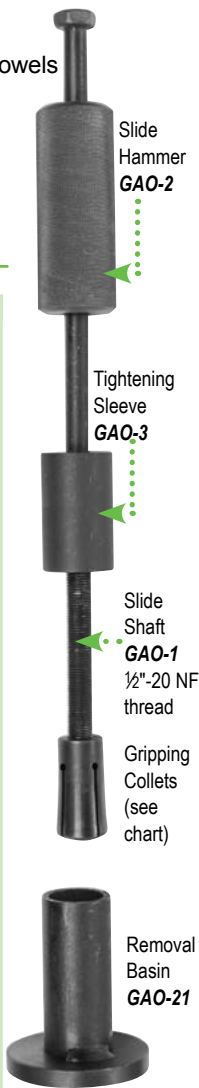

## FlyMaster® Super Abrasive CBN Flywheel Grinding Wheels



- For cast iron
- Light to heavy applications

Dimensions	Abrasive	Shape	Jobber	Order No.
2" / 1 1/2" x 1/8" x 3/8"	CBN	Cup	\$119.99	2H0998
3" x 1 1/4" x 1/4"	CBN	Straight	189.99	261453
3 3/4" / 2 5/8" x 1 1/2" x 1/4"	CBN	Cup	199.99	2371052
5" / 3 3/4" x 1 3/4" x 1/4"	CBN	Cup	209.99	2379270
6" / 4 3/8" x 1 1/8" x 1/4"	CBN	Cup	219.99	2367275*
CBN Dressing Stick 1/2" x 1/2" x 6"			16.99	DS-CBN

\*Most popular application

## Flywheel Depth Gauge with Dial Indicator

- Measure flywheel before and after grinding to maintain proper depth specifications
- Gauge Assembly includes Dial Indicator, Bar & Magnets
- Spindle Extensions sold separately

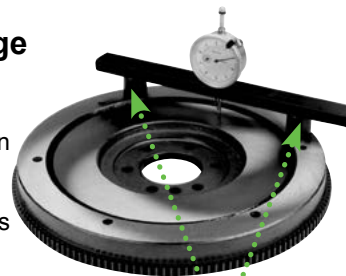

Magnetic feet adjust to flywheel diameter

Description	Jobber	Order No.
Gauge Assembly	\$129.99	FGG-12
Spindle 1.5"	7.99	DIS-1.5
Extensions 2.5"	10.49	DIS-2.5
3.0"	15.79	DIS-3.0

## Pin Pal Puller

- Remove dowels fast
- Adjusts to pull all sizes of dowels
- Vise-grip jaws hold firm while 4 lb. slide hammer forces dowels out
- Also pulls pressed-in hollow tubes or frozen shafts
- Rugged steel construction



Description	Jobber	Order No.
Complete Tool	\$289.99	GA-300
Replacement Jaws	79.99	GA-300E-R



## Grinding Wheel Dressers & Replacement Cutters

Diamond Dresser Tools are available on pages 104-105

Applications	Cutter Assemblies				Replacement Cutters						
	OD	W	Jobber	Order No.	Pieces	Washers	OD	ID	Thick	Jobber	Order No.
VN, Lempco, Storm RT-7Y, 17Y	2.500"	1.625"	\$84.99	GS-10	14 stars	1 w/locking tangs	2.50"	1.50"	.062"	\$22.99	GS-14
Peterson (12mm shaft)	2.375"	1.625"	87.99	GS-17A	8 stars	5	2.375"	1.50"	.093"		
						1 w/locking tangs	1.75"	1.50"	.060"	22.99	GS-17
WVN SM2000, 4000, 5000, 6000C, 6000A, MG3000, 3850	1.250"	.978"	29.99	FG-1165-G	7 stars	none	1.25"	.313"	.095"	7.99	FG-1161-G
Peterson & DCM	2.375"	2.262"	69.99	FG-1070A-G	5 stars		2.375"	1.132"	.1375"	15.99	FG-1070-G
Hand held			49.99	FG-1045-G	1 stone	none	1.50"	.313"	.625"	13.99	FG-1044-G

# Flywheel Grinding Stones



## Flywheel Grinding Coolant

- Formula eliminates rancid coolant
- Synthetic inhibitors • Dilute 30:1

Size	Jobber	Order No.
1 Gal. / 3.78L	\$ 41.99	FG-1101-G
5 Gal. / 18.8L	149.99	FG-1102-G

## Flywheel Grinding Stones

**For best results... choose the right stone from Goodson**

Goodson stones feature 50% more useable abrasive and much stronger construction, yet sell at prices comparable to ordinary stones. With Goodson stones you'll get longer wheel life and lower-cost flywheel grinding.

### Cast Iron:

Cast Iron (soft) flywheels need to be ground with harder stones. Experiment to find the best stone. A good starting point is the **FGW-57**, our best all-around stone for Cast Iron.

### Cast Steel:

Cast Steel (medium) flywheels require medium-hard stones. The **FGW-65** is our best all-around stone for Cast Steel.

### Billet Steel:

Billet Steel (very hard) flywheels need to be ground with softer stones. Our best all-around stone for Billet Steel is the **FGW-50-2**. It's our most friable and free-cutting, requiring minimal dressing.

See the Goodson Tech Library at [goodson.com](http://goodson.com) for more tips on choosing the right Flywheel Grinding Stone.

## Mounting Adaptor For Small Diameter Stones

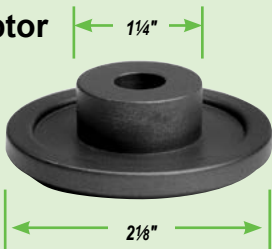

- Many flywheel grinders have lower mounting flanges that won't fit inside 3" and 4" diameter flared-cup stones
- Use this adaptor to avoid damage when mounting small stones
- Fits most small diameter stones
- Order No. **FG-FLANGE** Jobber \$11.99

**10% off jobber!**  
Order 5 or more flywheel grinding stones (any combination)



**tech tips**  
from the techexperts™

Be sure to use ample coolant to flush away swarf and help the stones perform better.



More Flywheel Stones on page NP-5

## CAST IRON (Passenger cars, light trucks)

Size	Description	Jobber	Order No.
6"-4 1/2" x 2 5/8" x 1 1/4"	Harder than FGW-57, lasts longer, black	\$49.99	FGW-67
6"-4 1/2" x 2 5/8" x 1 1/4"	Best all-around for cast iron, black	49.99	FGW-57
6" x 2 1/2" x 1 1/4"	Straight-sided FGW-57, black	48.99	FGW-57S
6"-4 1/2" x 2 5/8" x 1 1/4"	Softer than FGW-57, grinds faster, black	44.99	FGW-47
6"-4 3/4" x 2 7/8" x 1 1/4"	Silicon-carbide, ideal for top fuel, black	44.99	FGW-37
4"-3" x 2" x 1 1/4"	Small diameter FGW-57, black	51.99	FGW-61
4"-3" x 2" x 1 1/4"	Small diameter FGW-37, black	29.99	FGW-37A
3" x 2" x 1 1/4"	Green Silicon-Carbide, Premium	27.99	FGW-93

## CAST STEEL (Industrial, agricultural, OTR trucks)

Size	Description	Jobber	Order No.
6"-4 1/2" x 2" x 1 1/4"	Harder than FGW-65 lasts longer, lt. gray	\$59.99	FGW-53
6"-4 1/2" x 2 5/8" x 1 1/4"	Best all-around for Cast Steel, speckled	89.99	FGW-65
6"-4 1/2" x 2 5/8" x 1 1/4"	Slightly softer than FGW-65, black	47.99	FGW-495
4"-3" x 2" x 1 1/4"	Small diameter FGW-65, speckled	43.99	FGW-69
6"-4 1/2" x 2 5/8" x 1 1/4"	Softer than FGW-65, grinds faster, black	74.99	FGW-49

## BILLET STEEL (Import vehicles, high-performance)

Size	Description	Jobber	Order No.
6"-4 1/2" x 2 5/8" x 1 1/4"	Harder, ruby stone, lasts longer	\$79.99	FGW-64
6"-4 1/2" x 2 5/8" x 1 1/4"	Harder, pink stone, lasts longer	87.99	FGW-62-1
6"-4 1/2" x 2 1/2" x 1 1/4"	Harder than FGW-50-2, white	59.99	FGW-50
6"-4 1/2" x 2 1/2" x 1 1/4"	Best all-around for Billet Steel	74.99	FGW-50-2
4"-3 1/2" x 1 1/2" x 1 1/4"	Harder, pink stone, lasts longer	39.99	FGW-63-1
4"-3" x 2" x 1 1/4"	Taller than FGW-56, more abrasive, white	44.99	FGW-306
4"-3 1/2" x 1 1/2" x 1 1/4"	Premium	34.99	FGW-56P
4"-3 1/2" x 1 1/2" x 1 1/4"	Small diameter FGW-50	29.99	FGW-56
3"-2 1/4" x 1 1/4" x 3/4"	Small diameter, light gray	27.99	FGW-59
3" x 2" x 1 1/4"	Sugar white stone	24.99	FGW-92

**NOTE:** Due to manufacturing process, colors may vary.

All abrasives are guaranteed for 1 year from original purchase date.

**10% off jobber!**

Order 5 or more flywheel grinding stones (any combination)



## Flywheel Grinding Stones for Small Arbors and Special Machines

Use	Shape	Diameter	Height	Jobber	Order No.
Winona VanNorman 444 Rotary Grinder - 7/8" Arbor	Flared	5"-4"	3"	\$129.99	GCV-544
Winona VanNorman 570 Rotary Broach - 15/16" Arbor	Flared	5"-3 3/4"	1 3/4"	\$84.99	GCV-305

All abrasives are guaranteed for 1 year from original purchase date



CYLINDER HEAD REBUILDING ASSEMBLY & SAFETY CLEANING SHORT BLOCK REBUILDING CRANKSHAFT/ FLYWHEEL GRINDING MISCELLANEOUS TOOLS & SUPPLIES CHANGING TOOLS MEASURING HARD PARTS



"Our goal is to serve you faster and better than anyone else in the industry. We ship the same day we receive your order so you don't have to wait any longer than necessary. And, remember, if you need your order in a hurry, Goodson can ship it overnight, 2-day or any other way. Just tell us when you need it and we'll get it there."

- Jon, Texas Customer Service, 21 years of service

shown at approximately full size

CYLINDER HEAD  
REBUILDING

CLEANING,  
ASSEMBLY & SAFETY

SHORT BLOCK  
REBUILDING

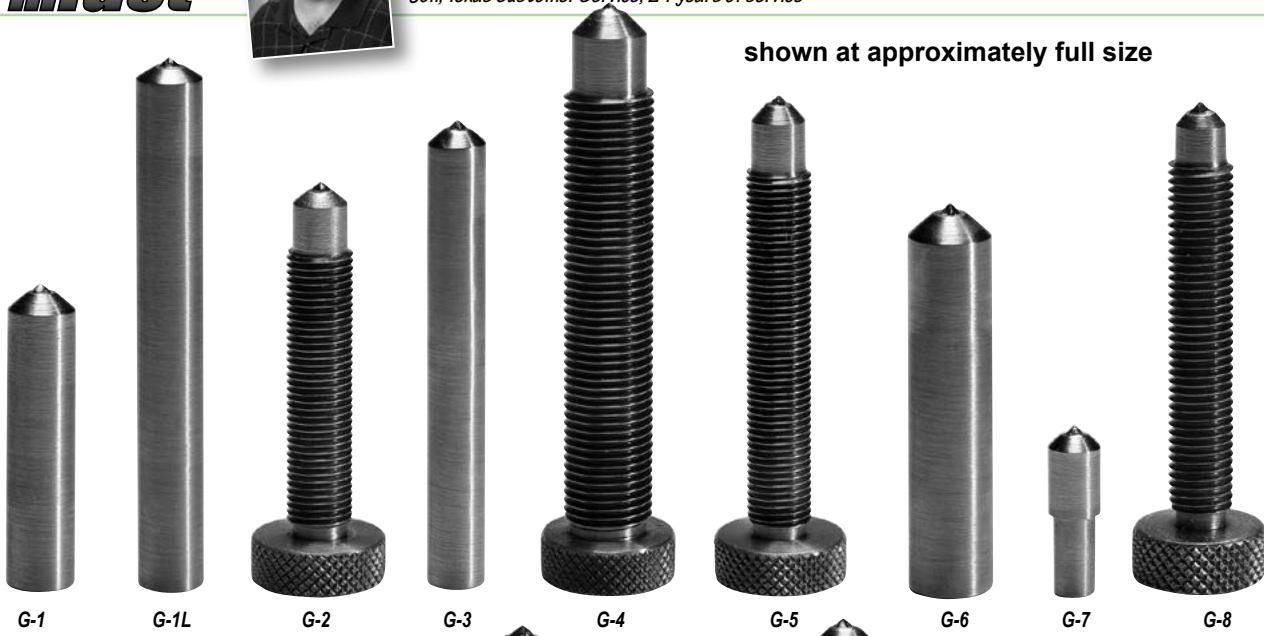

G-1

G-1L

G-2

G-3

G-4

G-5

G-6

G-7

G-8

CRANKSHAFT/  
FLYWHEEL GRINDING

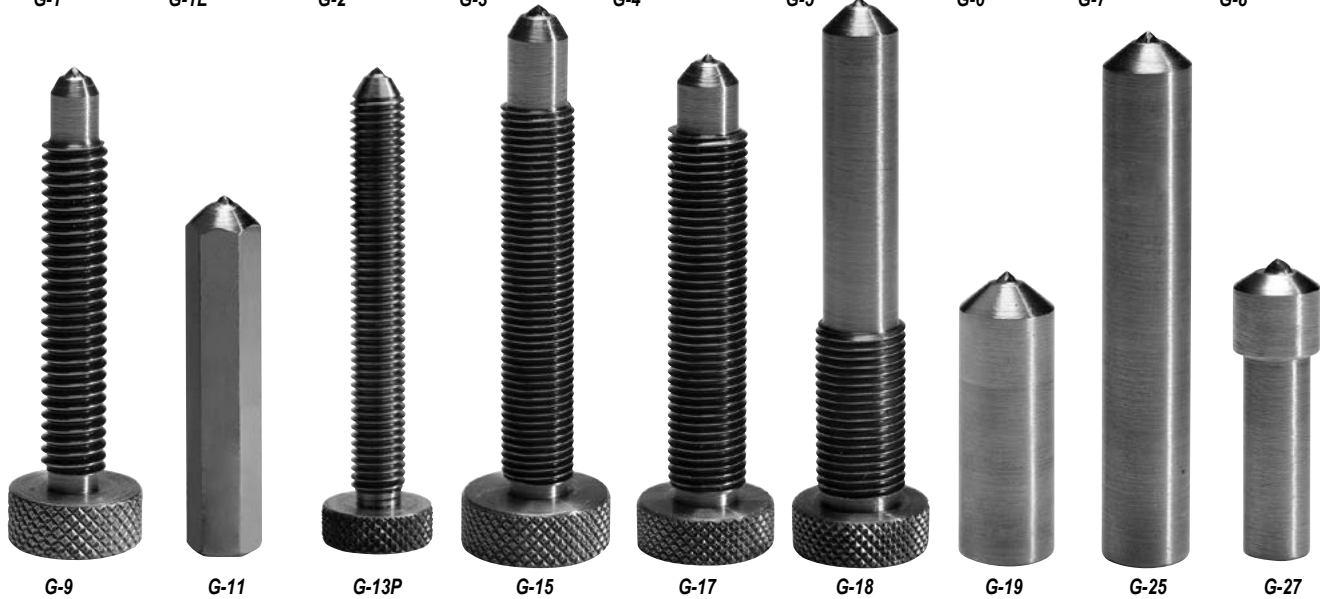

G-9

G-11

G-13P

G-15

G-17

G-18

G-19

G-25

G-27

MISCELLANEOUS  
TOOLS & SUPPLIES

BRAKE & TIRE  
CHANGING TOOLS

MEASURING  
TOOLS

V-TWIN & METRIC  
HARD PARTS

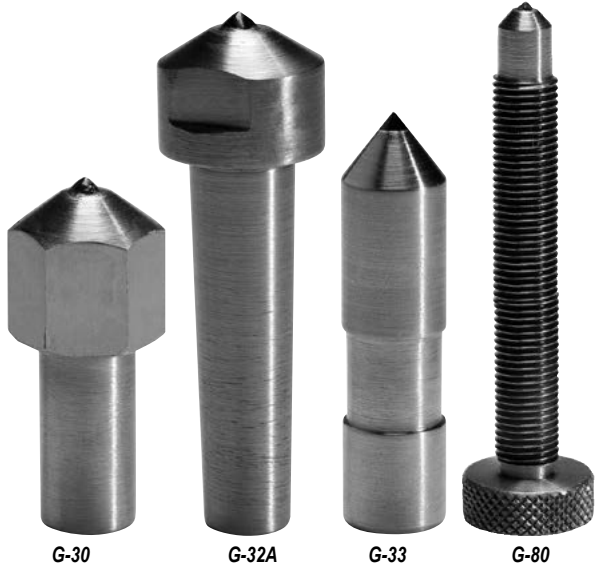

G-30

G-32A

G-33

G-80

**Diamond:** Selected for very high point definition.

A sharper diamond cuts faster and gives a superior finish.

**Matrix:** Matrix material is bronze or copper-based for a tight hold on the diamond & high heat transfer.

**Holder:** Cold rolled steel. Threaded types have precision threads over a long distance to screw easily into tool holders and support cutting point firmly to prevent vibration.

**Diamonds are stamped for easy identification and re-ordering**



### Premium Diamond Resetting Service:

Send in your worn premium diamonds for fast resetting. Prices quoted upon request. Reset when wear facets exceed 1/16" on a 1/2 to 3/4 carat diamond and 1/8" on a 1 carat or larger.

## Diamond Dressers for most shop machines are in stock and ready-to-ship

A diamond tool is only as good as the diamond itself. GOODSON diamonds are furnished by the most respected supplier in the U.S. Each is subjected to a microscopic examination by experts and must meet strict standards to be accepted. This rigorous inspection and careful control during manufacturing assures consistent high quality. Our diamond tools deliver the highest levels of performance and longevity.

In addition to our standard diamond tools, GOODSON stocks a wide selection of Premium Quality diamonds. These diamonds last longer and improve wheel performance. They stay sharp longer and have more points so they can be reset more times. Because of this quality, they will dress harder wheels and wheels will need to be dressed less frequently. If you don't see the diamond you need in a premium quality, call 1-800-533-8010 for a special order.

	Machine	Description	Carat	Radiac #	Jobber	Standard	Jobber	Premium
Valve Refacers	B&D, Skil, Sioux™, Thor, VanDorn, WVN	3/8"x1 1/8"	1/8	2335660	\$ 33.99	G-1	\$ 67.99	G-1P
	Kwik-Way, Tobin Arp (S&D)	5/16"x2 1/2"	1/8	2335662	36.79	G-3	—	—
	Kwik-Way, Valve Master (1714)	1/2"x3 1/4" 20NF	1/8	—	37.79	G-4	—	—
	Sioux™ (1713, 1715), IDL, WVN (CG50, CG80)	3/8"x2 3/4" 24NF	1/8	2335664	36.79	G-5	67.99	G-5P
	IDL, WVN (CG-50, CG-80)	3/8"x3 1/4" 24NF	1/8	—	41.99	G-80	74.99	G-80P
	US	7/16"x2"	1/8	—	36.79	G-6	—	—
	Hall 80, K-W, KO Lee, WVN, KR Wilson	1/4"x1"	1/8	—	39.99	G-7	—	—
	Skil (Talent)	5/16"x2 1/4" 18NC	1/8	—	38.99	G-9	—	—
Kwik-Way	7/16"x2 3/4" 20NF	1/8	2335670	36.79	G-17	67.99	G-17P	
Valve Seat Grinders	B&D, S&D, Van Dorn	3/8"x2 1/4" 24NF	1/8	2335661	37.99	G-2	—	—
	Kwik-Way	1/2"x3 1/4" 20NF	1/8	—	37.79	G-4	—	—
	Sioux™ (1715), K-W (NSG), Thor	3/8"x2 3/4" 24NF	1/8	2335664	36.79	G-5	67.99	G-5P
	Kwik-Way	1/4"x1"	1/8	—	39.99	G-7	—	—
	Hall HD (13-1938P), Skil, Snap-On, B&D	5/16"x2 1/4" 24NF	1/8	2335666	41.99	G-8	66.99	G-8P
	KO Lee, Skil	5/16"x2 1/4" 18NC	1/8	—	38.99	G-9	—	—
	Sioux™ Heavy Duty (1715B, 1719)	3/8" hex RH	1/8	—	59.99	G-11	—	—
	Goodson Universal Wheel Dresser	8mm x 1.25mm	1/8	—	—	—	79.99	G-13P
	Sioux™ Heavy Duty (1715A)	3/8"x2 3/4" 24NF	1/8	—	73.49	G-15	—	—
	Kwik-Way Heavy Duty Wheel Dresser	1/2"x3" 20NF	1/8	2335671	37.79	G-18	67.99	G-18P
Clutch Grinders	Lempco AC, NAC, VAC & Do-ALL	7/16"x2"	1/8	—	36.79	G-6	—	—
Piston Grinders	Van Norman 75, 76 & Relio	3/8"x1 1/8"	1/8	2335660	33.99	G-1	67.99	G-1P
	Storm-Vulcan D-3	7/16"x2"	1/8	—	36.79	G-6	—	—
Drum Lathes	Van Norman (all except 302, 302H)	3/8"x1 1/8"	1/8	2335660	33.99	G-1	67.99	G-1P
	Barret, V.N. 302, 302H	3/8"x3"	1/8	—	34.99	G-1L	—	—
	Lempco	7/16"x2"	1/8	—	36.79	G-6	—	—
	Ammco 5000	1/2"x1 1/2"	1/8	—	37.99	G-19	—	—
Rod Grinders	Sunnen® Rod & Cap Grinder (CRG-500)	3/8"x1 1/8"	1/8	2335660	33.99	G-1	67.99	G-1P
	Storm-Vulcan No. 65 Rod Grinder	1/2"x3 1/4" 20NF	1/8	—	37.79	G-4	—	—
Crank & Cam Grinders	Storm-Vulcan 14, 15, 15A, 15C, 75, 75A	1/2"x3"	3/4	2354244	131.29	G-25	—	—
		1/2"x3"	1	—	179.99	G-25A	—	—
	Scledum	10mmx1 1/8"	3/4	—	132.29	G-27	—	—
		10mmx1 1/8"	1	—	—	—	299.99	G-27AP
	Winona Van Norman/Zanrosso,	7/16"x1 1/4", 5/8" head	3/4	—	132.29	G-30	—	—
	Lempco, Landis	7/16"x1 1/4", 5/8" head	1	—	178.49	G-30A	369.99	G-30AP
	Berco	tapered, step type	1	2354254	179.99	G-32A	299.99	G-32AP
	Berco	tapered, step type	1 1/2	2354255	299.99	G-32B	429.99	G-32BP
	Storm-Vulcan, WVN CG210, 250, 280	1/2"x2" 70° rad. dress	3/4	—	224.99	G-33	—	—
	Universal Cluster Dresser	7/16"x1 1/4", 15°	—	2V9507	99.99	2V9507	—	—
Flywheel Grinder	Kwik-Way 796	7/16"x2"	1/8	—	36.79	G-6	—	—

### tech tips

from the techxperts™

- 1. Set tool at a proper angle.** Position at 10° to 15° from surface. Smaller angles blunt the diamond. Larger angles may cause the wheel to remove matrix material.
- 2. Prevent vibration in the holder.** Any looseness in the tool holder will allow vibration of the tool resulting in poor finish on the wheel.

- 3. Turn coolant on before dressing.** Wheels used wet should be dressed wet. To keep diamond cool, turn coolant on before starting to dress. (If wheel is dressed dry, air-cool diamond between cuts but don't quench with water.)
- 4. Start at highest point.** Wheels often wear unevenly & may have high & low spots. Set tool to dress high spots first, feed in about .001" per pass until done. This prevents overheating & damage.

- 5. Use steady travel.** Uneven travel causes an uneven finish. The best rate is found by experiment, but whatever the rate of travel, it must be even.
  - 6. Turn the tool in the holder.** Turn the tool often to expose new diamond surface to the wheel.
  - 7. Don't bump or drop diamond.** They are hard but brittle, and can be harmed if dropped or bumped.
- CAUTION: Grinding Wheel must never touch the matrix or holder**

CYLINDER HEAD REBUILDING  
 ASSEMBLY & SAFETY  
 CLEANING  
 SHORT BLOCK REBUILDING  
 CRANKSHAFT/FLYWHEEL GRINDING  
 MISCELLANEOUS TOOLS & SUPPLIES  
 BRAKE & TIRE CHANGING TOOLS  
 MEASURING TOOLS  
 V-TWIN & METRIC HARD PARTS



### Deburring Tool

- Swivel tool chamfers sharp, machined edges, bolt holes, and much more
- DT-6 includes cutters for aluminum and cast iron

Description	Jobber	Order No.
Deburring Tool	\$19.99	DT-6
<b>Replacement Cutters</b>		
Steel/Aluminum	\$5.79	DT-10
Cast Iron/Brass	5.79	DT-20

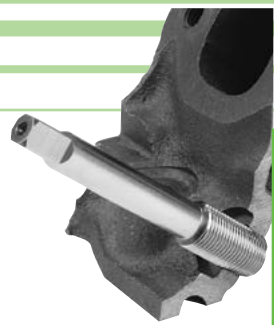

### 14mm Spark Plug Thread Chaser

- Ideal for spark plug hole cleaning
- Re-forms the original material by burnishing, not cutting, and won't create new chips to clean out
- Order No. **SPB-14** Jobber \$99.99



### Burr Buster

- Use on air float tables, seat & guide machines, beds of crankshaft grinders and flywheel grinder tables
- Deburrs gasket surfaces on heads, blocks, manifolds, etc.
- 120 grit premium grade abrasive
- 1½" x 2¾" x 9"
- Order No. **BB-9** Jobber \$23.99



### Bench Grinder Wheels

- 40 and 60 grit for general grinding
- 100 grit for sharpening carbide tools
- Includes bushings to reduce arbor hole from ¾" to ½" PLUS a ⅝" bushing adaptor

Size	Grit	Jobber	Order No.
<b>General Purpose Wheels:</b> For steel and cast iron			
6" x ¾"	60	\$18.99	GG-666
6" x 1"	60	22.99	GG-686
7" x 1"	40	22.99	GG-784
8" x 1"	40	29.99	GG-884
8" x 1"	60	27.99	GG-886
<b>Green Grit Wheels:</b> For sharpening carbide tools			
6" x ½"	100	\$29.99	GGC-641
6" x ¾"	100	27.99	GGC-661
6" x 1"	100	32.99	GGC-681

TR-216-2 TR-216-3

### Premium Tapered Reamers For Tie Rods and Ball Joints

- Use by hand or with a powered driver to deburr or enlarge tapered holes for tie-rod ends or ball joints
- Use in ½" chuck at approximately 40 RPM



OAL	Flute	Small End	Big End	Taper	Jobber	Order No.
5¾"	3¾" long	⅛" dia.	½" dia.	—	\$ 35.99	TR-216-1
6½"	4½" long	⅞" dia.	1" dia.	1½" per ft.	129.99	TR-216-2
6½"	4½" long	1⅝" dia.	1½" dia.	1½" per ft.	154.99	TR-216-3
5"	3" long	½" dia.	1" dia.	2" per ft.	119.99	BJR-2



### Maxxeon WorkStar™ 220 LED Compact Inspection Light

- 6" inspection light weighs just 1 ounce
- Black anodized T6 aluminum body
- Threaded joints have rubber O-ring seals
- Push-button switch is rated at 100,000 cycles and is sealed to keep out dirt and grit
- Runs on 3-AAAA alkaline batteries (included) up to 4 hours
- Order No. **DFL-220** Jobber \$36.79



### Grinding Wheel Star Dressers

Description	Jobber	Order No.
Hand dresser for wheels up to 10" dia.	\$18.99	GS-0
<b>Replacement Cutter Sets</b>		
4 blades, 2 spacers, ¼" ID for GS-0 dresser	\$6.99	GS-00
4 blades, 2 spacers, ½" ID for GS-1 dresser	7.99	GS-11

### Deburring Wheels for Bench Grinders

- Medium-hard wheels are better suited for heat sensitive materials
- Use to clean and polish white metal
- Buff and Blend Wheels deliver the same results as a wire brush but are much safer to work with



Description	Size	Qty.	Jobber	Order No.
Medium-Hard Deburring Wheel	6" x 1" x 1"	1	\$84.49	SCW-68M
Buff and Blend Wheels	6" x ½" x 1"	5	18.99	BBD-65

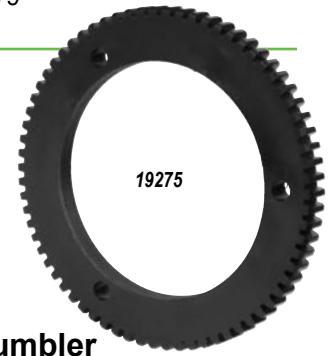

### Parts Tumbler Rebuild Parts For Sioux™ 710 Parts Tumbler

Description	Jobber	Order No.
Steel Gear	\$59.99	271
Fiber Gear	57.79	19275

# Machine Replacement Parts

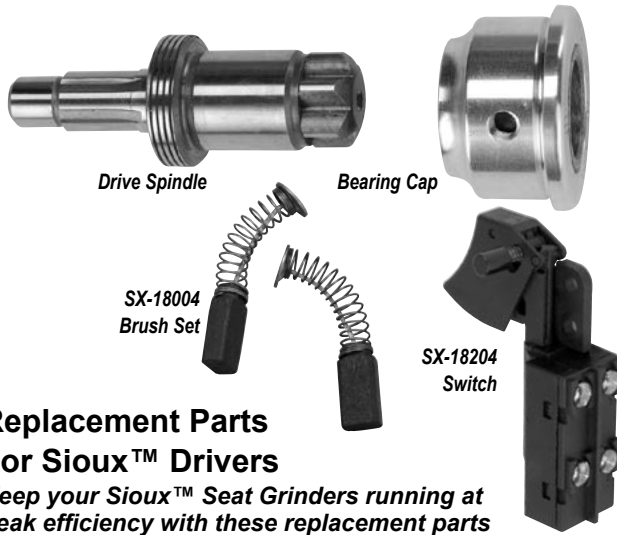

## Replacement Parts For Sioux™ Drivers

Keep your Sioux™ Seat Grinders running at peak efficiency with these replacement parts

- Drive Spindle is spring loaded for dual action grinding
- Brush set is a pair of direct replacement carbon brushes for armature and measures 3/8"x1/2"
- Fit Sioux™ 1710 and 1792 drivers

Description	Jobber	Order No.
Drive Spindle for Sioux™ 1710 Electric	\$84.99	<b>SX-22916</b>
Bearing Cap for Sioux™ 1710 Electric	47.29	<b>SX-23694</b>
Brush Set for Sioux™ 1710 Electric	29.99	<b>SX-18004</b>
Switch for Sioux™ 1710 Electric with plastic handle only	32.49	<b>SX-18204*</b>
Drive Spindle for Sioux™ 1792 Pneumatic	84.99	<b>SX-22939</b>
Bearing Cap for Sioux™ 1792 Pneumatic	44.99	<b>SX-33970</b>

\*Metal handle switch is no longer available

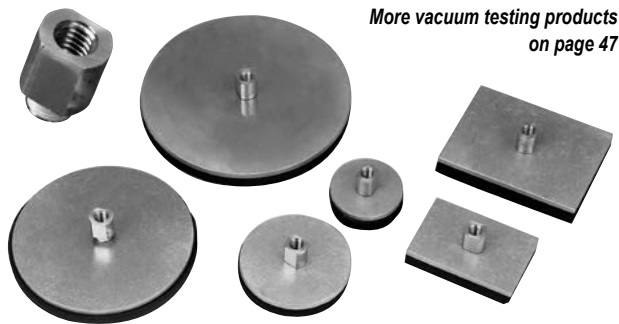

More vacuum testing products on page 47

## Sioux-Style Replacement Vacuum Tester Parts

- For Sioux™ 1630K Tester which is no longer manufactured
- Closed cell foam for an exceptional seal

Sioux-Style Replacement Plates for the 1630K Tester			
Size	OE No.	Jobber	Order No.
2" / 50.8mm dia.	1630-2	\$31.99	<b>SVT-2</b>
3" / 76.2mm dia.	1630-3	31.99	<b>SVT-3</b>
4.75" / 120.7mm dia.	1630-4	31.99	<b>SVT-475</b>
6" / 152.4mm dia.	1630-6	34.99	<b>SVT-6</b>
2"x3" / 50.8 x76.2mm		31.99	<b>SVT-23</b>
3x4" / 76.2 x101.6mm		31.99	<b>SVT-34</b>
Replacement Parts for the 1630K Tester			
Replacement Fitting		\$13.99	<b>DVC-SX</b>
Replacement Gauge		39.99	<b>1630-GAUGE</b>

## Sioux-Style Pilots & Bushings

- Replacement parts for the popular 1716 Seat Wheel Dresser no longer available from Sioux™
- .375" top pilot features a groove to fit Black & Decker holders

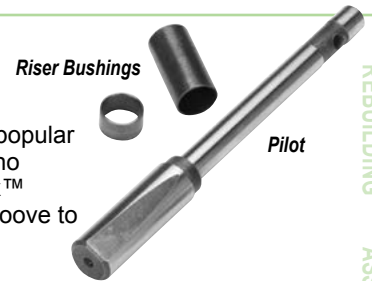

Description	Jobber	Order No.
.385" Top Pilot	\$76.49	<b>1718A</b>
.375" Top Pilot	70.99	<b>1718-BD</b>
.572" Dressing Stand Pilot for Sioux™ 1716 Dresser	76.49	<b>1718-B</b>
Riser Bushings (2) for .385" Pilots	9.99	<b>SK-9-10</b>
Riser Bushings (2) for .572" Pilots	9.99	<b>SK-11-12</b>

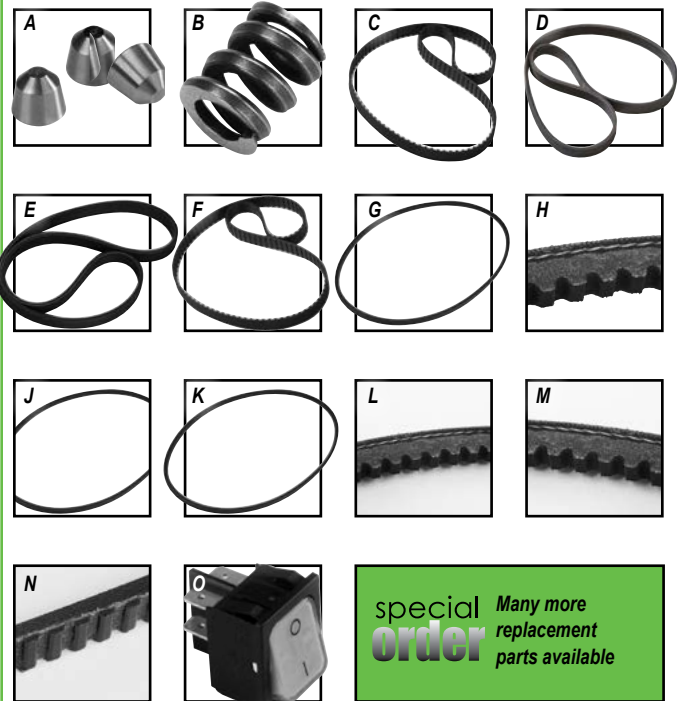

**special order** Many more replacement parts available

## Replacement Parts for Sioux™ Valve Refacers

Description	Fits Model No.	Jobber	Order No.
A- Chuck Balls (3 pc.)	680, 2075	\$199.99	<b>24185</b>
B- Chuck Springs (9 Pc.)	680, 2075	109.99	<b>SX-53615</b>
C- Cog Style 24"x1/2" 120 teeth	680	27.79	<b>SX-14467</b>
D- Serpentine 29 3/8"x1/2" 5 grooves	680	34.99	<b>SX-14471</b>
E- Spindle Belt 28 3/8"x1/2" 5 groove	2075	34.99	<b>SX-65117</b>
F- Chuck Belt 23 3/8"x3/8", 115 teeth	2075	17.99	<b>SX-14473</b>
G- Replacement Belt for Grinding Head	645	54.99	<b>SX-14400</b>
Fits Serial #'s up to 34999(2)			
H- Chuck Belt Fits Serial #'s 34999 & up	645	19.99	<b>SX-14401</b>
(also coolant pump belt for #'s 35217 & up).			
J- Belt for Motor Shaft; Fits Serial #'s up to 34999	645	27.99	<b>SX-14402</b>
K- Coolant Pump Belt; Fits Serial #'s 34999-35216	645	27.99	<b>SX-14403</b>
L- Belt for Motor Shaft; Fits Serial #'s 35000 & up	645	39.99	<b>SX-14445</b>
M- Replacement Belt for Grinding Head;	645	31.99	<b>SX-14453</b>
Fits Serial #'s 3500-58700			
N- Replacement Belt for Grinding Head;	645	37.99	<b>SX-14461</b>
Fits Serial #'s 58701 & up			
O- Replacement Switch (1100V, AC)	2001, 2075	56.79	<b>SX-18221</b>

CYLINDER HEAD  
REBUILDING  
CLEANING,  
ASSEMBLY & SAFETY  
SHORT BLOCK  
REBUILDING  
CRANKSHAFT/  
FLYWHEEL GRINDING  
MISCELLANEOUS  
TOOLS & SUPPLIES  
BRAKE & TIRE  
CHANGING TOOLS  
MEASURING  
TOOLS  
V-TWIN & METRIC  
HARD PARTS



"Be sure to check out the Goodson website ([www.goodson.com](http://www.goodson.com)) for product specials, tech tips, Safety Data Sheets and much more."

- Angie, Advertising Department, 7 years of service

CYLINDER HEAD REBUILDING  
CLEANING, ASSEMBLY & SAFETY  
SHORT BLOCK REBUILDING  
CRANKSHAFT/ FLYWHEEL GRINDING  
MISCELLANEOUS TOOLS & SUPPLIES  
BRAKE & TIRE CHANGING TOOLS  
MEASURING TOOLS  
V-TWIN & METRIC HARD PARTS



### Replacement Parts for CV-616 Honing Machine

Replacement Belts	Jobber	Order No.
Timing Belt	\$115.49	CK-252
Flat Belt	76.79	CK-192A
"V" Belt, Upper	73.49	CK-209A
"V" Belt, Lower	42.27	CK-498A
"V" Belt, Blower	31.49	CK-1267A
Replacement Fiber Planetary Gear Set	57.79	CK-234A

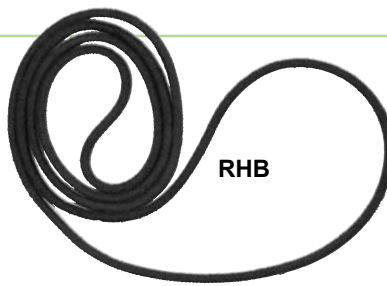

### Goodson Belts for Sunnen® Rod Honing Machines

- Top-quality belts for long life

### tech tips

from the techpers™

You must measure the belt you are replacing. Ordering is based on length not machine model. If your belt size doesn't match one in the chart, order the next size down. For example, if your belt measures 72 1/2", order the 70" Oil Pump Belt. Belts stretch over time so the shorter belt will fit.

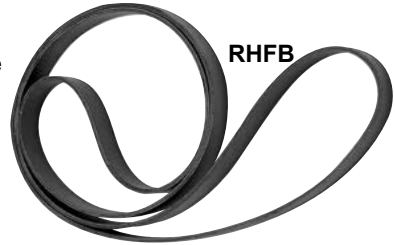

Size	Jobber	Order No.
<b>Oil Pump Belts (.250" round)</b>		
70" / 1.78m	\$94.99	RHB-70
74" / 1.88m	94.99	RHB-74
84" / 2.13m	94.99	RHB-84
85" / 2.16m	94.99	RHB-85
109" / 2.77m	109.99	RHB-109
<b>Flat Belts</b>		
37 1/4" x 5/8" / 945.9x15.9mm	\$ 99.99	RHFB-37
45 1/2" x 5/8" / 1155.7x15.9mm	114.99	RHFB-45
46 1/2" x 5/8" / 1181.1x15.9mm	114.99	RHFB-46



### Valve Refacer Steady Rest Shoes for Sunnen® VR-7000 & VR-8000

- Sold by the pair
- Order No **SUN-1202A** Jobber \$69.99

Steady Rest Shoes for Crankshaft Grinders, page 97

### Quick-Mount Bar Set

- Holds head in place
- Attaches head to roll over cradle
- Fits Goodson Vertical Mill Roll-Over Fixture (pg. 53) as well as many popular seat and guide machines including the Winona PH-2000 and PH-6000
- Order No. **QMB-95** Jobber \$159.99

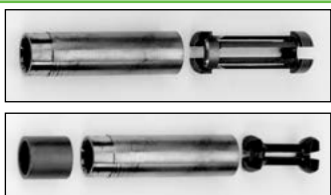
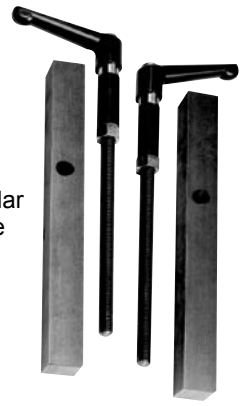

- ◀ Collet is unavailable from OE
- ◀ Replace with two-piece set

### Collet for Black & Decker™ Valve Refacers

- Two-piece set replaces the Black & Decker Twin Grip collet (no longer available)
- Remove the damaged, worn or broken collet and replace with this set
- Accommodates 1/4" (6.35mm) to 3/8" (9.53mm) valve stems
- Order No. **BVR-38** Jobber \$199.99

### Replacement Chuck Belt For Black & Decker

- Chuck belt for the aluminum housing unit
- Replaces OE V-type belt
- .200"/5.08mm thick x 12 3/4"/323.85mm long
- Order No. **BVR-B** Jobber \$26.79



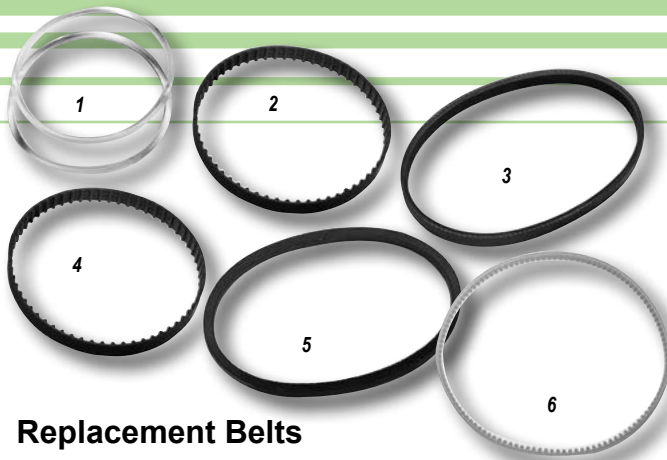

## Replacement Belts For Kwik-Way Valve Refacers

Application	Machine	Jobber	Order No.
1 Spindle Belt 14.5" L "O" Ring - 1 Pr.	SVS II	\$14.49	000-2303-62
2 Chuck Belt 10" Cog, 50 tooth	SVS II	22.29	001-1899-90
3 Spindle Belt 18" Serpentine	SVS	36.79	001-1905-20
4 Chuck Belt 12" Cog, 60 tooth	SVS or VS	22.29	001-1899-99
5 Spindle Belt 16" V-Belt	VS	22.29	001-1900-67
6 Chuck Belt 19" 120 tooth	VS	28.79	001-1900-75

## Replacement Chuck Balls For Kwik-Way Valve Refacers

- Measure chuck ball diameter before ordering to ensure correct replacement
- 6 per set

Diameter	Jobber	Order No.
1/2"	\$41.99	010-2101-27
17/32"	36.79	010-2101-35



enlarged to show detail



**Rebuild Kits**      **Jobber**      **Order No.**  
**For Hex Drive Stone Holder without Spring Plunger**      \$189.99      034-0002-00  
 Includes 2 Bearings, Bearing Sleeve, Sleeve Key, Bearing Lock Nut, Hex Cap & Garter Spring



**For Hex Drive Stone Holder with Spring Plunger**      \$199.99      034-0002-15  
 Includes 2 Bearings, Bearing Sleeve, Sleeve Key, Bearing Lock Nut, Hex Cap & Spring Plunger Assembly



**For Flex Drive Stone Holder**      \$229.99      034-0003-25  
 Includes 2 Bearings, Bearing Sleeve, Heavy Duty Flex Coupling, Inner Sleeve Key & Set Screw

## Replacement Parts for Seat Grinding Drivers

Description	Jobber	Order No.
Trigger Switch	\$39.49	000-1201-20
2 Pc. Brush Set	29.99	003-0072-43

See page 19 for Seat Grinding Drivers

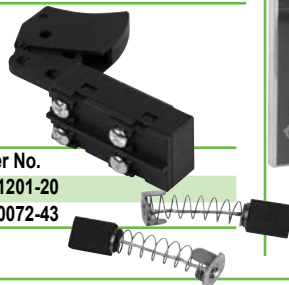

## Automotive Machinist DVDs

Taught by Butch Reilly from Spokane Community College, Easy to understand DVDs are a great addition to any machinist's library.



Title	Run Length	Jobber	Order No.	Incl.
7 DVD Set (one of each below)		\$399.99	DVD-SET	▼
Engine Balancing	138 min.	99.99	DVD-EB	x
Cylinder Honing	46 min.	99.99	DVD-CH	x
Cylinder Boring	52 min.	84.99	DVD-CB	x
Crankshaft Grinding (2 DVD set)	113 min.	99.99	DVD-CG2	x
Using a Micrometer	34 min.	69.29	DMV-1	x
Reconditioning Rods	64 min.	109.99	DRV-1	x

## Power Building Videos on DVD

The **Rotating Assemblies** 2-DVD set includes highly detailed, easy to understand information on parts selection and more. The **Engine Building** 3-DVD set includes a stock Small Block Chevy and a mild performance Small Block Ford.



Description	Length	Jobber	Order No.
Rotating Assemblies	4 hours	\$32.99	DVD-RA2
Engine Building	5 hours	39.99	DVD-EB3

## How to Build and Modify GM LS-Series Engines

This manual includes information on cylinder head preparation, camshafts, rotating assemblies, assembly and induction/nitrous. Order No. **MA-148** Jobber \$29.99

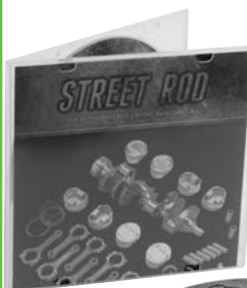

## Street Rod & Performance Engine Building DVD

- Scott Sehr presents the complete parts selection and assembly of a street rod performance engine
- Order No. **ERV-65** Jobber \$59.99



CYLINDER HEAD REBUILDING  
 ASSEMBLY & SAFETY  
 CLEANING  
 SHORT BLOCK REBUILDING  
 FLYWHEEL GRINDING  
 CRANKSHAFT/REBUILDING  
 MISCELLANEOUS TOOLS & SUPPLIES  
 BRAKE & TIRE CHANGING TOOLS  
 MEASURING TOOLS  
 V-TWIN & METRIC HARD PARTS



"If you need engine building tools and supplies, you need Goodson! We're dedicated to providing you with the best quality products, the best value and the best service in the industry."  
- Matt, Receiving - 11 years of service

CYLINDER HEAD REBUILDING  
CLEANING, ASSEMBLY & SAFETY  
SHORT BLOCK REBUILDING  
CRANKSHAFT/ FLYWHEEL GRINDING  
MISCELLANEOUS TOOLS & SUPPLIES  
BRAKE & TIRE CHANGING TOOLS  
MEASURING TOOLS  
V-TWIN & METRIC HARD PARTS

# Brake Lathe Tip Holders

If you're looking for a holder that isn't listed here, call **1-800-533-8010** to see if we can get it for you. All holders include 1 tip.

Machine	Model	Use	OE No.	Jobber	Order No.
Ammco	1000, 2002, 3000, 4000, 4100, 7500, 7700	For Drums 1/2" x 3/8" x 2 1/4"	9872	\$18.99	TAM-41R
All-Tool	747	Use: RT-A series,			
Hoffman	660	negative rake tips			
Performance	6600, 7200, 7100, 7600				
Ammco	3000, 3850, 4000, 4100, 7000 & 6900, 6950 Twin Cutters	For Rotors 3/8" x 3/8" x 1 1/8"	10701	14.99	TAM-701 (R)
Performance	6600, 7200, 7100, 7600	Use: RT-A series,	10702	14.99	TAM-702 (L)
Hoffman	660	negative rake tips			
All-Tool	747				
Ammco	3000, 3850, 4000, 4100, 7000 & 6900, 6950 Twin Cutters	For Rotors 3/8" x 3/8" x 1 1/8"	25968	13.99	TAM-25968 (R)
		Use: RT-3A & RT-3AS series,	25969	13.99	TAM-25969 (L)
		positive rake tips			
Accu-Turn	fits all combination lathes	Drums & Rotors 3/8" x 3/8" x 2 3/4"	433763	14.99	TFM-42R (R)
FMC	600, 601, 700, 701, RotoTruer	Use: RT-AC & RT-FMC series,	433764	14.99	TFM-42L (L)
Hoffman	Perfect 400	positive rake tips			
Bear	1410, 1466, 1467, 1468, 1469, 14781	Drums and Rotors 3/8" x 3/8" x 3"	90495	18.99	TBR-44R (R)
		Use: RT-B series,	90494	18.99	TBR-44L (L)
		negative rake tips			
Ammco	Direction: Left	3/8" x 3/8" x 1 1/8"		27.99	TAM-312L
Hoffman	Direction: Right	3/8" x 3/8" x 1 1/8"		27.99	TAM-312R
Performance, All-Tool		Use: RT-312 series tips			
Ammco	Direction: Left	3/8" x 3/8" x 1 1/8"		26.99	DTAM-312L
Hoffman	Direction: Right	3/8" x 3/8" x 1 1/8"		26.99	DTAM-312R
Performance, All-Tool		Use: RT-64A		87.99	DTAM-SET*
Accu-turn	Direction: Left	3/8" x 3/8" x 2 3/4"		24.99	TFM-312L
FMC, Bear,	Direction: Right	3/8" x 3/8" x 2 3/4"		24.99	TFM-312R
Hoffman, Kwik-Way, Snap-On, etc.		Use: RT-312 series tips			
Accu-turn	Direction: Left	3/8" x 3/8" x 2 3/4"		26.99	DTFM-312L
FMC, Bear,	Direction: Right	3/8" x 3/8" x 2 3/4"		26.99	DTFM-312R
Hoffman, Kwik-Way, Snap-On, etc.		Use: RT-64AC		87.99	DTFM-SET*
Hunter	Set of holders & tips (1 of each)	Use RT-MRH tips		69.99	RT-MRH-SET

\*DTAM-SET & DTFM-SET includes 10 Tips see p. 115

## Measurements for Solid Carbide, Honed Edge Carbide & Titanium Coated Carbide Cutting Tips



### Measure to Find the Right Tip

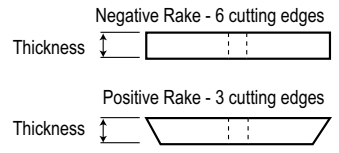
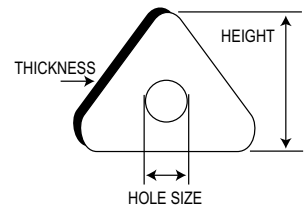
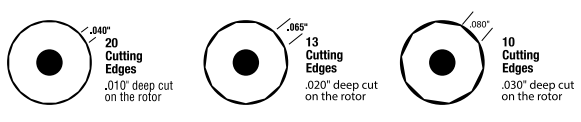

<b>RT-A</b> Height: .350" Thick: .095" Hole: .135" Rake: NEG	<b>RT-3AS</b> Height: .357" Thick: .104" Hole: .127" Rake: POS	<b>RT-3A</b> Height: .343" Thick: .093" Hole: .133" Rake: POS	<b>RT-373</b> Height: .625" Thick: .125" Hole: .117" Rake: POS	<b>RT-AC</b> Height: .445" Thick: .131" Hole: .145" Rake: POS	<b>RT-FMC</b> Height: .452" Thick: .125" Hole: .090" Rake: POS	<b>RT-B</b> Height: .343" Thick: .105" Hole: .130" Rake: NEG
<b>RT-HF</b> Height: .714" Thick: .185" Hole: .200" Rake: NEG	<b>RT-KW</b> Height: .358" Thick: .101" Hole: .125" Rake: POS	<b>RT-H</b> Height: .344" Thick: .125" Hole: .090" Rake: NEG	<b>RT-HNT</b> Height: .312" Thick: .103" Hole: .127" Rake: POS	<b>RT-MRH</b> Diameter: .235" Thick: .125" Hole: .108" Rake: POS	<b>RT-VBG</b> Height: .344" Thick: .098" Hole: .124" Rake: POS	<b>RT-VN</b> Height: .545" Thick: .125" Hole: N/A Rake: POS
<b>RT-VNS</b> Height: .547" Thick: .121" Hole: N/A Rake: POS	<b>RT-VNH</b> Height: .545" Thick: .095" Hole: .135" Rake: NEG	<b>RT-VNA</b> Height: .535" Thick: .188" Hole: .148" Rake: NEG	<b>RT-KWL-T</b> Height: .338" Thick: .100" Hole: .123" Rake: POS	<b>RT-VNP-L OR -R</b> Height: .902" Thick: .100" Hole: N/A Rake: POS	<b>RT-312</b> Diameter: .311" Thick: .100" Hole: .150" Rake: POS	<b>RT-360</b> Height: .311" Thick: .100" Hole: N/A Rake: POS

Tips Are Shown Actual Size

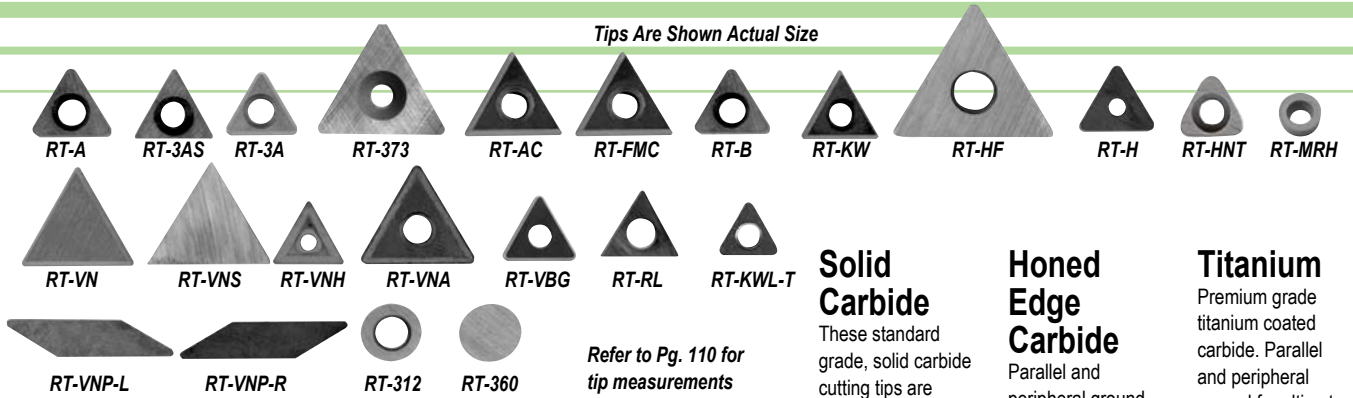

Refer to Pg. 110 for tip measurements

### Solid Carbide

These standard grade, solid carbide cutting tips are parallel ground for resurfacing cast iron drums and rotors.

### Honed Edge Carbide

Parallel and peripheral ground. Honed edges deliver a better finish on cast iron and composite rotors.

### Titanium

Premium grade titanium coated carbide. Parallel and peripheral ground for ultimate performance on cast iron & composite rotors.

**The more you buy, the more you save!**

Order 3 or more 10-packs, save 10% off jobber



Machine	Model(s)	OE No.	Edges	Rake	Screws	Jobber	Order No.	Jobber	Order No.	Jobber	Order No.
Ammco	700, 710, OTC Lathes, 1000, 2002, 3000, 4000, 4100, 7000, 7500, 7700	6914	6	Neg	Yes	\$2.79	RT-A	\$2.99	RT-A-H	\$3.59	RT-A-T
	3850 smaller (1/64") radius	6918	3	Pos	Yes	3.99	RT-3AS	4.59	RT-3AS-H	4.99	RT-3AS-T
	larger (1/32") radius	7681	3	Pos	Yes	3.99	RT-3A	4.59	RT-3A-H	4.99	RT-3A-T
Twin Cutters:	6900,6950 negative rake (std.)	6914	6	Neg	Yes	2.79	RT-A	2.99	RT-A-H	3.59	RT-A-T
	positive rake (standard) 1/64" (finer finish)	6918	3	Pos	Yes	3.99	RT-3AS	4.59	RT-3AS-H	4.99	RT-3AS-T
	positive rake (modified) 1/32" (more durable)	7681	3	Pos	Yes	3.99	RT-3A	4.59	RT-3A-H	4.99	RT-3A-T
	7900	6914	6	Neg	Yes	2.79	RT-A	2.99	RT-A-H	3.59	RT-A-T
Ammco HD	5000, 6000, 6002	5677	3	Pos	No	9.79	RT-373	—	—	—	—
Accu-Turn	All combination disc/drum lathes	433796	3	Pos	Yes	4.59	RT-AC	4.79	RT-AC-H	4.99	RT-AC-T
	On-The-Car Lathes	878051	6	Neg	Yes	2.79	RT-A	2.99	RT-A-H	3.59	RT-A-T
All-Tool	747	3331	6	Neg	Yes	2.79	RT-A	2.99	RT-A-H	3.59	RT-A-T
Bean	B-401, B-410, B-501, B-601	90487	3	Pos	Yes	3.69	RT-FMC	3.99	RT-FMC-H	4.99	RT-FMC-T
Bear	1410,1466,1467,1468, 1469, 1478	2264,72265,772834	6	Neg	Yes	2.79	RT-B	3.99	RT-B-H	—	—
	10-1430, 10-1435	W136	6	Neg	No	9.79	RT-HF	—	—	9.99	RT-HF-T
FMC	600, 601, 700, 701, RotoTruer	90487	3	Pos	Yes	3.69	RT-FMC	3.99	RT-FMC-H	4.99	RT-FMC-T
	505, On-The-Car Lathe	91212	3	Pos	Yes	3.49	RT-KW	3.99	RT-KW-H	4.59	RT-KW-T
Hoffman	660	3331	6	Neg	Yes	2.79	RT-A	2.99	RT-A-H	3.59	RT-A-T
Horvath	All	1605	6	Neg	No	3.99	RT-H	—	—	—	—
Hunter	BL300 On-The-Car Lathe	221580-2	6	Neg	Yes	2.79	RT-A	2.99	RT-A-H	3.59	RT-A-T
	BL-500, BL-501, BL-505	6918	3	Pos	Yes	3.99	RT-3AS	4.59	RT-3AS-H	4.99	RT-3AS-T
	BL-500	221-678-3	3	Pos	Yes	4.59	RT-HNT	—	—	—	—
	Micro Tips of OCL-400 Lathe	221-626-3	3	Pos	Yes	7.69	RT-MRH	—	—	—	—
Kwik-Way	CBL, NCL, SDL Kwik-Lathe OTC Lathe	109-1092-23	3	Pos	Yes	3.49	RT-KW	3.99	RT-KW-H	4.59	RT-KW-T
	Lightening Lathe	109-1092-45	3	Pos	Yes	—	—	—	—	6.99	RT-KWL-T
Performance	6600,7200,7100, 7600	3331	6	Neg	Yes	2.79	RT-A	2.99	RT-A-H	3.59	RT-A-T
Pro-Cut	On-The-Car Lathe	50-701, 50-742	3	Pos	Yes	3.49	RT-VBG	3.99	RT-VBG-H	4.59	RT-VBG-T
RJ West	915D Disc Lathes	W136	6	Neg	No	9.79	RT-HF	—	—	9.99	RT-HF-T
	Perfect 400, 1115HD	W139	3	Pos	Yes	4.59	RT-AC	4.79	RT-AC-H	4.99	RT-AC-T
RTI	BRC35 On-The-Car Lathe	91212	3	Pos	Yes	3.99	RT-3A	4.59	RT-3A-H	4.99	RT-3A-T
Snap-On	YA282,YA277,YA278, YA180 OTC Lathe	109-1092-23	3	Pos	Yes	3.49	RT-KW	3.99	RT-KW-H	4.59	RT-KW-T
Van	204, 204D, 205, 205DC, 415, 243XV	29687	3	Pos	No	3.99	RT-VN	4.99	RT-VN-H	4.99	RT-VN-T
Norman and Rels	Smaller (1/64") radius	—	3	Pos	No	3.99	RT-VNS	4.79	RT-VNS-H	4.99	RT-VNS-T
	Older Model 204	21933	6	Neg	No	4.99	RT-VNH	—	—	—	—
	204, 304, 405	29005	6	Neg	No	6.99	RT-VNA	—	—	6.99	RT-VNA-T
	303,304,305,404,405,V22	304-7167	2	Pos	No	6.99	RT-VNP-L	—	—	7.99	RT-VNP-LT
	204,205,205DR,300,302,333,243,243XV	302-7167	2	Pos	No	6.99	RT-VNP-R	—	—	7.99	RT-VNP-RT
	Rels 2000 rotor	45016, 45021	3	Pos	Yes	5.99	RT-RL	—	—	—	—
VBG	On-The-Car Lathe	50-701	3	Pos	Yes	3.49	RT-VBG	3.99	RT-VBG-H	4.59	RT-VBG-T
Round Tips with hole	Fits TAM-312 and TFM-312 Holders	RT-312,RT-312T	360°	Pos	Yes	5.99	RT-312	—	—	7.99	RT-312T
	solid	Fits TAM-360SET, TFM-360SET, R/JH and CT Holders	CT10	360°	Pos	5.99	RT-360	—	—	7.99	RT-360T

**NOTE:** The table above shows the original-equipment cutting tips for Ammco machines. Most of them use negative-rake tool systems. However, some Ammco machines (especially the 4000 and 7000-series) have been modified in the field by using the TAM-25968 and TAM-25969 positive-rake tool holders (see next page). If your machine is shown above to have 6-edge tips but has 3-edge tips, it has been modified – please order our RT-3A or RT-3AS series tips.

CYLINDER HEAD REBUILDING  
CLEANING, ASSEMBLY & SAFETY  
SHORT BLOCK REBUILDING  
CRANKSHAFT/ FLYWHEEL GRINDING  
MISCELLANEOUS TOOLS & SUPPLIES  
BRAKE & TIRE CHANGING TOOLS  
MEASURING TOOLS  
V-TWIN & METRIC HARD PARTS

# Brake Lathe Tools & Silencers



## Neoprene Brake Lathe Silencer

- Longer lasting than rubber
- Neoprene material resists deterioration associated with standard rubber belts
- 7 weights
- Measures: 34" L x 5/8" W x 3/16" Thick
- Order No. **GT-6030N** Jobber \$19.99

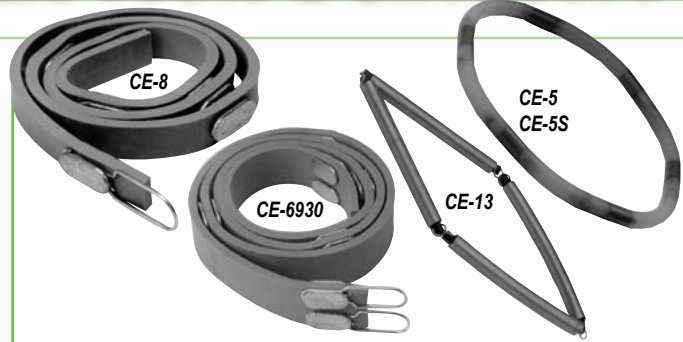

## Silencers For Vented Rotors

Style	Size	OE No.	Jobber	Order No.
Rubber Strap	34" L x 5/8" W x 3/16" thick	6920	\$18.99	<b>CE-8</b>
	36" L x 1 1/4" W x 3/16" thick	6930	34.99	<b>CE-6930</b>
Spring	Fits 6" to 9" rotors		27.99	<b>CE-13</b>
Rubber Tube	9" Diameter, 6 weights		19.99	<b>CE-5</b>
	8" Diameter, 4 weights		19.99	<b>CE-5S</b>

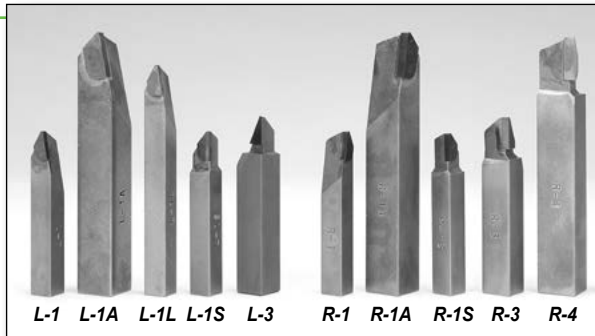

## Brazed Carbide Brake Lathe Tools

- Fit most popular brake drum lathes

### Left Hand Cutting Tools

Size	Application	Jobber	Order No.
3/8" sq. x 2 1/2"	Replaces Bean 43-46L; Bear 23211; Star CB-8; VN 302-7272 for 303, 304, 304H	\$11.99	<b>L-1</b>
5/8" sq. x 4"	Replaces Ammco 5725, for 5000; Star CB-30; VN "Big Brute" for 310-404 Hardspots	19.99	<b>L-1A</b>
3/8" sq. x 3 1/2"	Extra long L-1 for small dia. drums	11.99	<b>L-1L</b>
3/8" sq. x 2 1/2"	Master carbide-tipped with 7° rake angle	14.99	<b>L-1S</b>
1/2" sq. x 2 3/4"	Replaces Ammco 4726 heavy-duty tool Ammco 4726 for 5000 & 6000 dual facing tool and 3000, 4000, 4100 & 7700 lathes	21.99	<b>L-3</b>

### Right Hand Cutting Tools

Size	Application	Jobber	Order No.
3/8" sq. x 2 1/2"	Replaces Bean 43-46R; Bear 20718; Star LB-16; VN 302-7171 for 204, 300, 302, 302H, 333, 243XV; and Barrett & Lempco	\$11.99	<b>R-1</b>
5/8" sq. x 4"	Replaces Ammco 5720 for 5000; Lempco SHD, DH, 530 Kwik-Way Heavy Duty	19.99	<b>R-1A</b>
3/8" sq. x 2 1/2"	Master carbide-tipped with 7° rake angle	14.99	<b>R-1S</b>
1/2" sq. x 2 3/4"	Replaces Ammco 4725 for 3000, 4000, 4100, 7100 drum lathes	14.99	<b>R-3</b>
5/8" sq. x 4"	Replaces Bear 24034; Star CB-35	18.99	<b>R-4</b>

## Hardspot Cutters

### Left Hand

Size	Use	Jobber	Order No.
3/8"x3/8"x2 3/8"	Drums	\$15.99	<b>L-5</b>
	Discs	15.99	<b>L-6</b>

### Right Hand

Size	Use	Jobber	Order No.
3/8"x3/8"x2 3/8"	Drums	\$14.99	<b>R-5</b>
	Discs	14.99	<b>R-6</b>



L-6 L-5 R-5 R-6

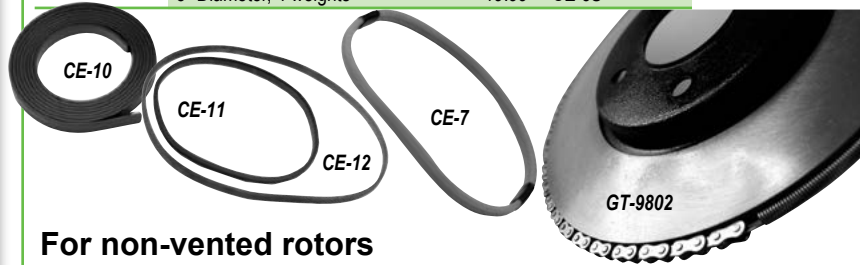

## For non-vented rotors

Style	Size	Jobber	Order No.
Magnetic Strap	48" long	\$ 9.99	<b>CE-10</b>
Rubber Band	6 1/2" dia. x 5/16" W x 3/16" thick	4.99	<b>CE-11</b>
	9 1/4" dia. x 5/16" W x 3/16" thick	4.99	<b>CE-12</b>
Rubber Tube	Fits 6" to 9" rotors	7.99	<b>CE-7</b>
Chain Band	Nickel plated with 4-springs	59.99	<b>GT-9802</b>



## For vented and non-vented rotors

Style	Application	Jobber	Order No.
Clamp-On	For Bench model lathes	\$ 27.99	<b>CE-6</b>
	For On-The-Car lathes	26.29	<b>CE-26</b>
Friction	Most Ammco lathes	157.49	<b>7075</b> ▼
	Replacement Pucks for 7075	14.99	<b>CE-9</b> x
	Replacement Mounting Bracket	17.99	<b>GT-10283</b> x
	Replacement Wrench	6.99	<b>GT-11497</b> x



CE-1, CE-2

## For Drums

Style	Application	Jobber	Order No.
Rubber Strap	Automobiles 5'L x 2 7/8"W x 1/8" thick	\$16.99	<b>CE-1</b>
	Trucks 6'6"L x 2 7/8"W x 1/8" thick	27.99	<b>CE-2</b>

CYLINDER HEAD REBUILDING  
CLEANING, ASSEMBLY & SAFETY  
SHORT BLOCK REBUILDING  
CRANKSHAFT/ FLYWHEEL GRINDING  
MISCELLANEOUS TOOLS & SUPPLIES  
BRAKE & TIRE CHANGING TOOLS  
MEASURING TOOLS  
HARD PARTS

### 1" Arbor for Ammco

- Fits Ammco models 2002, 3000, 4000, 4100, 7000, 7500 and 7700
- 7/8" x LH thread
- Precision ground between centers using only one set-up for the greatest accuracy
- Factory checked for runout of less than .001"
- Heat treated, stress relieved tool steel
- For drums & rotors up to 125#
- Order No. **GT-3101** Jobber \$149.99



### 1HP Motor for Ammco Brake Lathes

- Fits 3000, 4000, 4100, 7000, 7500, & 7700 models
- 208/230/115V • 1725 RPM
- 60Hz
- Order No. **GT-2165** Jobber \$299.99



### Right Angle Drive Assembly for Ammco Brake Lathes

- Fits 3000 & 4000 lathes
- Eliminates radial & axial play
- Order No. **GT-9815** Jobber \$279.99



### 1" Arbor Accessories

Description	Model(s)	Thread	Jobber	Order No.
Arbor Nuts	Fits all Ammco but 1101	7/8" x 9 LH	\$12.99	<b>GT-3102</b>
	All arbors but Ammco	1" x 8 LH	12.99	<b>GT-20442N</b>
Centering Spring			2.99	<b>GT-3110</b>
1" Spacers		Length	Jobber	Order No.
for ALL Brake Lathes		1/2"	\$ 4.99	<b>GT-3125</b>
		1"	12.99	<b>GT-5040</b>
		1 1/2"	13.99	<b>GT-5041</b>
		2"	14.99	<b>GT-5042</b>
		Flexible	26.99	<b>GT-9492</b>

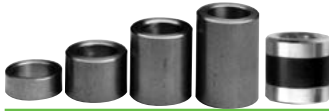

### Replacement Work Light

- 30" adjustable arm
- 5/8" round mounting end
- Uses up to 100W standard base bulb (not included)
- Easily accessible switch
- Fits most Ammco models
- Order No. **GT-7963** Jobber \$89.99



### Replacement Switch for Ammco Brake Lathes

- Easy to install
- Fits most models
- Order No. **GT-7893** Jobber \$10.99

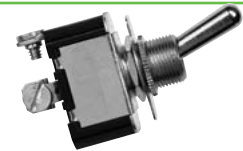

### Ammco Rotor & Drum Feed Screws & Nuts

Description	Jobber	Order No.
Rotor Feed Nut (early)	\$ 25.99	<b>GT-10868</b>
Rotor Feed Nut (late)	25.99	<b>GT-10868X</b>
Drum Feed Nut (all)	43.99	<b>GT-4670</b>
Rotor Feed Screw (4000)	82.99	<b>GT-32111</b>
Rotor Feed Screw (7000)	69.99	<b>GT-10318</b>
Lead Drum Feed Screw (3000, 4000)	121.99	<b>GT-9918</b>

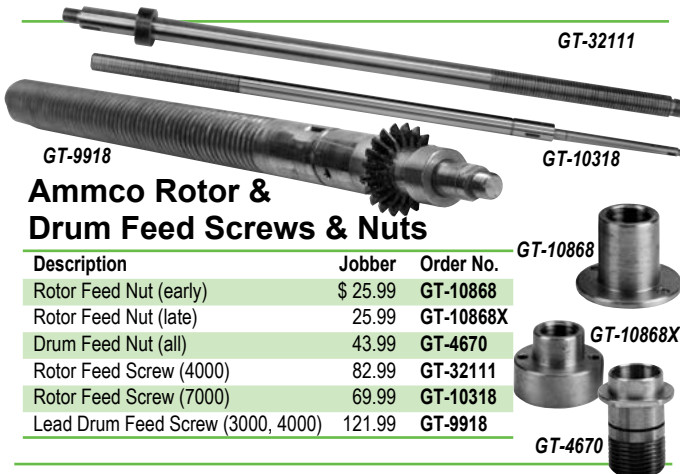

### Tooling Hold Down Pieces For Ammco

Description	Jobber	Order No.	Incl.
Stud Assembly	\$22.79	<b>GT-25900</b>	▼
6 1/2" Stud	4.99	<b>GT-25913</b>	x
Nut Assembly (must be used with 6 1/2" Stud)	17.99	<b>GT-11227</b>	x
5 1/2" Stud	5.99	<b>GT-3031</b>	
Washers (2)	8.99	<b>GT-3165</b>	



### Brass Wear Inserts For Ammco

Dia. x Lgth.	Jobber	Order No.
3/8" x 1/8"	\$1.99	<b>GT-3141</b>
1/4" x 1/4"	1.99	<b>GT-3142</b>
(most popular)		
1/4" x 1/8"	1.99	<b>GT-9836</b>



### Replacement Seals For Ammco

Application	Jobber	Order No.
Feed Screw	\$6.29	<b>3163</b>
Spindle	8.49	<b>3164</b>



### Replacement Screw for Twin Cutter Tool Bit Holders

- Square Head Screw
- Order No. **GT-9249** Jobber \$1.59



### Small Ammco Replacement Parts

Description	Jobber	Order No.
Locking Knob	\$2.29	<b>6854</b>
Cross Feed Shear Gear with C-Clip	5.29	<b>7996</b>



Buy 5 or more (mix & match 7996 or 6854) and SAVE 10% off jobber!

CYLINDER HEAD REBUILDING ASSEMBLY & SAFETY CLEANING SHORT BLOCK REBUILDING FLYWHEEL GRINDING CRANKSHAFT/ MISCELLANEOUS TOOLS & SUPPLIES BRAKE & TIRE CHANGING TOOLS MEASURING TOOLS V-TWIN & METRIC HARD PARTS

# full service ...fast



"We pride ourselves on getting orders to our customers quickly. We stock a wide variety of products so that we can get your order to you in 3 days or less."

- Brian, Receiving Department, 25 years of service

CYLINDER HEAD REBUILDING  
CLEANING, ASSEMBLY & SAFETY  
SHORT BLOCK REBUILDING  
CRANKSHAFT/ FLYWHEEL GRINDING  
MISCELLANEOUS TOOLS & SUPPLIES  
BRAKE & TIRE TUNING TOOLS  
MEASURING TOOLS  
V-TWIN & METRIC HARD PARTS

Screw Feed Boot # 3086

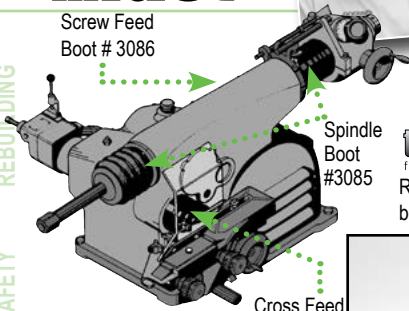

Spindle Boot #3085

Cross Feed Boot #3087

## Replacement Boot Packs

- Keep extra boots on hand for routine maintenance or emergency replacement
- Fits Ammco 3000, 4000, 4100, 7000, 7700



**GOODTOOL**  
Now exclusively from Goodson

**tech tips**  
from the techexperts™

Rubber is the standard boot material on most brake lathes



## Replacement Parts Pack

- Save time – never be caught without one of these essential brake lathe replacement parts again
- Save money – pack price is 10% lower than ordering all parts separately
- Save on shipping – purchasing these parts together costs less in shipping than ordering them individually at different times. You pay shipping and handling one time instead of several • All parts are also sold separately

Description	Jobber	Order No.	Incl.	
Neoprene Boot Pack	\$69.99	GT-BOOT-PK		
Rubber Boot Pack	64.99	RSB-BOOT-PK		
Neoprene Spindle Boot Kit	41.99	SBR-KIT		
Rubber Spindle Boot Kit	44.99	RSB-KIT		
Rubber Spindle Boot	21.99	RSB-3085	x	x
Neoprene Spindle Boot	16.99	3085	x	x
Screw Feed Dust Boot	12.79	3086	x	x
Cross Feed Dust Boot	12.79	3087	x	x
Boot Ring	23.29	23682	x	x
C-Clip	2.29	SBR-4435	x	x
Snap Ring	3.29	SBR-3159	x	x

Description	Jobber	Order No.	Incl.	
Replacement Parts Pack	\$59.99	GT-PARTS-PK		
Cross Feed Shear Gear	5.29	7996		2
Replacement Locking Knob	2.29	6854		2
Feed Seal	6.29	3163		1
Spindle Seal	8.49	3164		1
Neoprene Spindle Boot	16.99	3085		1
Screw Feed Dust Boot	12.79	3086		1
Cross Feed Dust Boot	12.79	3087		1

## Drive Pulleys & Belts for Ammco

- Fit Ammco 3000, 4000, 4100, 7000 & 7100
- Serpentine design runs quieter and increases arbor speed by 175RPMs
- Virtually eliminates vibration

Drive Pulley  
GT-3024



Driven Pulley  
GT-7784-1

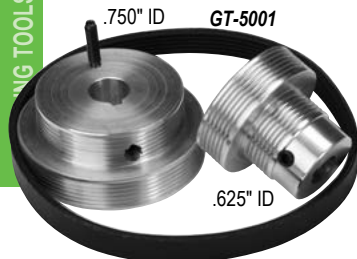

## New-Style (Serpentine)

Description	Jobber	Order No.
Pulley Set (Includes 20 1/4" belt & 2 pulleys)	\$124.99	GT-5001
20 1/4" Belt	19.99	GT-5002
19" Belt	19.99	GT-5003

**tech tips**  
from the techexperts™

Install the drive pulley with the pin toward the right angle drive. The two roll-pins drive against each other. A nylon sleeve prevents metal to metal contact.

## Original-Style (V-belt)

Description	Jobber	Order No.
Drive Pulley (Motor)	\$44.99	GT-3024
Driven Pulley (Arbor with drive pin)	79.99	GT-7784-1
25" Belt (replaces OE 3161)	8.99	GT-3161
24" Belt (replaces OE 10241)	8.99	GT-10241

See page 72 for more Flex-Hones®

Order 3 or more Flex-Hones® (mix & match) and save 10% off jobber

## Brake Rotor Flex-Hones®

- Provide a non-directional finish
- Use with a 3/8" variable speed drill at 600-1000 RPM
- Zirconium abrasive
- Use dry

Type	Grit	Jobber	Order No.
Fine	240	\$47.99	BRF-25F
Medium	120	47.99	BRF-25M
Coarse	60	47.99	BRF-25C



Buy any 2, Save 10% off jobber

## Brake Drum Swedge Cutting Tool

- Hard-to-find tool cuts wheel stud swedges to remove and replace pressed-in wheel studs
- Use with a drill press or mill
- Carbide tipped

Stud Size	Jobber	Order No.
7/16" (.4375")	\$89.99	ST-437
1/2" (.5000")	89.99	ST-500
9/16" (.5625")	89.99	ST-562



# Brake Lathe Replacement Parts

## Double Duty Cutting Tip Holders ... Like Getting Two Holders for the Price of One!



### Double Duty Brake Lathe Tip Holders

- Fits popular Ammco, Accu-Turn, FMC and Hoffman brake lathes
- Round holder on one end; triangular holder on the other
- Simply swap ends depending on the job you're performing
- Each holder includes one RT-312T Titanium Cutting Tip (triangular tip sold separately)
- Complete kits include one of each holder and a sample pack of tips (6 round, 4 triangle)

Application	Jobber	Order No.	Incl.
Ammco, All-Tool, Hoffman, Performance	\$87.99	DTAM-SET	▼
FMC, Accu-Turn, Hoffman, Kwik-Way, VanNorman	87.99	DTFM-SET	▼
Application	Size		
Ammco, Hoffman,	3/8" x 3/8" x 1 1/16"	Left 26.99 DTAM-312L	x
Performance, All-Tool		Right 26.99 DTAM-312R	x
FMC, Accu-Turn	3/8" x 3/8" x 2 3/4"	Left 26.99 DTFM-312L	x
Hoffman 400, Kwik-Way, VanNorman		Right 26.99 DTFM-312R	x

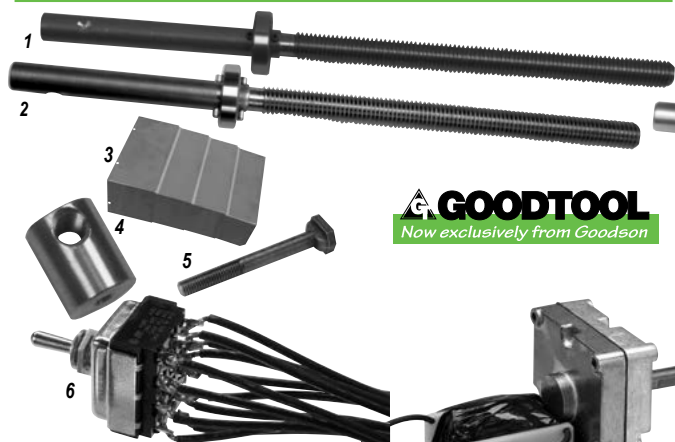

### Assorted Accu-Turn Replacement Parts

Description	Jobber	Order No.
1 Rotor Feed Screw Assembly (1/2" 20TPI)	\$ 46.99	GT-433156
2 Drum Feed Screw Assembly (1/2" 13TPI)	45.99	GT-433157
3 Telescoping Way Assembly (fits all except 8989)	189.99	GT-433735
4 Rotor Feed Nut	32.99	GT-433647
5 T-Bolt	13.99	GT-433633
Drum Feed Nut (not shown)	29.99	GT-433646
6 Replacement Switch (12 Poles)	74.99	GT-3693

**GOODTOOL**  
Now exclusively from Goodson

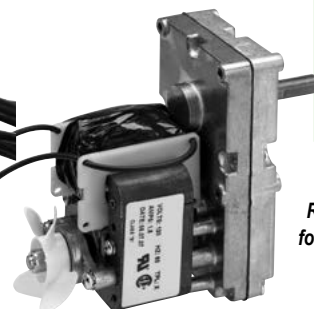

Replacement Motor for Ammco Lathes on page 113

### Replacement Feed Motor For Ammco Brake Lathes

- For 7700, 8920, 8910, 8911, 8989, 8922
- 1/60 HP • 6 RPM • 120V, 60Hz
- 1.5 Amps • Includes fan
- 2 year limited mfr. warranty
- Ships without blade attached to prevent damage
- Order No. **GT-3641** Jobber \$184.99

## Don't buy a new brake lathe ... expand your existing one to handle rotors up to 19 1/4"

### Lead Screw Bushing

- Easy installation
- Increases lathe capacity to 15"
- Fits Ammco 3000 and 4000 Brake Lathes
- Order No. **LSB-78529** Jobber \$29.49



### Cross Feed Extension Plate & Stud Assembly

- Fits Ammco models 3000 and 4000 Brake Lathes
- Increases capacity to 17 15/16"
- Order No. **GT-7936** Jobber \$184.99



### Expansion Assemblies for Ammco 4000 & 4100 Lathes

Description	Max. Dia.	Application	Jobber	Order No.	Incl
Lathe Expansion Set			\$249.99	GT-7935	▼
Lead Screw Bushing	15"	SUVs, Pick-ups	29.49	LSB-78529	x
Cross Feed Extension	17 15/16"	1-ton + Trucks	184.99	GT-7936	x
Lower Guide Bar (extends range by 1 1/2")	19 1/4" L		43.99	GT-70346	x

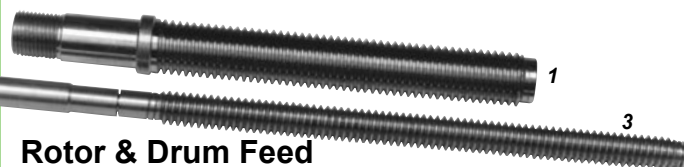

### Rotor & Drum Feed Screws & Nuts For FMC & Bean

Description	Jobber	Order No.
1 Rotor Feed Screw	\$39.99	GT-90071
2 Rotor Feed Nut	34.99	GT-90077
3 Drum Feed Screw	28.99	GT-90667
4 Drum Feed Nut	27.99	GT-1016845

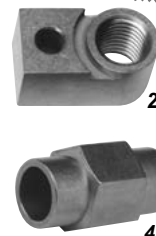

### Variable Speed Replacement Feed Motor For Accu-Turn 8944 & VN V-22 Brake Lathes

- 90V DC Permanent Magnet Gear Motor
- 1/2 HP • RPM F/L: 21
- Torque F/L: 50 in-lbs. • Ratio: 16:1
- Mounting: Face • 5/16" diameter shaft
- Sleeve bearings in motor and gearbox
- 2 year limited mfr. warranty
- Order No. **GT-6116** Jobber \$399.99



CYLINDER HEAD  
REBUILDING  
CLEANING,  
ASSEMBLY & SAFETY  
SHORT BLOCK  
REBUILDING  
CRANKSHAFT/  
FLYWHEEL GRINDING  
TOOLS & SUPPLIES  
MISCELLANEOUS  
BRAKE & TIRE  
CHANGING TOOLS  
MEASURING  
TOOLS  
V-TWIN & METRIC  
HARD PARTS

**Automotive Chuck  
Adaptor Kit (GT-70040)**

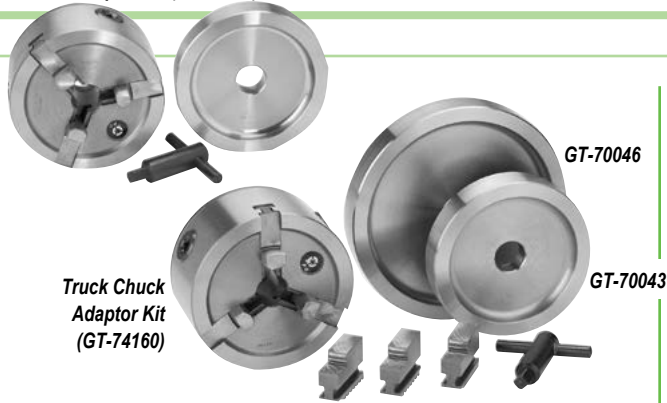

**Truck Chuck  
Adaptor Kit  
(GT-74160)**

**Quick Chuck Adaptor**  
**Replaces a Whole Wall of Adaptors,  
Centering Cones, Spacers, etc.**

- Eliminates mounting problems by self-centering
- Fits hubless rotors and drums, composite rotors and drums
- Fits most foreign and domestic rotors, drums and flywheels, including light trucks with a centering hole from 2 1/8" to 5 3/4" • Fits all popular 1" arbor brake lathes
- Kits include Adaptor with Jaws

Description	Range	Jobber	Order No.	Incl.
Automotive Chuck Adaptor Kit	2 1/8" to 3 3/4"	\$549.99	GT-70040	▼
Truck Chuck Adaptor Kit	2 1/8" to 5 3/4"	829.99	GT-74160	▼
Replacement Automotive Jaws	2 1/8" to 3 3/4"	134.99	GT-70045	
Large Jaw Set	3 3/4" to 5 3/4"	124.99	GT-70041	x
Standard Backing Plate, 5.2"OD		139.99	GT-70043	x x
Chuck Key		59.99	GT-70044	x x
Truck Plate (7 1/4" OD)		124.99	GT-70046	x
Toyota Plate (6 1/4" OD)		129.99	GT-70054	

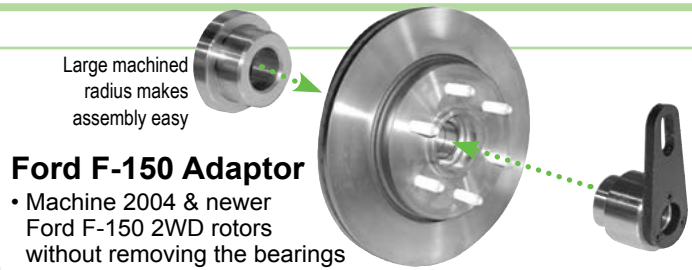

**Ford F-150 Adaptor**

- Machine 2004 & newer Ford F-150 2WD rotors without removing the bearings
- Fast, simple setup means less time spent on mounting the rotor on your lathe
- Two piece kit includes outboard centering drive adaptor and rear centering adaptor
- Approved for late model Ford F-150 two-wheel drive applications with pressed in bearings
- Order No. **FRA-5532** Jobber \$169.99

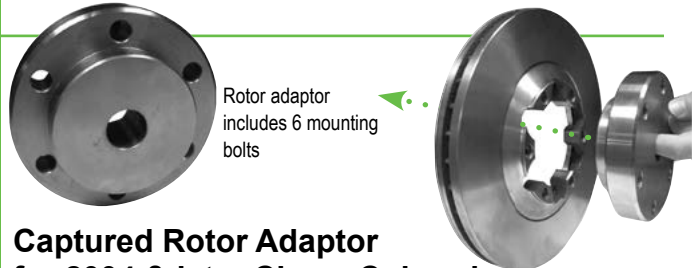

**Captured Rotor Adaptor  
for 2004 & later Chevy Colorado  
& GMC Canyon models**

- One-piece, self-centering rotor adaptor
- Compatible with all 1" arbor lathes
- Must mount with the adaptor and machined side of the rotor toward the lathe for twin cutter to align properly
- Order No. **CRA-2004** Jobber \$129.99

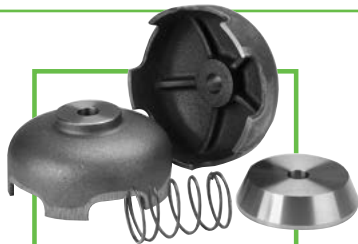

**GT-5062**

**Buy individual  
pieces or save  
by buying  
the sets**



**GT-5060**

**Truck Mounting Adaptor Sets  
For Brake Lathes With 1" Arbors**

Description	Jobber	Order No.	Incl.
Standard Truck Set	\$189.99	GT-5062	▼
Master Truck Set	279.99	GT-5060	▼
Centering Cones			
3.750" x 5.125"	59.99	GT-5053	1 1
4.500" x 5.500"	59.99	GT-5052	
5.000" x 6.125"	84.99	GT-5054	1
Bell Clamps			
6.500" OD	69.99	GT-5055	1 2
7.750" OD	79.99	GT-5056	1
Heavy-duty Spring	8.99	GT-5059	1 1



**Automotive Adaptors  
for 1" Arbor Brake Lathes**

Description	Jobber	Order No.
<b>Automotive Bell Clamps for 1" Arbors</b>		
OD Size		
3.625"	\$34.99	GT-9489
4.500"	35.99	GT-9490
5.750"	39.99	GT-3123
<b>Single-Tapered Centering Cones for 1" Arbors</b>		
Range		
1.250" - 1.750"	\$24.99	GT-3902
1.187" - 2.250"	35.99	GT-3903
1.703" - 2.750"	26.99	GT-3904
2.328" - 2.986"	29.99	GT-3108
2.650" - 3.224"	32.99	GT-3178
2.890" - 3.500"	31.99	GT-3107
3.421" - 4.031"	37.99	GT-3106
<b>Double-Tapered Centering Cones for 1" Arbors</b>		
Range		
1.322" - 1.670"	\$33.99	GT-9921
1.362" - 1.710"	36.99	GT-9922
1.711" - 2.073"	39.99	GT-9192
2.074" - 2.440"	41.99	GT-9193
2.441" - 2.897"	46.99	GT-9194
2.828" - 3.185"	79.99	GT-9195
3.203" - 3.560"	81.99	GT-9196

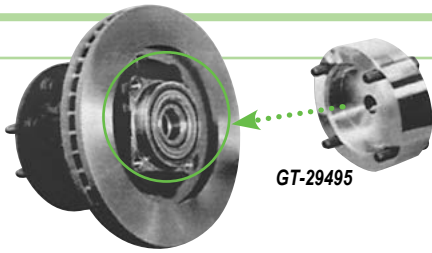

GT-29495

For GM 4x4 ('92 & later),  
Dodge Ram ('94 & later)  
Ford 1-ton ('98 & later)

### Late Model Rotor Adaptor

- Turn late model ¾ & 1-ton rotor assemblies without disassembly • Locates on the rear bearing flange • Mounts to any 1" arbor brake lathe
- One-piece adaptor with four bolts
- Order No. **GT-29495** Jobber \$99.99



### Brake Shoe Grinding Sleeves

ID	Lgth.	Grit	Application	Jobber	Order No.
3"	3"	100	Fits most models	\$ 2.09	<b>AS-1</b>
3"	5¼"	40	Fits most models	5.99	<b>AS-2</b>
3"	6"	40	Fits most models	4.99	<b>AS-3</b>
3"	6½"	40	Fits most models	6.99	<b>AS-4</b>
3"	7½"	40	Fits most models	6.99	<b>AS-6</b>
2⅞"	4½"	50	Fits Ammco 2007	4.99	<b>AS-7</b>
2⅞"	4½"	24	Fits Ammco	4.99	<b>AS-7C</b>
4"	6"	24	Shepard-Thompson	7.99	<b>AS-8</b>
4"	8¼"	40	Shepard-Thompson	11.99	<b>AS-10</b>
3"	4½"	50	Star	3.99	<b>AS-11</b>



### Mount/Demount Head for Coats

- Includes Hardware
- Fits Model Numbers: 5030, 5040, 5060, 5064, 6050, 6060, 7050, 7055, 7060, 7660, 7665
- Replaces OE 8180361
- Order No. **GT-18306** Jobber \$21.99



### Nylon Mount/Demount Head with Round Hole

- Hardware not included
- Fits **All Tool** (all models OE# G3008403; **Coats** (RC1, RC5, RC 10, RC15, RC20, Early 5060, 9010, 9024e, APX90 OE# 83008403) **Corghi** (all rim clamp models OE# 450310), **Hoffman** (all except 1550, 1620, 1625 OE# 8314813), **Hunter** (TCX Series (adaptor required), TCX5000 (requires upgrade & adaptor) OE# RP11-8314813), **Sice** M39, S40, S41, S43, S408MAXI, S435, S436, S436TOP OE# 8314813)
- Order No. **TC-45031** Jobber \$34.99



### Duck Head Inserts

- For FMC, Hoffman and Corghi • 10 pc. per pack
- Order No. **TC-24715** Jobber \$19.99



### Stainless Steel Mount/Demount Head

- Hardware included
- Fits **AccuTurn** (3602, 3602HP, 4260, 4560MR, 4602, 5602, 5602HP OE# 20024335); **Hoffman** (1520, 1656, 1620, 1625, 1625EM, 3300, 3300EM, OE# 24335), **John Bean** (EHP System IVE, IV, III, IIE OE# 24335); **Ranger** (980X, may also fit others); **Snap-On** (all models)
- Order No. **TC-26251** Jobber \$157.99



### Nylon Mount/Demount Head

- Hardware not included
- Fits **AccuTurn** (3602, 3602HP, 4260, 4560MR, 4602, 5602, 5602HP OE# 20024335); **Hoffman** (1520, 1565, 1620, 1625, 1625EM, 3300, 3300EM, OE# 24335), **John Bean** (EHP System IVE, IV, III, IIE OE# 24335); **Ranger** (980X, may also fit others); **Snap-On** (all models)
- Order No. **TC-20024** Jobber \$38.79



### Brake Lubes

These synthetic lubricants will make your brake jobs easier and your customers happier. **Silencer™ Brake Spray** is the backbone of this trio. Use silencer spray on your rotors and other contact surfaces. The revolutionary metalizing treatment is OE approved and is effective from -100°F to +2000°F. **Ceramlub-2800™** contains ceramic pressure solids and anti-corrosive agents. It is specially designed for use on caliper slides, rubber seals and O-Rings. **Pastelub™** is OE recommended and won't melt, rub or wash off brake parts. It contains no silicone or petroleum. **Pastelub™** is recommended for use on the back of brake pads.

Description	Jobber	Order No.
Silencer™ Brake Spray (Aerosol)	\$16.79	<b>BS-12*</b>
Ceramlub-2800™ Synthetic Lubricant (Purple)	16.79	<b>CBL-2800</b>
Pastelub™ Hi-Temp Lubricant (Gray)	16.79	<b>BPL-2400</b>

\*Hazardous Fees Apply When Shipped Air



 Buy a case of 12 (any combination), **SAVE 10% off jobber**

Ceramlub™ rated up to 2800°F

Pastelub™ rated from -300°F to 2400°F

CYLINDER HEAD REBUILDING  
CLEANING, ASSEMBLY & SAFETY  
SHORT BLOCK REBUILDING  
CRANKSHAFT/ FLYWHEEL GRINDING  
MISCELLANEOUS TOOLS & SUPPLIES  
BRAKE & TIRE CHANGING TOOLS  
MEASURING TOOLS  
V-TWIN & METRIC HARD PARTS



"The Mach-B division of Goodson offers many services such as ANSI compliant speed testing, balance testing, grinding wheel shaping, resizing and more. Find out more at Mach-B.com."  
- Jon, Goodson Production, 35 years of service

CYLINDER HEAD REBUILDING  
CLEANING, ASSEMBLY & SAFETY  
SHORT BLOCK REBUILDING  
CRANKSHAFT/ FLYWHEEL GRINDING  
MISCELLANEOUS TOOLS & SUPPLIES  
BRAKE & TIRE CHANGING TOOLS  
MEASURING TOOLS  
V-TWIN & METRIC HARD PARTS



## Metric Micrometer Set

- Complete set covers a range from 0 to 100mm in 25mm increments
- Graduations: 0.01mm • Carbide measuring faces
- Ratchet thimble and locking nut
- Includes 4 micrometers, 3 standards and storage case
- Order No. **MMS-100** Jobber \$179.99

## Premium Micrometers

- Precision ground carbide anvil parallel to within .00005"
- .0001" graduations
- Set includes wood storage case

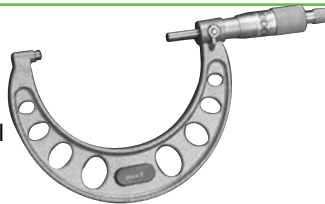

Description	Range	Jobber	Order No.	Incl.
<b>Economy Micrometer Set</b>	(wood storage case)	\$229.99	<b>EMS-06</b>	▼
<b>Individual Micrometers</b>	0"-1"	34.79	<b>EMIC-01</b>	x
	1"-2"	38.29	<b>EMIC-12</b>	x
Each Micrometer	2"-3"	42.79	<b>EMIC-23</b>	x
includes a Standard,	3"-4"	46.29	<b>EMIC-34</b>	x
Spanner Wrench & Case	4"-5"	54.99	<b>EMIC-45</b>	x
	5"-6"	57.99	<b>EMIC-56</b>	x

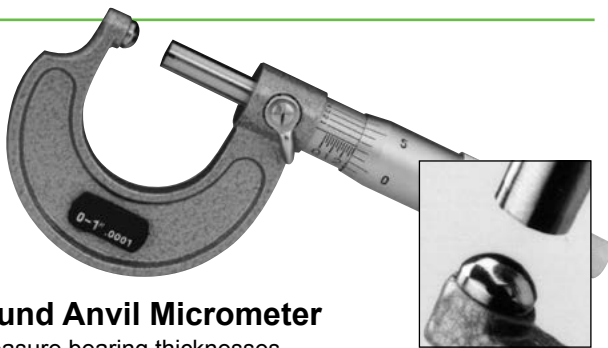

## Round Anvil Micrometer

- Measure bearing thicknesses
- Ratchet spindle • 0-1" range • Precise to .0001"
- Order No **MIC-01-B** Jobber \$99.99

## Checking Standards

- Use to set up dial indicators in special application gauging and to check micrometer accuracy
- Made of hardened, ground and lapped tool-steel
- Meet or exceed federal accuracy specifications



Length	Jobber	Order No.
1"	\$9.99	<b>MCS-1</b>
2"	9.99	<b>MCS-2</b>
3"	9.99	<b>MCS-3</b>

## Valve Seat Run-Out Gauge

- Measure run-out to .001"
- Hardened guide bushings and contact pilot
- Quick thumb screw set-up
- Jeweled bearing indicator reads to  $\pm 0.050$ " with .001" precision
- Range: 1.00" - 2.50"

Pilot Size	Jobber	Order No.
.375" / 9.53mm	\$149.99	<b>VSG-375</b>
.385" / 9.78mm	149.99	<b>VSG-385</b>



## Precision Valve Seat Run-Out Gauge

- Use with .375" Top Pilot
- Measure run-out to .0001" directly from the seat
- Locked to the pilot
- Dial indicator remains stationary while rotating contact pointer
- .800" - 2.500" dia. range
- Order No. **SCG-375** Jobber \$649.99



Open and close the padded jaws to accommodate most micrometers and dial bore gauges

Easy to reach knob adjusts the head angle

## Micrometer Stand

- Heavy cast iron construction
- Use to hold micrometers, standards or just about anything you need an extra hand for
- Swivel head and padded jaws won't damage expensive measuring tools
- Order No. **MIC-FIX** Jobber \$21.99



## Use the Micrometer Stand When Setting Your Dial Bore Gauge

Read more about it on our blog (<http://www.goodson.com/blog/2013/07/31/tips-and-tricks-for-setting-a-dial-bore-gauge/>). Scan the code at right to go to the blog.

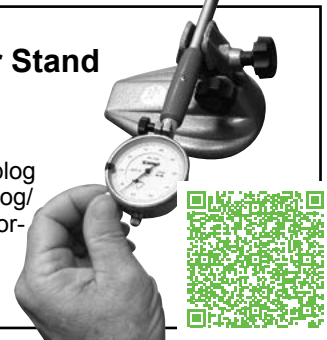

## Mitutoyo

### Small Hole Gauge Set

- See if rebuilding or replacement is needed by checking actual guide wear
- Check guide bosses for proper interference fit during replacement
- Check and maintain correct stem to guide ID clearance
- 4-piece set has combined range of .125"-.500" / 3.2-12.7mm
- Storage case included
- Order No. **SHG-5** Jobber \$134.99



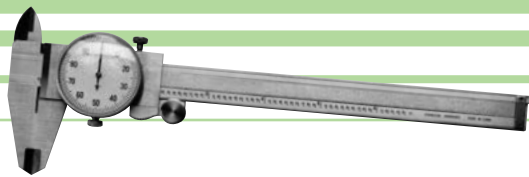

### 6" Direct Reading Dial Caliper

- Four way measurement - outside, inside, depth and step
- Hardened stainless steel with satin chrome finish
- Precision ground and lapped measuring surfaces
- Reads direct to .001" or with .100" graduations on beam
- Adjustable bezel with lock
- Thumb roll with lock
- 1 5/16" jaw length
- Large easy to read dial
- Covered rack • Deluxe fitted case
- Order No. **MDC-03** Jobber \$59.99

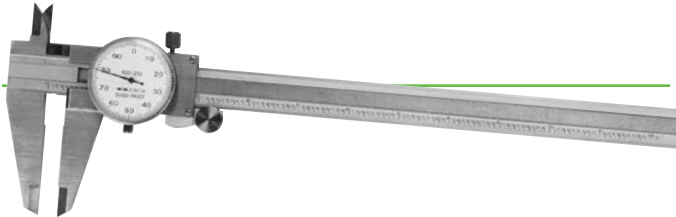

### 12" Direct Reading Dial Caliper

- .001" single revolution • Hardened measuring face
- Precision Ground • Micro-lapped for accuracy
- Adjusting slide for fine adjustment
- Take Inside, Outside and Depth measurements
- Satin Chrome finish with engraved graduations
- Clamp for repetitive readings
- Accurate to .001" per 6"
- Covered Rack • Deluxe fitted case
- Order No. **EDC-12** Jobber \$104.99

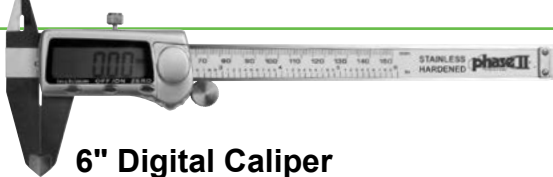

### 6" Digital Caliper

- Accuracy: .0008" under 4" length / .0012" over 4" length
- .0005" (.01mm) resolution
- Automatic floating zero
- Take Inside and Outside measurements
- Direct inch/metric Conversion
- Large, high-contrast LCD display
- On/Off Button • Deluxe fitted case

Description	Jobber	Order No.
Digital Caliper	\$54.99	<b>EEDC-06</b>
Replacement Battery	4.99	<b>EDC-06B</b>

### Dial Indicator Set with Locking Pliers and Flexible Arm

- Measure rotor runout or ball joint wear
- Flexible arm can be locked into almost any position
- Unit includes: flexible arm, dial indicator (0"-1"), curved jaw locking pliers and case

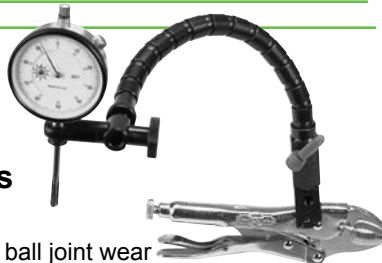

Description	Jobber	Order No.
Economy Disc Rotor & Ball Joint Gauge	\$136.49	<b>DIS-103</b>
Replacement Dial Indicator	27.99	<b>EDI-1</b>

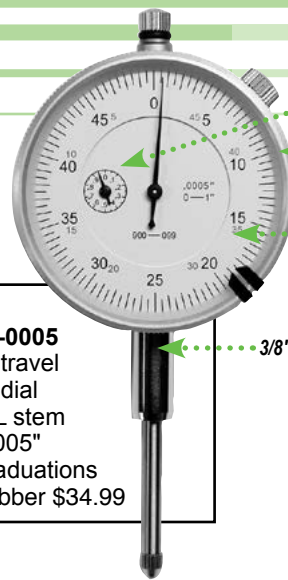

- EDI-0005**
- 1" travel
  - 2" dial
  - 1"L stem
  - .0005" graduations
  - Jobber \$34.99

Revolution Counter  
(included on most models)

Adjustable bezel  
for zero settings

Shatter resistant crystal

All Indicators  
have lug back

3/8" stem



- EDI-1**
- 1" travel • 2" dial
  - 1"L stem
  - .001" graduations
  - Jobber \$27.99



- MDI-110**
- .050" travel
  - 2" dial
  - 1"L stem
  - .0001" graduations
  - Jobber \$69.99



- MDI-12**
- .125" travel
  - 2" dial
  - 12"L stem
  - .001" graduations
  - Jobber \$369.99

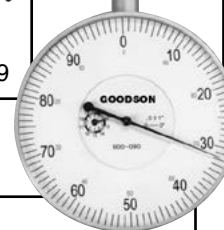

- MDI-2**
- 2" travel • 3" dial
  - 2"L stem
  - .001" graduations
  - Jobber \$59.99

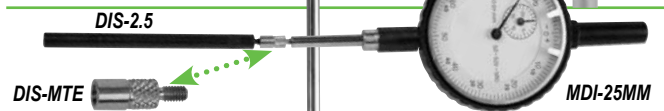

### Metric Dial Indicator & Accessories

Now you can use your metric dial indicator with standard spindle extensions! The Metric Dial Indicator Point Adaptor mounts to your dial indicator to convert its threads from 2.25mm to 2x48 TPI.

Description	Jobber	Order No.
Metric Dial Indicator	\$159.99	<b>MDI-25MM</b>
Metric Dial Indicator Point Adaptor	26.79	<b>DIS-MTE</b>
Spindle Extensions 1 1/2"	7.99	<b>DIS-1.5</b>
2 1/2"	10.49	<b>DIS-2.5</b>
3"	15.79	<b>DIS-3.0</b>

CYLINDER HEAD REBUILDING  
CLEANING, ASSEMBLY & SAFETY  
SHORT BLOCK REBUILDING  
CRANKSHAFT/ FLYWHEEL GRINDING  
MISCELLANEOUS TOOLS & SUPPLIES  
BRAKE & TIRE CHANGING TOOLS  
MEASURING TOOLS  
V-TWIN & METRIC HARD PARTS



### GOODSON Replacement Gauge For AG-300

- Reads in .001" increments
- Order No. **AG-GAUGE**
- Jobber \$89.99



### Sunnen® AG-Series Precision Gauge

- Dial reads directly in "tenths" (.0001")
- Checks rod journal bore for distortion
- Measures size instantly
- Wear-compensated gauge points for permanent accuracy
- Rugged construction – all moving parts are enclosed in the housing
- Includes Point Sets listed below (optional point sets available, call for information)
- Replacement Gauge swaps easily with the original

Description	Jobber	Order No.
.375" - 3.375" (9.5 - 85.7mm) Range Gauge	\$2881.73	<b>AG-300</b>
Standard Point Set (.720" - 1.530" Range)	47.36	<b>AG-210</b>
Medium Point Set (1.50" - 2.25" Range)	70.16	<b>AG-620</b>
Large Point Set (1.932" - 2.687" Range)	70.16	<b>AG-630</b>
Replacement Gauge (not OE Sunnen®) Reads in .001"	89.99	<b>AG-GAUGE</b>

*Point sets will NOT fit AG-gauges lower than Serial No. 4000*

### Rod Bolt Stretch Gauge

- Accurate to .001"
- Features a 1½" dial gauge
- Heavy-duty tension spring for repeatable accuracy
- For bolts from 1" to 2½" long



Description	Jobber	Order No.
Rod Bolt Stretch Gauge	\$79.99	<b>RBSG-3</b>
Optional Contact Point	8.49	<b>ERBG-3T</b>

**tech tips** Most engine rod failures aren't from the techxperts™ faulty parts, they're from improper installation.

When you're installing the rods, you need to check the rod bolt stretch by performing a series of torquing and loosening and recording the readings. Here's how:

1. Torque the bolts to 15 foot pounds and measure the stretch. Record the reading, then loosen the bolts.
2. Repeat at 15 foot pounds and record the reading.
3. Repeat, increasing to 30 foot pounds, record the reading.
4. Repeat, increasing to 60 foot pounds, record the reading.
5. Repeat at 60 foot pounds and record the reading.

Each time you loosen the bolts, measure to be sure that the rod bolts have returned to within .001" of the starting size. If you have a greater variation, get rid of the rod bolts and start with new ones.

When you're conducting final assembly, be sure you use the stretch specified by your rod manufacturer. Attach a rod bolt stretch gauge to the connecting rod bolt and zero it. Use an extra-long box wrench to tighten until the proper stretch is achieved.



### Setting Fixture

- Use with GA-2121, GA-2125, GR-2241 and GR-2245 Dial Bore Gauges (below)
- For 2" to 6" diameters
- Incorporates a tenth-reading micrometer head with precision carbide anvil
- Ring gauge checking standard included
- Precision standards in 1" increments
- Setting master has rugged, stress-relieved, cast iron base
- May be used without removing from protective case
- Order No. **CF-1126** Jobber \$1699.99

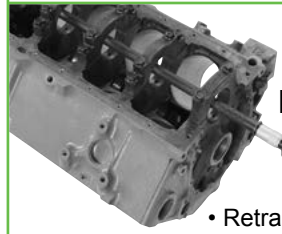

### Dial Bore Gauges with Retractable Centralizers

- Retractable self-centering gauging head mechanism
- Ideal for measuring bores typical of main bearing saddle and camshaft bearing bores
- Diameter range: 2" to 6" • 24" reach

Bore Gauge with Retractable Centralizers	Jobber	Order No.
.0001" graduations	\$1149.99	<b>GR-2241</b>
.0005" graduations	1149.99	<b>GR-2245</b>

### Dial Bore Gauges

- For cylinders, sleeves, large connecting rods and many other gauging jobs
- Diameter range: 2" to 6"
- 12" reach
- Self-aligning and self-centering
- Carbide contact points
- Insulated grip eliminates "drift"
- Includes molded case with extension points & wrenches



Dial Bore Gauge	Jobber	Order No.
.0001" graduations	\$969.99	<b>GA-2121</b>
.0005" graduations	969.99	<b>GA-2125</b>



### Split Ball Bore Gauge

- Dial gauge with large contact area
- Measures quickly & accurately to .0001" (.0025mm)
- Works in threaded or knurled guide IDs
- Range: .280"-.400" • Easy to change contacts
- Order No. **MVG-34** Jobber \$599.99



Mitutoyo

## Dial Bore Gauge Setting Fixture

- Fast, accurate setting from 2" to 6"
- Billet steel construction with a tool black finish
- Sets most popular bore gauges including Mitutoyo, Phase II, Fowler and Peacock • Will not fit Sunnen® Bore Gauges (see page 120 for Sunnen setting fixture)
- .001" increment micrometer • 3 setting standards (1", 2" & 3") included • Carrying case included
- Order No. **DBG-FIX** Jobber \$493.49

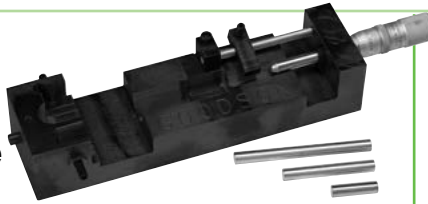

## Cylinder Dial Bore Gauge Sets

- Easy to read • Insulated grip
- Measure cylinders up to 9" deep
- Graduations: 0.0005" • Self-centering
- Chrome plated handle
- Includes extension holder and fitted case

Range	Jobber	Order No.
0.7" - 1.4" (18-35.6mm)	\$139.99	<b>FBG-7</b>
1.4" - 6.0" (35-150mm)	169.99	<b>FBG-146</b>



## Dial Bore Gauge Set

- Rugged bore gauge with protected dial
- Carbide tipped contact points
- .0001" (.001mm) graduations • Indication stability: .00008"
- Accuracy: .0002" • Shoe can be rotated for a fresh wear surface • Sets up with a standard micrometer (see page 118)

Range	Description	Jobber	Order No.
2.0"-6.0"	11 anvils and 4 spacers	\$539.99	<b>MMCB-06</b>
Replacement Spacers for anvils 2" & larger	.020"	9.79	<b>MMCB-06-020</b>
	.040"	9.79	<b>MMCB-06-040</b>
	.080"	9.79	<b>MMCB-06-080</b>
	.120"	9.79	<b>MMCB-06-120</b>
Replacement Lens		20.79	<b>MMCB-06LENS</b>
Replacement Dial Indicator		204.29	<b>MMCB-06IND</b>
Replacement Dial Cover		26.29	<b>MMCB-06COVER</b>

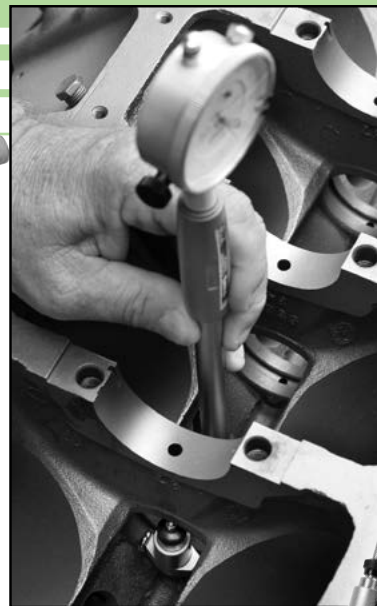

## 90° Dial Bore Gauges

- Measure cam bores, main bores and other hard-to-reach areas directly
- No passing through other bores to measure inboard journals • .100" travel in .0001" increments
- Metric has 3mm travel in .01mm resolution
- 3 spacers, 11 probes and case included

**Goodson**  
exclusive

Range	Graduations	Jobber	Order No.
2.0" - 6.0"	.0001" / .0025mm	\$349.99	<b>MCB-90</b>
50-160mm	.01mm	219.99	<b>DMBG-50160</b>



## Economy Bore Gauges

- Includes: .050" travel indicator, 3 spacers (.100", .050" and .020"), probes and case

Description	Range	Probes	Resolution	Jobber	Order No.
Standard US	2" - 6"	11	.0005"	\$139.99	<b>EBG-265</b>
Standard US	2" - 6"	11	.0001"	219.49	<b>EBG-261</b>
Metric	35 - 160mm	12	.01mm	174.99	<b>MCBG-160</b>
11 Pc. Replacement Spacer Set				29.99	<b>EBG-ANVILS</b>



## Internal Electronic Caliper

- Ideal for measuring, mating port runners and bowl measurements • Hardened contact surfaces
- Robust housing with large LCD display
- Range: 0.5" to 6.0" • Reading: .01"/.3mm/1/64ths
- Spring loaded locking nut
- Order No. **IEC-56** Jobber \$52.49

CYLINDER HEAD  
GRINDING  
ASSEMBLY & SAFETY  
REBUILDING  
SHORT BLOCK  
FLYWHEEL GRINDING  
CRANKSHAFT/  
MISCELLANEOUS  
BRAKE & TIRE  
MEASURING  
TOOLS  
V-TWIN & METRIC  
HARD PARTS

CYLINDER HEAD REBUILDING  
CLEANING, ASSEMBLY & SAFETY  
REBUILDING  
SHORT BLOCK REBUILDING  
CRANKSHAFT/ FLYWHEEL GRINDING  
MISCELLANEOUS TOOLS & SUPPLIES  
BRAKE & TIRE CHANGING TOOLS  
MEASURING TOOLS  
V-TWIN & METRIC HARD PARTS



Dial indicators sold separately

### Deck Bridge Tools

- Verify deck height without removing block from roll over fixture
- Flat anvil surface makes full contact
- Use Deck Bridge with either 1 or 2 dial indicators

Description	Jobber	Order No.
Deck Bridge (4½" span)	\$ 84.99	MDBS-2
Dial Indicator (12" OAL)	369.99	MDI-12
Dial Indicator Flat Anvil	24.99	MDI-12A
Economy Dial Indicator	27.99	EDI-1



### Valve Seat Height Gauge

- Confirm seat height to fire deck location
- Adjusts for all popular seat diameters
- Accurate to .001"
- Seat contact probe aligns on valve seat while gauge rides along the fire deck
- Pilot aligns in valve guide
- Adjustable to fit popular seat diameters from .750" to 3.00"

Includes Dial Indicator

Description	Fits Pilot	Jobber	Order No.
Valve Seat Height Gauge Kit	.375"	\$94.99	VSHG-375
Replacement Dial Indicator		27.99	EDI-1

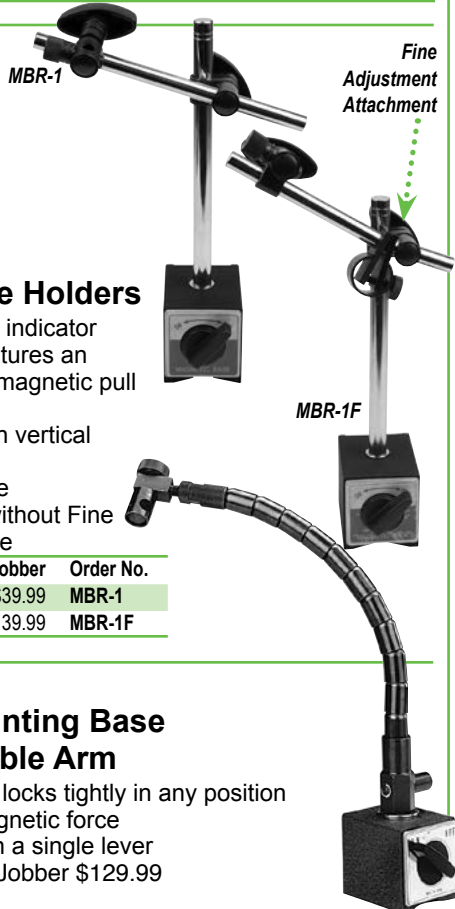

### Universal Magnetic Base Holders

- Fit any type of dial indicator
- Magnetic base features an on-off switch with magnetic pull of 90 pounds
- ¾" diameter 7" high vertical column
- 2" x 2½" x 2¼" base
- Available with or without Fine Adjustment Feature

Description	Jobber	Order No.
Universal Holder	\$39.99	MBR-1
With Fine Adjustment	39.99	MBR-1F

### Magnetic Mounting Base With 13" Flexible Arm

- Adjusts easily and locks tightly in any position
- 150 pounds of magnetic force
- Locks in place with a single lever
- Order No. **MFB-1** Jobber \$129.99

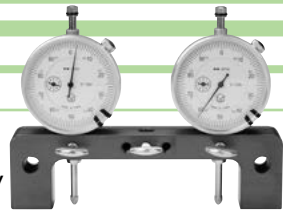

### Leak-Down Tester

- Apply air pressure in spark plug hole
- Compare supply psi to cylinder psi
- Includes 14mm & 18mm adaptors



Description	Jobber	Order No.
Leak Down Tester	\$99.99	LDT-50
Replacement Hose	25.29	LDT-HOSE
10mm Adaptor	12.79	LDT-10MM
12mm Adaptor	12.79	LDT-12MM

**tech tips** Listen to where air is leaking. Leakage at the carburetor indicates bad intake valves. Leakage at the tail pipe shows bad exhaust valves. Worn rings or cylinders are indicated by leakage at the dipstick while leakage at the radiator cap points to block problems.

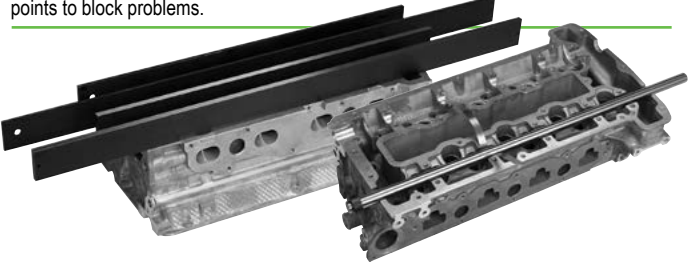

### Precision Straight Edges & Warp Gauge

Description	Jobber	Order No.
24" straightedge, 1 precision edge	\$119.99	DIS-24
36" straightedge, 1 precision edge	129.99	DIS-36
24" straightedge, 2 precision edges	159.99	DIS-20
35" straightedge, 2 precision edges	179.99	DIS-30
26" Round Warp Gauge ¾" dia. tool steel, 26" long	139.99	EWG-100



### 12" Feeler Gauges

- Use to measure piston-to-wall clearance when honing, to find ring end gap and to check cylinder heads with a straight-edge
- Also useful for shimming while straightening heads and for machine set-ups

	Jobber	Order No.	
<b>Complete Kit</b>	<b>\$39.99</b>	<b>FE-KIT</b>	<b>▼</b>
Thick .0015"	5.99	FE-0015	x
.0020"	5.99	FE-002	x
.0030"	5.99	FE-003	x
.0040"	5.99	FE-004	x
.0050"	5.99	FE-005	x
.0060"	5.99	FE-006	x
.0070"	5.99	FE-007	x
.0080"	5.99	FE-008	x
.0090"	5.99	FE-009	x
.0100"	5.99	FE-010	x
.0150"	5.99	FE-015	x
.0200"	5.99	FE-020	x

### 6 Pc. Telescoping Gauge Set

- Compress spring plunger and lock by twisting handle
- Insert into bore and release plunger – it will expand to fit
- Lock again and remove
- Measure with a micrometer
- Double plunger design for consistent measuring
- Long-lasting finish
- Size range: 5/16" - 6"
- Order No. **MTG-6** Jobber \$129.99

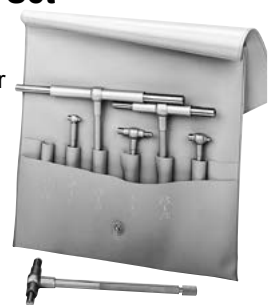

American Made



HVS-6MM HV-7MM HV-7MMOE HVS-421 HVS-531

## AV&V Hi-Temp Valve Seals for V-Twins

• Resist temperatures up to 50° higher than other seals

Size	Application	Guide OD	Stem Dia.	Qty.	Jobber	Order No.
6mm	V-Rod	8.5mm	6mm	20	\$19.99	HVS-6MM
7mm	Double Spring	.562"	7.0mm	20	29.99	HV-7MM
7mm	OE Replacement	.562"	7.0mm	20	29.99	HV-7MMOE
.421"	Evo / Twin Cam	.421"	.3125"	20	19.99	HVS-421
.531"	Evo / Twin Cam	.531"	.3125"	20	20.99	HVS-531

Buy 3 or more boxes of seals (mix & match) and take an extra 10% off jobber



HSS-420 HSS-530312 HSS-530341 HSS-562 HSS-625

## OE Style Valve Seals

Application	Guide OD	Stem Dia.	Qty.	Jobber	Order No.
Evo/Twin Cam	.421"	.312"	20	\$23.99	HSS-420
Evo/TC/Iron Head Sportster (Intake)	.530"	.312"	20	23.99	HSS-530312
Iron Head Sportster (Exhaust)	.530"	.341"	20	23.99	HSS-530341
Pan/Shovel Head (1948-79)	.562"	.375"	20	23.99	HSS-562
Shovel Head (1980-84)	.625"	.375"	20	23.99	HSS-625

## .423" Valve Seal Cutter

- Evo/Twin Cam
- Will shorten and chamfer the guide top, increasing seal-to-retainer clearance for higher lift camshafts
- Can also be used to modify .530" guides to .421" guides
- Guide OD: .421" • Pilot Size: .312"
- Use with HVS-421 seal (above)
- Order No. **VSC-420312**
- Jobber \$94.99



## Pan/Shovel Spring Seat Cutting Tool

- Easily convert Pan and early Shovel heads to late style Shovel heads
- Allows higher lift on Pan heads and early Shovel heads
- Included spacer stops the cutter at the correct height for uniform spring spacing
- Use with lower spring collars (HHC-4) or stock late-style lower spring collars (80-84)



Description	OD	ID	Jobber	Order No.
Spring Seat Cutting Tool	1.680"	0.750"	\$89.99	VSS-1680HD
.375" Spring Pad Pilot			27.99	VP-375

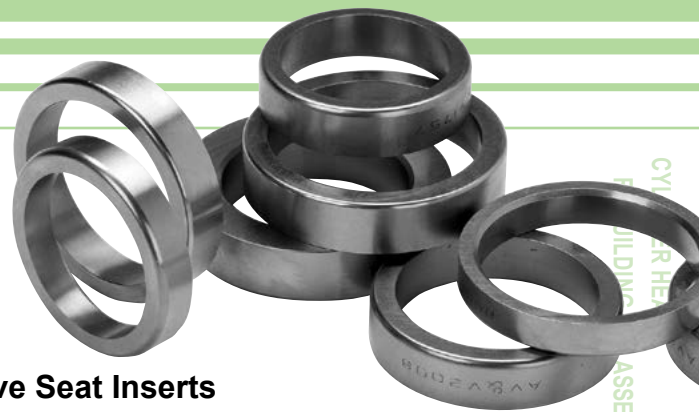

## Valve Seat Inserts

- For Harley
- Easy to machine
- Effectively dissipate heat for consistent valve sealing
- Hardness increases during engine break-in • Radiused for easy installation



### Replacement Valve Seats For Shovel Head 1200 & 1340

Application	OD	ID	Thickness	Jobber	Order No.
Exhaust	1.944"	1.575"	.400"	\$5.99	HVS-1944
Intake	2.135"	1.750"	.400"	5.99	HVS-2135

### Oversize Seats For Shovel, Evolution & Twin Cam – machining required

OD	ID	Thickness	Jobber	Order No.
1.630"	1.180"	.385"	\$5.99	HVS-1630
1.757"	1.410"	.430"	5.99	HVS-1757
1.882"	1.530"	.410"	5.99	HVS-1882
2.008"	1.610"	.440"	5.99	HVS-2008
2.040"	1.700"	.425"	5.99	HVS-2040
2.070"	1.610"	.460"	5.99	HVS-2070
2.132"	1.800"	.460"	5.99	HVS-2132
2.163"	1.750"	.455"	5.99	HVS-2163

### For Iron Head Sportster

Application	OD	ID	Thickness	Jobber	Order No.
Exhaust	1.757"	1.371"	.315"	\$5.99	HVS-1757S
Intake	2.068"	1.750"	.315"	5.99	HVS-2068

### Universal Repair Seat

OD	ID	Thickness	Jobber	Order No.
29mm	21mm	8.5mm	\$5.99	MVS-18
34mm	26mm	8.5mm	5.99	MVS-42
1.381"	.875"	.437"	5.99	MVS-46
1.505"	1.060"	.375"	5.99	MVS-50
1.630"	1.180"	.385"	5.99	MVS-54
1.692"	1.315"	.375"	5.99	MVS-58
1.820"	1.375"	.450"	5.99	HVS-1820
1.880"	1.435"	.410"	5.99	HVS-1880
1.945"	1.375"	.440"	5.99	HVS-1945
2.257"	1.550"	.500"	5.99	HVS-2257

### Nickel Chrome Valve Seats on Page 14

**tech tips** When installing seats preheat head to 400° and freeze the seat for easier installation. Press fit .006" to .008".  
from the TechExperts™

## Aluminum Seal Drivers

- A must-have tool for installing valve seats

Seal Size	Order No.
6.0mm	VSD-6MM
7.0mm	VSD-7MM
5/16"	VSD-312
11/32"	<b>NEW!</b> VSD-343
3/8"	VSD-375



## Valve Seal Drivers

- Color coded for easy size identification

Color	Size	Jobber	Order No.
Red	.420"	\$6.99	VSD-R
Black	.530"/.562"	6.99	VSD-B
White	.625"	6.99	VSD-W

Jobber \$23.99

... another  
satisfied  
customer

"We have been using Goodson for a while now and your commitment to quality products and to exemplary customer service makes doing our job so much easier!"

- Steve Vigen, Dirt Track Designs - Goodson Customer since 2007

CYLINDER HEAD REBUILDING  
CLEANING, ASSEMBLY & SAFETY  
SHORT BLOCK REBUILDING  
CRANKSHAFT/ FLYWHEEL GRINDING  
MISCELLANEOUS TOOLS & SUPPLIES  
BRAKE & TIRE CHANGING TOOLS  
MEASURING TOOLS  
V-TWIN & METRIC HARD PARTS



### Guide Driver for Reduced Diameter Top Valve Guides

The guide top fits into the groove between the driver and the bushing to center and drive the guide into place. Puts pressure on the step top of the guide, not the seal area. Required for installing HVG-5600S & HVG-5700S series guides (below).  
Order No. **VGD-315420** Jobber \$42.99

### Evolution, Twin Cam, Sportster With 5/16" Valves

- Use with .421" seals (**HVS-421** or **HVS-420**)
- Shorter seal area for high lift applications

OD	ID	Size	OAL	Intake	Exhaust
.5625"	.308"	Std.	2.100"	<b>HVG-5600S</b>	<b>HVG-5700S</b>
.5635"	.308"	+0.01"	2.100"	<b>HVG-5601S</b>	<b>HVG-5701S</b>

Jobber \$9.19 \$9.19

- Use with .531" seals (**HVS-531**)
- Shorter seal area for high lift applications

OD	ID	Size	OAL	Intake	Exhaust
.5625"	.308"	Std.	2.100"	<b>HVG-5600</b>	<b>HVG-5700</b>
.5635"	.308"	+0.01"	2.100"	<b>HVG-5601</b>	<b>HVG-5701</b>
.5645"	.308"	+0.02"	2.100"	<b>HVG-5602</b>	<b>HVG-5702</b>
.5655"	.308"	+0.03"	2.100"	<b>HVG-5603</b>	<b>HVG-5703</b>
.5665"	.308"	+0.04"	2.100"	<b>HVG-5604</b>	<b>HVG-5704</b>
.5875"	.308"	+0.25"	2.100"	<b>HVG-5625</b>	<b>HVG-5725</b>

Jobber \$9.19 \$9.19

- Use with .530" OE style seals (**HVS-530312**)
- Stock length for direct replacement

OD	ID	Size	OAL	Intake or Exhaust
.5625"	.308"	Std.	2.250"	<b>HVG-5500</b>
.5635"	.308"	+0.01"	2.250"	<b>HVG-5501</b>
.5645"	.308"	+0.02"	2.250"	<b>HVG-5502</b>
.5655"	.308"	+0.03"	2.250"	<b>HVG-5503</b>
.5665"	.308"	+0.04"	2.250"	<b>HVG-5504</b>
.5875"	.308"	+0.25"	2.250"	<b>HVG-5525</b>

Jobber \$9.19

### Twin Cam, Sportster & Buell With 7mm Valves

- Use with OE style Viton valve seals (**HV-7MM**)
- Profiled for optimum air flow

OD	ID	Size	OAL	Intake	Exhaust
.5625"	.273"	Std.	2.040"	<b>HVG-6600</b>	<b>HVG-6700</b>
.5635"	.273"	+0.01"	2.040"	<b>HVG-6601</b>	<b>HVG-6701</b>
.5645"	.273"	+0.02"	2.040"	<b>HVG-6602</b>	<b>HVG-6702</b>

Jobber \$9.19 \$9.19

### V-Rod

- Use with OE style valve seals (**HVS-6MM**)
- Profiled for optimum air flow

OD	ID	Size	OAL	Intake or Exhaust
.3955"	5.9mm	Std.	1.950"	<b>HVG-7000</b>
.3965"	5.9mm	+0.01"	1.950"	<b>HVG-7001</b>

Jobber \$9.19

### Manganese-Bronze Valve Guides

- Smooth finish to prevent damaging the head
- A self-centering tapered section for fast installation
- Chamfered on both sides
- Shorter valve seal area for high lift applications on every valve guides (except stock replacement models)
- Integral viton O-rings to prevent oil infiltration between the guide and the head
- Unfinished guide ID is ready to be precision-reamed or honed
- Manganese-bronze alloy allows tighter clearances for better heat dissipation, quieter running and longer engine life

### Shovel Head & Pan Heads

- Use with OE-style seals (**HSS-562**) • Stock length for direct replacement • 1200 Shovel Head

OD	ID	Size	OAL	Intake or Exhaust
.5660"	.375"	Std.	1.900"	<b>HVG-5300</b>
.5670"	.375"	+0.01"	1.900"	<b>HVG-5301</b>
.5680"	.375"	+0.02"	1.900"	<b>HVG-5302</b>
.5690"	.375"	+0.03"	1.900"	<b>HVG-5303</b>
.5700"	.375"	+0.04"	1.900"	<b>HVG-5304</b>
.5720"	.375"	+0.08"	1.900"	<b>HVG-5306</b>
.5740"	.375"	+0.08"	1.900"	<b>HVG-5308</b>
.5760"	.375"	+0.10"	1.900"	<b>HVG-5310</b>
.5910"	.375"	+0.25"	1.900"	<b>HVG-5325</b>

Jobber \$9.19

### Shovel Head

- Use with OE-style seals (**HSS-625**) • Stock length for direct replacement • 1340 Shovel Head (1979 to 1984)

OD	ID	Size	OAL	Intake or Exhaust
.6250"	.375"	Std.	1.900"	<b>HVG-5400</b>
.6260"	.375"	+0.01"	1.900"	<b>HVG-5401</b>
.6270"	.375"	+0.02"	1.900"	<b>HVG-5402</b>
.6280"	.375"	+0.03"	1.900"	<b>HVG-5403</b>
.6290"	.375"	+0.04"	1.900"	<b>HVG-5404</b>
.6310"	.375"	+0.06"	1.900"	<b>HVG-5406</b>
.6500"	.375"	+0.25"	1.900"	<b>HVG-5425</b>

Jobber \$9.19

### Iron Head (Cast Iron)

- Use with OE-style seals (**HSS-530312** or **HSS-530341**) • Shortened seal section allows .530" seal installation
- Fox XL 1957 to early 1983

OD	ID	Size	OAL	Intake	Exhaust
.5645"	.309"	Std.	1.750"	<b>HVG-5100C</b>	
.5655"	.309"	+0.01"	1.750"	<b>HVG-5101C</b>	
.5665"	.309"	+0.02"	1.750"	<b>HVG-5102C</b>	
.5675"	.309"	+0.03"	1.750"	<b>HVG-5103C</b>	
.5645"	.339"	Std.	1.750"		<b>HVG-5200C</b>
.5655"	.339"	+0.01"	1.750"		<b>HVG-5201C</b>
.5665"	.339"	+0.02"	1.750"		<b>HVG-5202C</b>
.5675"	.339"	+0.03"	1.750"		<b>HVG-5203C</b>

Jobber \$9.19 \$9.19

### Universal Repair Guides

- Manganese Bronze
- Ready to be custom machined

OD	ID	Size	OAL	Order No.
.7400"	7.0mm	7.0mm	2.700"	<b>UVBG-7MM</b>
.7400"	.3080"	.3130"	2.700"	<b>UVBG-308</b>
.7400"	.3750"	.3750"	2.700"	<b>UVBG-372</b>

Jobber \$9.19

# High Performance Valves

See page NP-4  
for the NEW  
Double Harley Head  
Mounting Plate



## tech tips

from the techxperts™  
Always check and confirm  
running clearances when  
installing new valves. See  
Goodson.com for information  
on Valve Tip Protrusion.

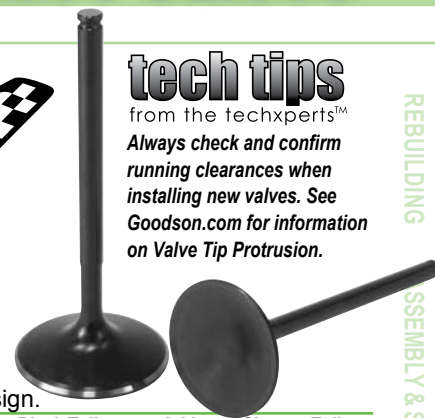

## Black Tulip® and Chrome Tulip Valves for Harley-Davidson® Engines

These superb valves feature the highest flow levels on the market. They are one piece forged from a racing grade stainless steel alloy and are available in hard black or chrome finish. Each valve has a bearing-quality hardened tip at the end of the stem to prevent premature wear with high-lift applications.

**NOTE:** AV&V 7mm Single groove keepers can be used on triple groove valves. Install keepers in the uppermost groove. This results in a stronger assembly than OE design.

Application	Type	Head Dia.	Back Angle	Overall Length	Stem Dia.	Tip Length	Groove	Jobber	Black Tulip®	Jobber	Chrome Tulip
Evo Big Twin & Twin Cam 5/16" Valves	Exhaust	1.585"	25°	4.505"	0.3106"	.2000"	Single	\$20.99	HBV-1585 (replaces obsolete HBV-1570)	—	—
	Exhaust	1.610"	25°	4.510"	0.3106"	.2000"	Single	20.99	HBV-1610D	—	—
	Exhaust	1.700"	25°	4.445"	0.3106"	.2000"	Single	—	—	\$31.99	HCV-1700
	Exhaust	1.700"	25°	4.535"	0.3106"	.2350"	Single	31.99	HBV-1700A	—	—
	Intake	1.900"	25°	4.440"	0.3108"	.2000"	Single	20.99	HBV-1900	—	—
	Intake	1.900"	25°	4.415"	0.3108"	.2000"	Single	21.99	HBV-1900S	—	—
	Intake	1.940"	25°	4.440"	0.3108"	.2000"	Single	20.99	HBV-1940	—	—
	Intake	1.990"	25°	4.440"	0.3108"	.2000"	Single	25.99	HBV-1990	—	—
	Intake	2.020"	25°	4.440"	0.3108"	.2350"	Single	23.99	HBV-2020A	—	—
	Intake	2.020"	25°	4.490"	0.3108"	.2000"	Single	—	—	23.99	HCV-2020
For Merch Heads (NEW)	Intake	2.060"	—	4.440"	0.3108"	—	—	27.99	HBV-2060A	—	—
7mm Twin Cam, Sportster, Buell	Exhaust	1.575"	25°	4.560"	0.2755"	.0850"	Triple	\$20.99	HBV-1575-7TG	\$20.99	HCV-1575-7TG
	Exhaust	1.610"	25°	4.545"	0.2755"	.0850"	Triple	20.99	HBV-1610-7TG	20.99	HCV-1610-7TG
	Intake	1.810"	25°	4.455"	0.2757"	.0850"	Triple	20.99	HBV-1810-7TG	20.99	HCV-1810-7TG
	Intake	1.850"	24°	4.455"	0.2757"	.0850"	Triple	20.99	HBV-1850-7TG	20.99	HCV-1850-7TG
	Intake	1.900"	24°	4.445"	0.2757"	.0850"	Triple	20.99	HBV-1900-7TG	20.99	HCV-1900-7TG
Sportster 883 to 1200 Conversion	Exhaust	1.480"	25°	4.640"	0.3106"	.2000"	Single	\$20.99	HBV-1480*	—	—
	Exhaust	1.485"	23°	4.680"	0.2755"	.0850"	Triple	22.99	HBV-1485-7TG	—	—
	Intake	1.720"	22°	4.560"	0.3108"	.2000"	Single	20.99	HBV-1720*	—	—
Sportster 1200 and Buell XB9 / XB12	Exhaust	1.575"	25°	4.620"	0.2755"	.0850"	Triple	20.99	HBV-1576-7TG	—	—
	Exhaust	1.725"	23°	4.580"	0.2757"	.0850"	Triple	20.99	HBV-1725-7TG	—	—
	Intake	1.770"	23°	4.480"	0.3108"	.2000"	Single	27.99	HBV-1770	—	—
	Intake	1.810"	24°	4.480"	0.2757"	.0850"	Triple	23.99	HBV-1811-7TG	—	—
	Intake	1.851"	24°	4.520"	0.2757"	.0850"	Triple	23.99	HBV-1851-7TG	—	—
	Exhaust	1.580"	25°	4.575"	0.3106"	.2000"	Single	—	—	\$31.99	HCV-1580
S&S®, Screaming Eagle® & Ultima® Heads	Intake	1.812"	24°	4.485"	0.3108"	.2000"	Single	—	—	31.99	HCV-1813
	Exhaust	1.610"	25°	4.565"	0.3106"	.2000"	Single	\$27.99	HBV-1610S	—	—
	Exhaust	1.700"	25°	4.655"	0.3106"	.2000"	Single	23.99	HBV-1700U	—	—
	Intake	2.020"	25°	4.510"	0.3108"	.2000"	Single	27.99	HBV-2020S	—	—
SE® / JIMS® 120 cu. in. Heads	Intake	2.060"	24°	4.510"	0.3108"	.2000"	Single	—	—	\$27.99	HCV-2060LC
	Intake	2.100"	23°	4.590"	0.3108"	.2000"	Single	23.99	HBV-2100U	—	—
	Exhaust	1.650"	25°	4.515"	0.3106"	.2000"	Single	27.99	HBV-1650	—	—
Intake	2.100"	24°	4.475"	0.3108"	.2000"	Single	27.99	HBV-2100	—	—	
	Intake	2.150"	24°	4.480"	0.3108"	.2000"	Single	—	—	\$31.99	HCV-2150
	<b>Extreme Duty High Flow Replacement Valves (stock length and head diameter)</b>										
Sportster 833 (1986-2003)	Exhaust	1.355"	23°	4.635"	0.3106"	.2000"	Single	\$20.99	HEV-1355	—	—
Sportster 833 (1986-2003)	Intake	1.590"	23°	4.550"	0.3108"	.2000"	Single	20.99	HEV-1590	—	—
Sportster 900-1000	Exhaust	1.561"	20°	3.505"	0.3389"	.1550"	Single	20.99	HEV-3	—	—
Sportster 900	Intake	1.812"	20°	3.615"	0.3108"	.2000"	Single	20.99	HEV-4	—	—
Sportster 1000 (1970-1984)	Intake	1.940"	20°	3.615"	0.3108"	.2000"	Single	20.99	HEV-5	—	—
Sportster 1200 (1987-2003)	Exhaust	1.485"	25°	4.560"	0.3106"	.2000"	Single	20.99	HEV-1485	—	—
Sportster 1200 (1987-2003)	Intake	1.720"	23°	4.480"	0.3108"	.2000"	Single	21.99	HEV-1720	—	—
Sportster 1200 (1987-2003)	Exhaust	1.785"	—	4.480"	0.3108"	—	—	20.99	HEV-1785 (Oversize)	—	—
Pan Head (1948-1965)	Both	1.750"	25°	3.830"	0.3764"	.2000"	Single	20.99	HEV-7	—	—
Shovel Head (1966-1984)	Intake	1.955"	20°	3.875"	0.3770"	.2000"	Single	20.99	HEV-9	—	—
Shovel Head (1966-1984)	Exhaust	1.750"	25°	3.830"	0.3764"	.2000"	Single	20.99	HEV-7	—	—
Evo 1340 (1984 & up)	Exhaust	1.615"	25°	4.525"	0.3106"	.2000"	Single	20.99	HEV-10	—	—
Evo 1340 & Twin Cam (1984 & up)	Intake	1.845"	—	4.440"	0.3108"	.2000"	Single	20.99	HEV-11	—	—
Twin Cam (1999-2004)	Exhaust	1.570"	25°	4.525"	0.3106"	.2000"	Single	20.99	HEV-12	—	—

\*additional machining required

CYLINDER HEAD  
REBUILDING  
CLEANING,  
ASSEMBLY & SAFETY  
SHORT BLOCK  
REBUILDING  
FLYWHEEL GRINDING  
CRANKSHAFT/  
MISCELLANEOUS  
BRAKE & TIRE  
MEASURING  
TOOLS  
V-TWIN & METRIC  
HARD PARTS



"Our job is to take your order correctly, confirm that the products are in stock and then get the order to shipping right away so that it ships the same day."

- Melanie, Goodson Customer Service, 1 year of service

CYLINDER HEAD REBUILDING  
CLEANING, ASSEMBLY & SAFETY  
SHORT BLOCK REBUILDING  
CRANKSHAFT/ FLYWHEEL GRINDING  
MISCELLANEOUS TOOLS & SUPPLIES  
BRAKE & TIRE CHANGING TOOLS  
MEASURING TOOLS  
V-TWIN & METRIC HARD PARTS

### Valve Spring Kits for 5/16" Valves

- Made from ultra-clean high silicon/vanadium Kobe alloy wire
- 1.375" top retainers for better clearance inside rocker covers
- Available with chromoly (S) or titanium (T) retainers
- Complete kit includes 4 springs, retainers, keepers and lower collars

Max. Lift	Seat Pressure	Open Pressure	Coil Bind Height	OD	ID	Jobber	Spring Kit Order No.	Jobber	Spring Kit Order No.	Jobber	10° Keepers Order No.
.600"	155 lb. @ 1.885"	405 lb. @ 1.260"	1.080"	1.460"	0.790"	\$101.99	HVS-600S	\$174.99	HVS-600T	\$13.99	HVK-311A-4
.650"	185 lb. @ 1.860"	460 lb. @ 1.160"	1.080"	1.460"	0.790"	129.99	HVS-650S	204.99	HVS-650T	13.99	HVK-311A-4
.675"	185 lb. @ 1.860"	460 lb. @ 1.160"	1.080"	1.460"	0.790"	—	—	239.99	HVS-675T	13.99	HVK-311A-4

evolution twin cam sportster



pan head shovel head



### Valve Spring Kits for 3/8" Valves

- Made from ultra-clean high silicon/vanadium alloy wire
- 1.375" top retainers for better clearance inside rocker covers
- Lightweight Chromoly retainers
- Complete kit includes 4 springs, retainers and keepers

Max. Lift	Seat Pressure	Open Pressure	Coil Bind Height	OD	ID	Jobber	Spring Kit Order No.	Jobber	8° Keepers Order No.	Jobber	Springs (4) Order No.	
.470"	155 lb. @ 1.375"	300 lb. @ 0.980"	0.850"	1.640"	1.010"	\$109.99	HVS-470S	\$13.99	HVK-375-4	\$74.99	HVS-470-4	
.530"	155 lb. @ 1.455"	320 lb. @ 0.980"	0.980"	1.640"	0.970"	109.99	HVS-530S	13.99	HVK-375-4	74.99	HVS-530-4	
.590"	175 lb. @ 1.455"	350 lb. @ 0.980"	0.850"	1.625"	0.965"	109.99	HVS-590S	13.99	HVK-375-4	74.99	HVS-590-4	
Upper Retainers with 8° Angle - 4 per pack			All sizes use the same retainer								26.99	HVR-530
Lower Collar - 4 per pack			All sizes use the same lower collars								29.99	HHC-4

### tech tips

These Pan/Shovel Valve Springs are from the techxperts™ NOT bolt-in items. Always be sure to check the minimum spring spacing and keep a minimum of .060" before coil bind at full lift.

Early 1948 to 1980 heads must be machined to accept AV&V's late style lower collars

You may need to machine the spring seat with the Goodson spring seat cutter (VSS-1680HD) and/or use upper spring retainer kit (HVR-530) and/or machine the valve seats deeper to get the correct spacing.

Spring spacing on the late style Shovel (1980 to 1984) with a 1.630" stem protrusion is +/-1.375"

### 7mm Chromoly Single Groove Retainer & Keeper Kits

- Use with Single Groove Valves or Triple Groove and OE Beehive Springs • Oversized 7° keepers are designed to be stronger than OE keepers • 4 Pc. Set
- Order No. HVR-7MM-SG Jobber \$34.79



### Evo & Twin Cam Valve Spring Shims

- Three thicknesses to choose from
- 20 per package

Thick	ID	OD	Jobber	Order No.
.015"	0.60"	1.48"	\$9.99	HVS-5015
.030"	0.60"	1.48"	9.99	HVS-5030
.022"	1.01"	1.44"	9.99	HVS-6022*

\*Use HVS-6022 with HV-7MMOE seals



### Pan/Shovel Spring Seat Cutting Tool

- Convert Pan & early Shovels to late style Shovel easily to attain higher lift
- Spacer stops the cutter at the correct height for uniform spring spacing
- Use with lower spring collars (HHC-4) or stock late-style lower spring collars (1980-1984) • OD: 1.680" • ID: 0.750"

Description	Jobber	Order No.
Spring Seat Cutting Tool	\$89.99	VSS-1680HD
.375" Spring Pad Pilot	27.99	VP-375



new design

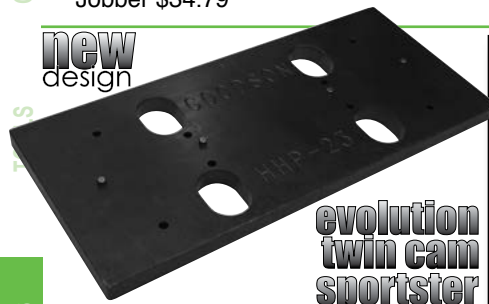

### Double Harley Head Plate

Mount two V-Twin heads at the same time. See page NP-4 for more information. Order No. HHP-23 Jobber \$749.99

evolution twin cam sportster

### V-Twin On-the-Engine Valve Spring Compressor

Replace broken valve springs, install high performance valve springs, remove and replace valve guide seals all without disassembling the bike – just remove the gas tank and get to work. Use on Sportster, Evolution, Twin-Cam and most aftermarket V-Twins. Kit includes valve spring compressor, adaptor for compressing beehive springs, valve seal driver/installer and head pressurizing hose. Order No. CF-HDIF Jobber \$159.99

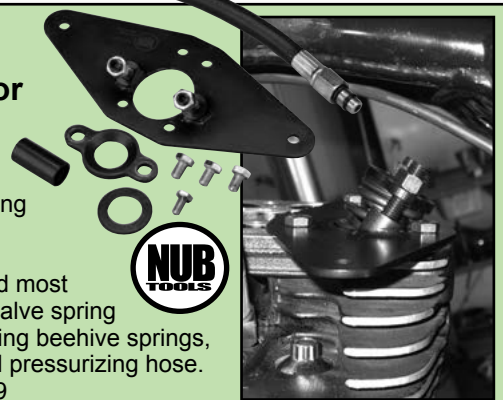



evolution  
twin cam  
sportster

### Beehive Valve Spring Kits for 5/16" Valves

- Micro shot peened and nitrided to resist the most severe environments
- Available with chromoly retainers
- CNC machined extreme duty 9° keepers
- Complete kit includes 4 springs, retainers, keepers and lower collars

Max. Lift	Seat Pressure	Open Pressure	Coil Bind Height	OD Lg/Sm	ID Lg/Sm	Jobber	Spring Kit Order No.	Jobber	9° Keepers Order No.
.600"	165 lb. @ 1.860"	384 lb. @ 1.250"	1.200"	1.445"/1.085"	1.000"/0.650"	\$99.99	HVS-6000S	\$13.99	HVK-311C-4
.650"	180 lb. @ 1.880"	385 lb. @ 1.120"	1.150"	1.500"/1.185"	1.055"/0.740"	101.99	HVS-6500S	13.99	HVK-311C-4

### tech tips

from the techxperts™

To achieve the best results, always use components from the same manufacturer. You'll be amazed at the difference!

### Beehive Valve Spring Kits for 7mm Valves

- Micro shot peened and nitrided to resist the most severe environments
- Available with chromoly retainers
- CNC machined extreme duty 9° keepers
- Complete kit includes 4 springs, retainers and keepers

Max. Lift	Seat Pressure	Open Pressure	Coil Bind Height	OD Lg/Sm	ID Lg/Sm	Jobber	Spring Kit Order No.	Jobber	9° Keepers Order No.
.600"	165 lb. @ 1.860"	384 lb. @ 1.250"	1.200"	1.445"/1.085"	1.000"/0.650"	\$92.99	HVS-6000-7SG	\$13.99	HVK-7MM5G-4
.650"	178 lb. @ 1.860"	385 lb. @ 1.200"	1.150"	1.500"/1.185"	1.055"/0.740"	109.99	HVS-6500-7SG	13.99	HVK-7MM5GC-4

Use HV-7MMOE valve seals with HVS-6000-7SG and HV-7MM with HVS-6500-7SG. Seals sold on page 123.



### Beehive Valve Spring Kits for 6mm Valves

- Ultra pure chrome silicon and nickel spring wire
- Extra processing to resist pressure loss and failure associated with aggressive cams in high compression engines
- Chromoly retainers • Use with stock lower collars
- Same spec as the Destroyer race version V-Rod
- Complete kit includes 8 springs, retainers and keepers (single groove or triple groove)

Max. Lift	Seat Pressure	Open Pressure	Coil Bind Height	OD	ID	Jobber	Single Groove Order No.	Jobber	Triple Groove Order No.
.580"	83 lb. @ 1.500"	280 lb. @ 0.900"	0.870"	1.100"	0.750"	\$239.99	HVS-7000SG	\$239.99	HVS-7000TG

Use with HVS-6MM valve seals. Seals sold on page 123.



### Compression Release Valves

- 2 per pack
- 10 x 1.0mm thread
- High temperature resistant knobs
- Shorter thread sections on HDCR-10S and HDCR-10L makes installation easier with less drilling required than OE-style

Application	Length	Thread	Jobber	Order No.
Evolution	1.080"	.425"L	\$44.99	HDCR-10S
Twin Cam	1.400"	.425"L	44.99	HDCR-10L
OE Replacement	1.250"	.475"L	44.99	HDCR-10D

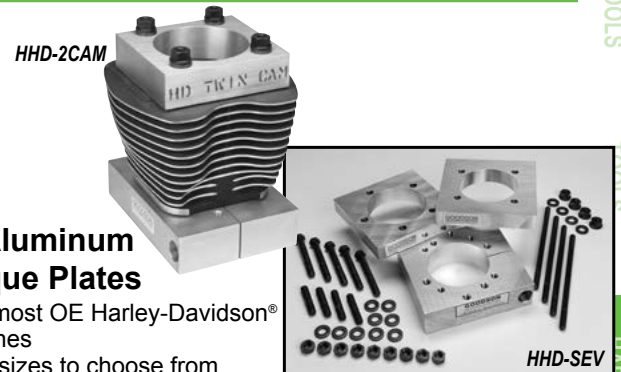

### T6 Aluminum Torque Plates

- For most OE Harley-Davidson® engines
- Two sizes to choose from
- Includes top and base plates and mounting hardware

Application	Jobber	Order No.
Evolution & Shovel	\$499.99	HHD-SEV
Twin Cam / V-Rod	499.99	HHD-2CAM

CYLINDER HEAD REBUILDING ASSEMBLY & SAFETY CLEANING, SHORT BLOCK REBUILDING CRANKSHAFT/ FLYWHEEL GRINDING TOOLS & SUPPLIES MISCELLANEOUS BRAKE & TIRE CHANGING TOOLS MEASURING HAND PARTS V-TWIN & METRIC

# RAPIDEX

A rapid-use index of product categories

## Cylinder Head Rebuilding

Pilots.....	1-3
Valve Seat Work.....	4-21
Valve Refacing.....	22-23
Reamers.....	24-25
Valve Guide Resizing.....	26-28
Valve Guide Replacement.....	29-34
Valve Seal Work.....	35
Valve Spring Work.....	36-42
Cylinder Head Resurfacing.....	43-46
Crack Detection & Repair.....	47-51
Porting & Polishing.....	57-60

## Cleaning, Assembly & Safety

Parts Storage & Organizers.....	61, 69
Wire Wheels & Brushes.....	62-63
Cleaning.....	63-68
Parts Baskets.....	68
Last Blast Paint & Metal Markers.....	70
Flex-Hones®.....	72

## Index Falls between pages 72 & 73

Coolants & Lubricants.....	73
----------------------------	----

## Short Block Rebuilding

Cylinder Boring & Honing.....	74-80
Boring Bar Tooling & Supplies.....	74-75
Honing Stones.....	76-80
Rod Honing.....	82-83
Rod & Piston Work.....	84-89
Lifter Bore Tooling.....	91
Camshaft Work.....	92-93

## Crankshaft/Flywheel Grinding

Crankshaft Grinding Wheels.....	94-95
Crankshaft Grinding & Polishing.....	96-100
Flywheel Grinding.....	101-103

## Miscellaneous Tools

Diamond Dresser Tools.....	104-105
Machine Replacement Parts.....	107-109
Technical Manuals & Videos.....	109

## Brake & Tire Changing Tools

Brake Tips & Holders.....	110-111
Brake Lathe Silencers.....	112
Brake Lathe Replacement Parts.....	113-115
Brake Lathe Mounting Adaptors.....	116-116

## Measuring Tools

Micrometers.....	118
Calipers & Dial Indicators.....	119
Dial Bore Gauges.....	120-121

## V-Twin & Metric Hard Parts

Seats & Seat Inserts.....	123
Valve Guides.....	124
Replacement Valves.....	125
Valve Springs.....	126-127

© Copyright 2016, Goodson Mfg. Co., Inc. All copy and illustrations are copyrighted. Absolutely no mechanical or electronic reproduction or use of any part is allowed without our prior written permission. Goodson reserves the right to correct printing errors. Prices are subject to change without notice.

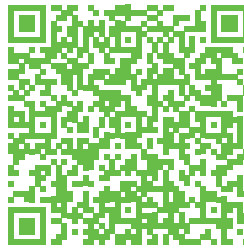

**Sign up to receive email from Goodson!**

Stay in touch with your favorite Shop Supply company by signing up to receive emails from us.

Get subscriber-only specials, technical updates, product updates and much more!

Scan the code above with your smart phone or visit <http://www.goodson.com/email-sign-up/>



## GOODSON Gear

Sport Goodson gear around the shop, at the track or just out and about!

Description	Color	Sizes	Jobber	Order No.
Pre-Shrunk Cotton T-Shirts	White	L, XL, XXL	\$15.99	RW-GTW-"size"
	Black	L, XL, XXL	15.99	RW-GTB-"size"
Caps	Black	adjustable	16.99	RW-GR-CAP
Polyester/Cotton Sweatshirts	Gray	L, XL, XXL	27.99	RW-SS-"size"
	Black	L, XL, XXL	27.99	RW-SB-"size"
Microfiber Jacket	Black	L, XL, XXL	64.99	RW-MFJ-"size"
Can Cooler	Green	n/a	1.99	RW-CC
Stocking Hat	Black	n/a	11.99	RW-SH

CYLINDER HEAD REBUILDING  
CLEANING, ASSEMBLY & SAFETY  
SHORT BLOCK REBUILDING  
CRANKSHAFT/FLYWHEEL GRINDING  
MISCELLANEOUS TOOLS & SUPPLIES  
BRAKE & TIRE CHANGING TOOLS  
MEASURING TOOLS  
V-TWIN & METRIC HARD PARTS

HF-1000KIT

# These Goodson Exclusives Deserve a Second Look!

## Hyper Finish Honing Station

Designed by Goodson to incorporate the features you requested in a bench-top honing station. See page 27 for full details. Order No. HF-1000KIT

## 12 Quart Pre-Lube Tank

The best engine pre-lube tank in the industry!  
12-Quart, corrosion-resistant aluminum tank with plenty of safety features. See page 89 for full details. Order No. EPL-120

## Powered Ring Filer with Integral Dressing Diamond

Eliminate time consuming ring filing ... set it once and cut multiple rings to the same specs! See page 87 for full details. Order No. PRF-812DW

## 600 Pound Analog Valve Spring Tester

This powerful analog spring tester features a 5" diameter Ashcroft pressure gauge that displays both pounds and kilograms. See page 41 for full details. Order No. VST-60G

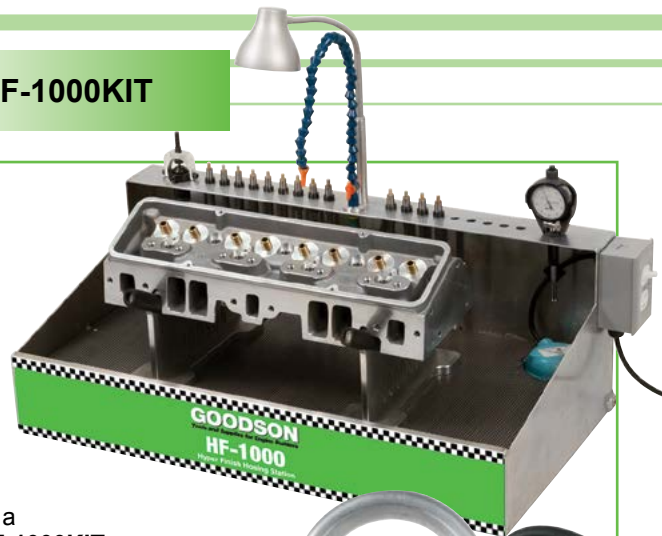

VST-60G

EPL-120



**American Made**

PRF-812DW

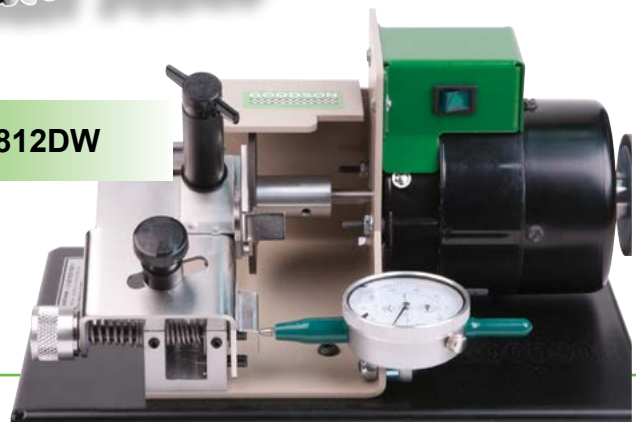

# GOODSON

Tools and Supplies for Engine Builders

156 Galewski Drive | Winona, MN 55987

Easy Toll-Free Ordering by Phone

**1-800-533-8010**

Toll-Free Fax 24-Hours a Day

**1-888-466-3909**

Order Online!

[www.goodson.com](http://www.goodson.com)

## Stay Connected With Goodson



[GoodsonToolsAndSupplies](https://www.facebook.com/GoodsonToolsAndSupplies)



[@GoodsonTools](https://twitter.com/GoodsonTools)



[@GoodsonDave](https://twitter.com/GoodsonDave)



[Goodson ShopSupplies](https://www.youtube.com/GoodsonShopSupplies)

Source Code

WPDF

Account Number

## GOODSON is Abrasives!

Whatever type of abrasive you need, you'll find it at Goodson

- Crankshaft Grinding Wheels & Polishing Belts
- Valve Seat Grinding Wheels
- Valve Refacer Wheels
- Cylinder Head Resurfacing Wheels, Segments & Belts
- Flywheel Grinding Stones
- Porting & Polishing Mounted Points, Flapwheels & Cartridge Rolls
- Much More!



# Index

<b>3-D Fast Cut™</b>	
3-D Fast Cut™ Starter Kits	4, 5
Ball Head Drive Adaptors	4, 5
Bounce Springs	4, 5
Bowl Profiler	10
Counterbore Cutters	6 - 9
Lift Clip	4, 10
Micro Ball Head Tooling	5, 7
Pilots	1 - 3, 5
Setting Micrometers	5
Tool Setting Fixture	4, 5
Universal Spring Pad Cutters	10, 40
Valve Seat Cutter Blades	6 - 9
Valve Seat Cutter Tool Holder	4, 5
Valve Seat Removal Tooling	5

## A

<b>Abrasive Belt Dresser</b>	100
<b>Abrasives</b>	
Aluminum Oxide Cloth Shop Rolls	58, 59
Belts	NP-4, 45, 98, 99
Bench Grinder Wheels	106
Cartridge Rolls	58
Cam Grinding Wheels	NP-3, 93
CBN Inserts	NP-6, 43
Chamfering Cones	40, 79
Crankshaft Grinding	NP-2, 94 - 95
Crankshaft Polishing Belts	NP-4, 98 - 100
Crocus Cloth	58
Cross Buffs®	58
Cylinder Head Resurfacing	NP-6, 44 - 46
Cylinder Honing	76-81
Diamond Honing	26
Diesel Super Abrasive Insert	43
Discs	58
Flapwheels	58
Flex-Hones®	28, 72, 80, 93, 114
Flywheel	NP-5, 102 - 103
Grinding Discs	58
Honing	72, 76 - 81
Hyper-Finish Diamond Honing	26
Mounted Points	60
PCD Inserts	NP-6, 43
Radiac	NP-2, NP-3, NP-5, NP-5, NP-6
Rod & Cap Grinding Wheels	NP-4, 83
Rod Honing / Pin Fitting	82, 83
Sleeves	59, 113
Valve Refacing	NP-3, 22 - 23
Valve Seat	NP-7, NP-8, 16 - 18

<b>Adjustable Coolant Hoses</b>	66
<b>Air Tools</b>	15, 19, 29, 30, 36, 37, 63, 64
<b>Align Honing</b>	81
<b>Aluminum Last Blast</b>	70
<b>Alumini-Chek</b>	50
<b>Ammco</b>	
Brake Lathe Arbor	113
Brake Lathe Cutting Tips	111
Honing Stone Sets	79
Replacement Parts	110, 113 - 115
<b>Aprons</b>	65
<b>Assembly Lubes</b>	55, 71
<b>AV&amp;V Brand Hard Parts</b>	123-127

## B

<b>Bags</b>	44, 66, 69
<b>Balance Shaft Eliminator Kits</b>	51
<b>Balancing Scales</b>	NP-4, 97
<b>Ball Head Seat Cutter Driver</b>	4, 5

<b>Ball Hones</b>	28, 72, 80, 93, 114
<b>Baskets</b>	65, 68
<b>Beehive Springs</b>	127
<b>Beeswax</b>	90
<b>Belt Dressers</b>	100
<b>Belts</b>	
Black & Decker Valve Refacer Belt	108
Crankshaft Polishing	98 - 100
Cylinder Head Resurfacing	45
Kwik-Way Valve Grinder Belts	109
Oil Pump Belts	82, 108
Rod Honing Belts (for Sunnen)	82, 108
Sioux Replacement Belts	107
Sunnen® Honing Machine Belts	108
<b>Bench Grinder Wheels</b>	106
<b>Bit Sharpener</b>	7
<b>Black &amp; Decker</b>	
Adaptor for Sioux Stones	19, 21
Belts for Valve Refacer	108
Replacement Collet	108
Stone Holders & Accessories	21
Valve Refacer Wheels	22
Valve Seat Stones	18
<b>Black Lights</b>	48, 49, 50
<b>Blood Friction Master®</b>	71
<b>Bluing Fluid</b>	11, 15
<b>Bore Gauges and Stands</b>	120, 121
<b>Boring Bar Cutters &amp; Accessories</b>	74, 75
<b>Bounce Springs</b>	NP-8, 4, 5, 20, 21
<b>Bowl Profiler Tooling &amp; Blades</b>	10
<b>Brake Flex-Hones®</b>	114
<b>Brake Lathe Arbors</b>	113
<b>Brake Lathe Cutting Tips</b>	111
<b>Brake Lathe Replacement Parts</b>	113 - 116
<b>Brake Lathe Silencer Bands</b>	112
<b>Brake Lathe Tip Holders</b>	110, 115
<b>Brake Lubes</b>	117
<b>Brass Shim Stock</b>	54
<b>Break-In Lubes</b>	71
<b>Bronze Liners &amp; Tooling</b>	32, 33
<b>Bronze Reaming Oil</b>	34, 73
<b>Bronze-Wall®, Bronze-Wall 2®</b>	31
<b>Brushes</b>	62, 63, 90, 93, 107, 109
<b>Burets and Stands</b>	42
<b>Burr Buster</b>	106
<b>Burrs, Carbide</b>	60
<b>Bushing Press Kit</b>	84

## C

<b>CamShield®</b>	71
<b>Calipers</b>	119
<b>Camshaft Work</b>	
Cam Bearing Tools	92, 93
Cam Bore Washing Brushes	62, 93
Cam Wheels	NP-3, 93
<b>Carbide</b>	
Brake Tips	111, 115
Burrs	60
Pilots	3
Reamers	25, 130
Resurfacing Tips	45
Rotary Files	60
Sizing Balls	31-33
Spot Facers / Top Cutters	34
<b>Cartridge Rolls</b>	58, 59
<b>CBN Cutter Inserts</b>	NP-6, 43
<b>CBN Flywheel Stones</b>	NP-5, 102
<b>CC-ing Equipment</b>	42

<b>Centering Cones, 60°</b>	32
<b>Ceramlub™</b>	117
<b>Chamfer Tools</b>	27, 33, 82
<b>Chamfering Cones</b>	40, 79
<b>Chevrolet</b>	
Conversion Plate	56
Smog Plugs	55
Starter Drill Jig	92
<b>Cleaning Supplies</b>	
Cleaning Media	65
Aprons	65
Baskets	65, 68
Brushes	32, 62, 63, 90, 93
De-foaming Agent	67
Detergents	67
Glass Beads	64
Gloves	64, 65, 68
Parts Tumbler Solution	65
Pro-Jet Spray Cleaning Powder	67
Roloc Bristle Discs	63
Safety Gear	58, 61, 65, 68
Scrapers	63, 92
Shop Towels	68, 71
Sludge Filter Bag	66
Soda Blast	67
Ultrasonic Detergents & Filters	67
<b>Clover Lapping Compound</b>	15
<b>Collets</b>	
Black & Decker	108
Dowel Puller	102
Expanding Pilots	2
<b>Concentricity Gauges</b>	11, 23
<b>Connecting Rod Heaters</b>	88
<b>Coolant Hoses</b>	66
<b>Coolants, Lubricants &amp; Oils</b>	
All-Purpose Grinding Coolant	73
Aluminum Machining Aid	58
Belt Resurfacer Coolant	45, 73
Bronze Reaming Oil	34, 73, 130
Cosmoline®	66
Crank & Cam Grinding Coolant	73, 95
Cutting and Tapping Fluid	11, 73
Cylinder Honing Oil	73, 79
Diamond Honing Oil	26, 73
Extreme Pressure Lube	71
First Lube and Blood Friction Master®	71
Flywheel Grinding Coolant	73, 103
Flywheel Grinder Table Lubricant	73
Gasket Maker / Thread Sealer	70
High Performance Resurfacing Spray	43, 73
High Performance Valve Grinding Aid	22, 73
Hylomar®	70
Knurlube	34, 73
Lap Oil	7, 58, 73, 75
Magnetic Crack Detection Oil	50
Micro Biostat	67
Minnesota Fast Freeze	11, 14, 29, 86
Multi-Duty Grinding Coolant	73
Porting & Polishing Machining Aid	58
Plate Lube	47
Press Fit Lubricant	30, 71, 86
Pumps	66
Rod Honing Oil	73, 82
Rust Inhibitor for Pressure Tester	51
Rust Proofing Oil	66
Rust Shield	44, 66, 69, 73
Seat Cutting Fluid	11, 73
Spray Assembly Lube	54, 71

# Index

## Coolants, Lubricants & Oils (cont.)

Surface Grinding Coolant .....	46, 73
Tap Oil .....	51, 73
Titanium Valve Grinding Aid.....	22, 73
Universal Gel Lube .....	40, 55
Valve Grinding Oil .....	22, 73
Valve Seat Machining Aid .....	11
Way Oil .....	73

Coolant Magnet .....	66
----------------------	----

Core Drills / Reamers .....	24
-----------------------------	----

Cosmoline® .....	66
------------------	----

Counterbore Cutters .....	6-10, 13, 14
---------------------------	--------------

Cross-Buffs® .....	58
--------------------	----

## Crack Detection and Repair

Additives.....	51, 52
Alumni-Chek .....	50
Applicators .....	48
Black Light Crack Detection Kit.....	49
Engine Seal Tabs .....	52
Fluid Weld® .....	52
Goodson Glow .....	50
Heat Tabs.....	52
Magnetic Crack Detection Kits.....	49
Magnetic Crack Detection Oil.....	50
Magnetic Powder .....	48
Magnetic Field Indicator .....	49
Parker Magnetic Crack Detection Unit.....	48, 49
Powder .....	48
Repair Kit .....	51
Seal-All™ .....	52
Small Parts Demagnetizer .....	49
Threaded Plugs, Irontite® .....	51
Ultra-Violet Light Inspection Kit .....	49, 50

## Crankshaft

Bearing Scraper .....	92
Crank Grinding Wheels .....	NP-2, 94, 95
Crank Welding Rods .....	100
Dial Indicator, Starrett .....	97, 119
Diamond Dresser Tools .....	93, 105
Display Inspection Stand.....	98
Elipitbur Tool .....	101
Grinding Coolant .....	NP-2, 73, 95
Hardness Tester .....	96
Harmonic Dampener Installer .....	101
Journal Radius Gauge .....	97
Peening Tool .....	96
Plastigage .....	96
Polishing Accessories .....	100
Polishing Belts .....	NP-4, 98, 99, 100
Polishers .....	100
Polisher Motor.....	100
Reluctor Ring Installation Tool .....	101
Steady Rest Shoes .....	97
Steel Stamps .....	100
Stroke Checker .....	96
Stroker Mimic™ .....	96
V-Blocks.....	96

Crocus Cloth.....	58
-------------------	----

Cummins Tooling .....	9, 24, 29, 30, 35
-----------------------	-------------------

Cutter Drivers & Adaptors .....	13
---------------------------------	----

Cutting & Tapping Fluid .....	11, 73
-------------------------------	--------

## Cylinder Block Work

Automotive Dowel Puller & Collets.....	102
Bore Washing Brushes .....	62, 93
Deck Bridge Combination Tool .....	123
Frost Plug Tools .....	91
Lifting Sling .....	92
Oil Gallery Brushes .....	62, 90

## Cylinder Block Work (cont.)

Oil Gallery Plugs & Tools .....	90
Pin Pal Puller .....	102

Cylinder Head CC-ing Equipment .....	42
--------------------------------------	----

## Cylinder Head Resurfacing

Belt Resurfacer Coolant .....	45, 73
CBN Cutter Inserts .....	NP-6, 43
Dressers .....	46
Grind Aid .....	44, 100
PCD Inserts for Aluminum .....	NP-6, 43
Rotary Broach Tool Bit .....	45
Segments .....	NP-6, 44
Surfacing Belts .....	45
Surfacing Wheels .....	NP-6, 46

## Cylinder Honing

Ammco Stones .....	79
Chamfering Cones and Mandrels .....	79
Goodson.....	76, 77
Hone Stop Collar .....	76
Honing Oil .....	73, 76, 79, 91
Keyway Honing Stones .....	78
Lisle® .....	78, 79
Nicasil .....	80
Plateau Honing.....	28, 78, 81
Portable Cylinder Hones .....	76
Small Diameter Honing Set .....	78
Stones .....	76 - 81
Sunnen® .....	76 - 78, 80 - 81

## D

D-Foam .....	67
--------------	----

Dampener Installer .....	101
--------------------------	-----

Deburring Tools .....	87, 106
-----------------------	---------

Deck Bridge Combination Tool .....	122
------------------------------------	-----

Deck Plug Kit .....	92
---------------------	----

Degree Wheel .....	92
--------------------	----

Demagnetizer.....	49
-------------------	----

Depth Gauge.....	102
------------------	-----

Detergents .....	67
------------------	----

Dial Indicators .....	97, 119
-----------------------	---------

Dial Bore Gauge Setting Fixtures.....	120, 121
---------------------------------------	----------

Dial Bore Gauges .....	120, 121
------------------------	----------

Dial Caliper Gauges .....	119
---------------------------	-----

Diamond Dresser Tools .....	NP-3, 83, 93, 104, 105
-----------------------------	------------------------

Diamond File Set.....	6
-----------------------	---

Diamond Flex-Hones® .....	72
---------------------------	----

Diamond Guide Hone Tools.....	26
-------------------------------	----

Diamond Honing Oil .....	26, 73
--------------------------	--------

Diamond Laps & Accessories .....	7, 75
----------------------------------	-------

Die Grinding Stones.....	59, 60
--------------------------	--------

Die Grinders .....	59
--------------------	----

## Diesel

Core Drills & Reamers.....	24
----------------------------	----

Guide Tooling .....	24, 26-28
---------------------	-----------

Heat Tabs .....	52
-----------------	----

Seat Installers .....	14
-----------------------	----

Spring Compressor .....	36
-------------------------	----

Super Abrasive .....	NP-6, 43
----------------------	----------

Valve Guides .....	24, 30
--------------------	--------

Valve Guide Tooling .....	24 - 33
---------------------------	---------

Valve Seals .....	24, 35
-------------------	--------

Valve Seat Cutter Blades .....	6 - 9
--------------------------------	-------

Dingleberry Hones .....	28, 72, 93
-------------------------	------------

Disposable Assembly Wipes .....	68, 71
---------------------------------	--------

DOHC Organizer Tray .....	61
---------------------------	----

DOHC Timing Chain Tensioner .....	75
-----------------------------------	----

Double Angle Valve Seat Wheels .....	18
--------------------------------------	----

Dowel Puller & Collets .....	102
------------------------------	-----

## Dressers

Abrasive Dresser.....	100
CBN Dressing Stick.....	102
Crankwheel Diamond Dressers.....	104, 105
Diamond Stone Dresser .....	83
Flywheel Stone Dressers .....	102
Hand-Held Dressing Sticks .....	96
Premium Diamond Dressers .....	104, 105
Resurfacer Grinding Wheel Dressers.....	46
Cutter Assemblies .....	46, 102
Star Dressers .....	46, 102
Valve Seat Wheel Dressing Stands .....	20

Drive Adaptors .....	4, 13
----------------------	-------

DVDs .....	109
------------	-----

Dykem® .....	11, 15
--------------	--------

## E

Economy Head Holder .....	57
---------------------------	----

Elipitbur Tool .....	101
----------------------	-----

Engine Pre-Lube Supplies .....	71, 89
--------------------------------	--------

Engine Balancing Supplies.....	97
--------------------------------	----

Engine Cart .....	61
-------------------	----

Engine Seal Tabs .....	52
------------------------	----

Epoxy, Porting.....	59
---------------------	----

Expanding Pilots .....	2
------------------------	---

Extreme Pressure Lube .....	71
-----------------------------	----

## F

False Guides.....	30, 124
-------------------	---------

Fast Freeze .....	11, 29, 86
-------------------	------------

Feeler Gauges .....	54, 122
---------------------	---------

File, Diamond.....	6
--------------------	---

Filter Bag .....	66
------------------	----

Filter Paper & Mats.....	80
--------------------------	----

First Lube .....	71
------------------	----

Flapwheels.....	58, 59
-----------------	--------

Flex-Hones® .....	28, 72, 80, 93, 114
-------------------	---------------------

Fluid Weld® .....	52
-------------------	----

## Flywheel Grinding

Bolt Adaptors .....	101
---------------------	-----

CBN Flywheel Stones & Dressing Stick .....	NP-5, 102
--------------------------------------------	-----------

Coolant.....	73, 103
--------------	---------

Dowel Puller & Collets.....	102
-----------------------------	-----

Depth Gauge .....	102
-------------------	-----

Dressers .....	102
----------------	-----

Grinding Stones .....	NP-5, 102, 103
-----------------------	----------------

Mounting Adaptor .....	NP-5, 103
------------------------	-----------

Flywheel Saver Shims .....	101
----------------------------	-----

Flywheel Step Gauge .....	102
---------------------------	-----

## Ford

Core Drills & Reamers.....	24
----------------------------	----

Flywheel Saver Shims .....	101
----------------------------	-----

Smog Plugs.....	55
-----------------	----

Torque Plates.....	75
--------------------	----

Valve Guides.....	30
-------------------	----

Frost Plug Tools .....	91
------------------------	----

## G

Gasket Maker.....	70
-------------------	----

Gas Porting Tools .....	86
-------------------------	----

Gauges.....	20, 23, 33, 40, 120 - 122
-------------	---------------------------

Gel Lube .....	40, 54
----------------	--------

## General Motors (GM)

Cam Bolt Locking Plate .....	92
------------------------------	----

Flywheel Saver Shims .....	101
----------------------------	-----

Vortec Adaptor Plate Set .....	53
--------------------------------	----

Vortec Seals.....	35
-------------------	----

Vortec Seal Cutter.....	34, 35
-------------------------	--------

Glass Beading Supplies.....	64
Glasses, Safety.....	58, 61, 68
Gloves	
Glass Bead.....	64
Heat & Flame Resistant.....	54, 68
Hot Tank Gloves.....	65
Nitrile.....	68
Parts Washing Gloves.....	68
Grind Aid.....	44, 100
Grinding Stones & Wheels (see Abrasives)	
Guide Installers (Drivers).....	NP-4, 29, 30
Guide Knurling	
Knurling Arbors.....	34
Knurlube.....	34, 73
OD Knurling Tool.....	34
Guide Liners.....	33
Guide Shoes.....	82
Guide Tooling, Diesel.....	24, 29
Guides.....	24, 30, 124
<b>H</b>	
Hardness Tester.....	96
Harley-Davidson® (see V-Twin)	
Harmonic Dampener Installer.....	101
Head Bolt Spot Facer.....	34, 56
Head Holders.....	42, 57
Head Saver Shims.....	55
Head Stands.....	42, 57
Head Straightening Fixture.....	54
Head-Bolt Hole Cleaners.....	51
Heat Tabs.....	52
Heavy Metal.....	97
Height Gauges.....	20, 40, 122
High Performance	
Cam Wheels.....	93
CC-ing Equipment.....	42
Gasket Maker & Thread Sealer.....	70
Resurfacing Spray.....	43, 73
Valve Grinding Aid.....	22, 73
Valve Seat Cutter Blades.....	6 - 9
Valve Spring Booster Shims.....	42
Valve Spring Compressors.....	36 - 38
Valve Spring Testers.....	41
Valve Train Checking Springs.....	40
Hi-Temp Last Blast.....	70
Hone Plates.....	75, 127
Hone Stop Assembly.....	76
Honing Oil.....	73, 76, 79, 91
Honing Stones	
Cylinder Honing.....	76 - 81
Pin Fitting.....	83
Rod Honing.....	82 - 83
Valve Guide.....	26, 28
Hoses.....	66, 122
Hot Tank Detergents.....	67
How-To Manuals & Videos.....	109
Hylomar® Gasket Maker & Solvent.....	70
Hyper Finish Diamond Guide Sizing.....	26
<b>I</b>	
ID Tags.....	69
IDL Core Drills & Reamers.....	24
IDL Valve Refacer Wheels.....	NP-5, 22
Indicators.....	20, 40, 41, 93, 97, 119, 122
Infinite Flow Cutting Tips (IFT).....	6
Instructional Manuals & Videos.....	109
Internal Calipers.....	121
Iron-tite.....	51, 52

<b>J</b>	
Jet Spray Cleaner.....	67
Jet Valve Eliminator Kit.....	51
Jet Washer Parts Baskets.....	68
<b>K</b>	
Keeper-Keeper.....	39, 65
Keeper Tools.....	38 - 39
Keyway Honing Stones.....	78
Knurling.....	34
KO Lee Type Pilots.....	2
KO Lee Valve Refacer Wheels.....	23
Kwik-Way	
Belts.....	45, 109
Boring Bar Cutters.....	74, 75
Core Drills & Reamers.....	24
Drive Adaptor.....	19, 21
Expanding Pilots.....	2
Heavy Duty Dressing Stand.....	NP-7, 20
Rebuild Kit for KW Holders.....	21, 109
Resurfacer Wheel Segments.....	44
Single-piece Resurfacer Wheels.....	46
Solid Tapered Pilots.....	1, 2
Stone Holders.....	21
Valve Refacer Wheels.....	22
Valve Seat Grinder Motor Units...NP-7 - NP-8, 19	
Valve Seat Stones.....	16, 18
<b>L</b>	
Lap, Diamond.....	7, 75
Lapping Compound.....	15
Lapping Oil.....	7, 58, 73, 75
Lapping Tools & Compound.....	15
Last Blast Paint.....	70
Layout Fluid.....	11, 15
Leak-Down Tester.....	122
Letter Stamps.....	69, 100
Levels & Vials.....	42, 43
Lifter Bore Tools.....	91
Lifting Sling.....	92
Lights	
Black Lights.....	48, 49, 50
Inspection Lights.....	106
LED Lights.....	106
Light Bulbs.....	48, 50
Work Light.....	113
Liners, Guide.....	33
Lisle® Honing Stone Sets.....	79
Litmus Paper.....	67
Lubricants	
Blood Friction Master®.....	71
Brake Lubes.....	117
Break-In Lube.....	71
Cam-Shield® Assembly Lube.....	71
Extreme Pressure Lube.....	71
First Lube.....	71
Flywheel Grinder Table Lubricant.....	73
Spray Assembly Lube.....	54, 71
Way Oil.....	73
<b>M</b>	
Magnetic Bolt Washer Removers.....	42
Magnetic Crack Detection.....	48 - 50
Magnetic VAD Holder.....	55
Magnetic Valve Spring Shim Removers.....	42
Mallory (heavy metal).....	97

<b>Mandrels</b>	
Align Hone.....	81
Butterfly Mandrels.....	58
Cross Buff / Flap Wheel Mandrel.....	58, 59
Diamond Sizing System.....	26
Honing.....	76
Rod Honing Mandrels.....	82, 83
Roll Mandrels.....	58, 59
Manual Ring Grinders.....	87
Manual Spring Compressors.....	37 - 39
Manual Vacuum Testers.....	47
Manual Valve Guide Drivers.....	NP-4, 29
Markers.....	69, 70
Measuring Tools	
Bore Gauges.....	120, 121
Calipers.....	119
Crankshaft Dial Indicator.....	97, 119
Dial Indicators.....	20, 40, 41, 93, 97, 119, 122
Feeler Gauges.....	54, 122
Flywheel Depth Gauge.....	102
Leak Down Tester.....	122
Micrometers.....	119
Rod Bolt Stretch Gauges.....	120
Setting Micrometers.....	5
Small Hole Gauge Set.....	33, 118
Straight Edges.....	54, 122
Stroke Checker.....	96
Telescoping Gauge Set.....	122
Valve Seat Run-Out Gauge.....	11, 118
Valve Seat Height Gauge.....	20, 122
Valve Stem Concentricity Gauge.....	23
Valve Stem Height Gauges.....	40
Warp Alignment Gauge.....	54, 122
Metal Markers.....	70
Micrometers.....	118
Micro Biostat.....	67
Minnesota Fast Freeze.....	11, 29, 86
Mitutoyo®	
Dial Bore Gauge.....	121
Hole Gauge Set.....	33
Split Ball Bore Gauge.....	33, 120
Mondello Seat Cutter Blades.....	6
Motors	
Brake Lathe.....	113, 115
Crankshaft Polisher.....	100
Seat Grinding.....	NP-7, NP-8, 19
Mounted Points.....	59, 60
<b>N</b>	
Neway	
Valve Seat Cutters.....	12
Easy Turn Wrench.....	13
Pilots.....	1 - 3
Replacement Cutter Blades and Screws.....	12
Solid Tapered Pilots.....	1
Nicasil Honing Stones.....	80
Number Stamps.....	69, 100
<b>O</b>	
O-Ring Wire.....	75
Oil Filter Tools.....	90
Oil Gallery Brushes.....	62, 90
Oil Gallery Tools.....	90
Oil Gallery Wax.....	90
Oil Pre-lube Tank.....	89
Oil Pump Belts.....	82, 108
Oil Pump Tools.....	90
Organizers.....	61

# Index

Oversize Bronze-Liners .....	33
Oversize Valve Guides .....	30, 124
Oversize Valve Seat Inserts .....	14, 123

## P

<b>Paint</b>	
Last Blast Spray Paint .....	70
Markers .....	70
<b>Parts Cleaning</b>	
Airless Blaster Media .....	65
Baskets .....	65, 68
Brushes .....	42, 62, 63, 90, 93
Detergent Powders .....	67
Glass Bead Tools & Supplies .....	64
Gloves .....	54, 64, 65, 68
Hydro-Air Guns .....	63
Keeper-Keeper .....	39, 65
Multi-Purpose Parts Degreaser .....	67
Parts Tumbler Solution .....	65
Pro-Jet Spray Cleaning Powder .....	67
Roloc Bristle Discs .....	63
Super Scraper™ .....	63
Tumbler Cleaning Media .....	65
Ultrasonic Detergents & Filters .....	67
Valve Stem Protectors .....	65
<b>Parts Storage &amp; Organizers</b>	
Baskets .....	68
DOHC Cylinder Head Tray .....	61
Engine Cart .....	61
Keeper-Keeper .....	39, 65
Organizer Trays .....	61
Parts Tags & Marker .....	69
Plastic Bags .....	44, 69, 70
Safety Pins .....	69
Shrink Wrap .....	68
<b>Parts Tumbler Media</b> .....	65
<b>Pastelub™ Hi-Temp Brake Lube</b> .....	117
<b>Peening Tool</b> .....	96
<b>Peterson</b>	
Boring Bar Cutters .....	74
Core Drills & Reamers .....	24
Crankshaft Grinding Wheels .....	95
Cylinder Head Resurfacing Belts .....	45
Resurfacer Wheel Segments .....	44
Single-piece Resurfacer Wheels .....	46
<b>pH Test Strips</b> .....	67
<b>Pilots</b>	
Expanding .....	2
Extended Length Top Solid-Tapered .....	3
Live .....	3
Micro .....	1, 2, 5
Serdi-Style .....	3
Solid-Tapered Steel .....	1
Split .....	2
Tapered Carbide .....	3
<b>Pin Bushing Press Kit</b> .....	84
<b>Piston Installing Tools</b>	
Deadblow Hammer .....	86
Electric Rod Heater .....	88
Gas-Fired Rod Heater .....	88
Piston Pin Installing Fixture .....	89
Ring Compressing Pliers .....	86
Rod Clamping Vise .....	89
<b>Piston Pin Removal Fixture</b> .....	85
<b>Piston Ring Filers</b> .....	87
<b>Plastigage</b> .....	96
<b>Plateau Hones</b> .....	28, 78, 81

## Plugs

Crack Repair .....	51
Deck Kit .....	92
Frost Plug Tools .....	91
Oil Gallery .....	90
Smog Plugs .....	55

## Pneumatic Tools

Air Hammer .....	29
Lapping Tool .....	15
Scraper .....	63
Valve Guide Drivers .....	29, 30
Valve Seat Grinder Driver .....	19
Valve Spring Compressors .....	36, 37

## Polishing Belts & Rouge

.....	98 - 100
-------	----------

## Portable Cylinder Hones

.....	76, 78
-------	--------

## Porting & Polishing

Abrasive Kits .....	59
Abrasive Rolls with Integral Mandrels .....	59
Aluminum Oxide Cloth Shop Rolls .....	58
Butterfly Mandrels .....	58
Crocus Cloth .....	58
Cross-Bufs® .....	58
Die Grinders .....	59
Epoxy .....	59
Flapwheels .....	58, 59
Mandrels .....	58, 59
Mounted Wheels .....	59, 60
Port Reshaping Kit .....	59
Porting Kits .....	59
Porting & Polishing Machining Aid .....	58
Replacement Abrasives and Mandrels .....	58
Rotary Files .....	60

## Powered Ring File

.....	87
-------	----

## Pre-Lube Tank

.....	89
-------	----

## Premium Tapered Reamers

.....	106
-------	-----

## Pre-Oiler

.....	89
-------	----

## Press Fit Lubricant

.....	30, 71, 86
-------	------------

## Press Kit, Tapered Pin

.....	84
-------	----

## Pressure Lube

.....	71
-------	----

## Pressure Tester Rust Inhibitor

.....	51
-------	----

## Pro Jet Spray Cleaning Powder

.....	67
-------	----

## Prussian Blue

.....	11, 15
-------	--------

## Pucks (VADs)

.....	55
-------	----

## Pullers

.....	14, 35, 56, 102
-------	-----------------

## Pumps

.....	27, 66
-------	--------

## Q

<b>Quick Mount Bar Set</b> .....	53, 108
----------------------------------	---------

## R

<b>Radial Wire Brushes</b> .....	63
----------------------------------	----

## Reamers

Bronze .....	25
Bronzwall .....	31
Carbide Valve Guide .....	25
Cobalt .....	25
Core .....	24
Diesel .....	24
High Speed Steel for Cast Iron .....	25
Piloted Core Reamers .....	24
Small Diameter .....	25
Tapered .....	106
Titanium Coated Cobalt .....	25

<b>Reaming Oil</b> .....	34, 73
--------------------------	--------

## Rebuilding Kits

Spring Compressor .....	39
Stone Holder .....	21, 109

<b>Reluctor Ring Installation Tool</b> .....	101
----------------------------------------------	-----

<b>Replacement Belt for B&amp;D Valve Refacer</b> .....	108
---------------------------------------------------------	-----

<b>Resurfacing Belts</b> .....	45
--------------------------------	----

<b>Resurfacing Wheel Segments</b> .....	NP-6, 44
-----------------------------------------	----------

<b>Resurfacing Wheels</b> .....	NP-6, 46
---------------------------------	----------

<b>Resurfacing Coolant</b> .....	45, 46, 73
----------------------------------	------------

<b>Resurfacing Dressers</b> .....	46
-----------------------------------	----

<b>Resurfacing Spray</b> .....	43, 73
--------------------------------	--------

<b>Ring Band Compressors</b> .....	86
------------------------------------	----

<b>Ring Expanders</b> .....	87
-----------------------------	----

<b>Ring Grinders</b> .....	87
----------------------------	----

<b>Ring Squaring Tool</b> .....	NP-4
---------------------------------	------

<b>Rocker Arm Tools</b> .....	56
-------------------------------	----

<b>Rockwell Hardness Tester</b> .....	96
---------------------------------------	----

<b>Rod and Cap Grinding Wheels</b> .....	NP-4, 83
------------------------------------------	----------

<b>Rod Balancing Stand</b> .....	97
----------------------------------	----

<b>Rod Bolt Boots</b> .....	89
-----------------------------	----

<b>Rod Bolt Installing Block</b> .....	89
----------------------------------------	----

<b>Rod Bolt Stretch Gauge</b> .....	120
-------------------------------------	-----

<b>Rod Clamping Vise</b> .....	89
--------------------------------	----

<b>Rod Heaters</b> .....	88
--------------------------	----

<b>Rod Hone Filter Mat</b> .....	80
----------------------------------	----

<b>Rod Honing</b> .....	82, 83
-------------------------	--------

<b>Rod Honing Oil</b> .....	73, 82, 91
-----------------------------	------------

<b>Roll Over Fixture</b> .....	53
--------------------------------	----

<b>Roloc Bristle Discs</b> .....	63
----------------------------------	----

<b>Rotary Broach Tool Bits</b> .....	45
--------------------------------------	----

<b>Rotary Files</b> .....	60
---------------------------	----

## Rottler

Boring Bar Cutters .....	74
--------------------------	----

Diamond Lap .....	75
-------------------	----

Sleeve Cutters .....	74
----------------------	----

Valve Refacer Wheels .....	NP-3, 23
----------------------------	----------

<b>Rust Protection</b> .....	44, 66, 69
------------------------------	------------

## S

<b>Safety Glasses</b> .....	58, 61, 68, 96
-----------------------------	----------------

<b>Safety Pins</b> .....	69
--------------------------	----

## Sanding (See Abrasives)

<b>Scales</b> .....	NP-4, 97
---------------------	----------

<b>Scrapers</b> .....	63, 92
-----------------------	--------

## Screws

Ball Head .....	4, 5
-----------------	------

Boring Bar .....	74
------------------	----

Carbide Cutter .....	4, 5, 10
----------------------	----------

Catspaw .....	74
---------------	----

Cross Buff Mandrel .....	58
--------------------------	----

Feed Screws .....	113, 114, 115
-------------------	---------------

Neway .....	12
-------------	----

<b>Scribe Tools</b> .....	11
---------------------------	----

<b>Seal-All™</b> .....	52
------------------------	----

<b>Seals</b> .....	24, 35, 123
--------------------	-------------

<b>Seal Cutters</b> .....	123
---------------------------	-----

<b>Seal Pullers</b> .....	35
---------------------------	----

<b>Seal Setters</b> .....	35, 123
---------------------------	---------

<b>Seat Cutters</b> .....	4 - 10, 12 - 14, 40
---------------------------	---------------------

<b>Seat Cutting Fluid</b> .....	11, 73
---------------------------------	--------

<b>Seat Drivers</b> .....	14
---------------------------	----

## Seat Grinding (see Valve Seat Grinding)

<b>Seat Removers</b> .....	5, 14
----------------------------	-------

<b>Segments</b> .....	NP-6, 44
-----------------------	----------

<b>Serdi Style Pilots</b> .....	3
---------------------------------	---

<b>Serdi-Style Bodies &amp; Drivers</b> .....	4, 13
-----------------------------------------------	-------

<b>Shim Stock</b> .....	54
-------------------------	----

<b>Shims, Flywheel Saver</b> .....	101
------------------------------------	-----

## Shot

Ceramic .....	65
---------------	----

Glass .....	64
-------------	----

Steel .....	65
-------------	----

<b>Shop Towels</b> .....	68, 71	<b>Sunnen®</b>	Valve Guides.....	124	
<b>Shrink Wrap</b> .....	69	Lifter Bore Hones .....	91	Valve Guide Reamers .....	25
<b>Silencer Brake Spray</b> .....	117	Main Bore Align Hone Mandrels .....	81	Valve Seals .....	123
<b>Silencers, Brake Lathe</b> .....	112	Mandrel Drivers .....	81	Valve Seat Cutter Blades .....	6 - 9
<b>Sioux™ Replacement Parts</b> .....	21, 65, 106, 107	Master Holder & Stone Supports .....	77	Valve Seat Inserts .....	123
<b>Sioux-Style</b>		Oil Pump Belts .....	82, 108	Valve Springs .....	126, 127
Drive Adaptor .....	19, 21	Plateau Honing Tools, Ultra-Finish .....	78	Valves .....	125
Drivers .....	NP-8, 19	Portable Cylinder Hones .....	76	<b>Vacuum Plates</b> .....	47, 107
Pilots .....	1 - 3	Press-Fit Lubricant .....	86	<b>Vacuum Testers</b> .....	47
Stone Holders .....	18, 21	Replacement Parts for CV-616 .....	108	<b>VADs</b> .....	55
Vacuum Plates .....	47, 107	Rod Chamfer Cutters .....	82	<b>Valve Adjustment Tools &amp; Discs</b> .....	55
Valve Refacer Wheels .....	23	Rod Honing Stones & Guide Shoes .....	82, 83	<b>Valve Grinding</b>	
Valve Seat Grinding Kit .....	NP-8	Silicon Compound .....	81	Adaptor for 1/2" Chucks .....	23
Valve Seat Stone Removers .....	20	Truing Sleeves .....	28, 83, 91	Black & Decker Valve Refacer Collets .....	108
Valve Seat Wheels .....	NP-8, 17 - 18	Valve Guide Hone Set .....	28	Bluing Fluid .....	11, 15
<b>Sizing Balls</b> .....	31 - 33	Valve Refacer Wheels .....	NP-3, 23	Diamond Dresser Tools .....	105
<b>Sling, Lifting</b> .....	92	<b>Super Scraper™</b> .....	63	Machine Parts .....	107 - 109
<b>Sludge Filter Bag (Sock)</b> .....	66	<b>Sure Shot® Sprayer</b> .....	66	Valve Grinding Aid .....	22, 73
<b>Smog Plugs</b> .....	53	<b>Surfacing</b>		Valve Grinding Oil .....	22, 73
<b>Snap-on</b>		Belts .....	45	Valve Refacer Wheels .....	22, 23
Replacement Brake Lathe Cutting Tips .....	111	CBN Inserts .....	NP-6, 43	Valve Stem Concentricity Gauge .....	23
Valve Refacer Wheels .....	23	Coolants .....	45, 46	<b>Valve Guide</b>	
Valve Seat Stones .....	18	PCD Inserts .....	NP-6, 43	Bronze-Liners .....	32, 33
<b>Spark Plug Thread Chaser</b> .....	106	Segments .....	NP-6, 44	Bronze-Wall® & Bronze-Wall 2® .....	31
<b>Spot Facers</b> .....	34, 56	Wheels .....	NP-6, 46	Brushes .....	28, 62
<b>Split Ball Bore Gauge</b> .....	33, 120	<b>Swedge Cutting Tool</b> .....	114	Core Drill / Reamer .....	24
<b>Spray Assembly Lube</b> .....	54, 71	<b>Switches</b> .....	107, 109, 113, 115	Diamond Hone Set .....	26
<b>Spring Compressors</b> .....	36 - 39, 126	<b>T</b>		Drivers .....	NP-4, 29, 30
<b>Spring Compressor Rebuild Kit</b> .....	39	<b>Tapered Reamers (For Tie Rods, Ball Joints)</b> .....	106	Flex-Hones® .....	28, 72
<b>Spring Pad Cutters</b> .....	10, 40	<b>Tap Cleaner</b> .....	51	Gauge Set .....	33, 122
<b>Spring Seat Cutting Tool</b> .....	34	<b>Tapered Pin Bushing Kit</b> .....	84	Guides .....	30, 124
<b>Spring Testers</b> .....	41	<b>Tapered Pin Bushing Kit</b> .....	84	Hone Set .....	26, 28
<b>Stamps, Steel</b> .....	69, 100	<b>Tapping Fluid</b> .....	51, 73	Knurling Tools .....	34
<b>Steady Rest Shoes</b> .....	97, 108	<b>Taps</b>		OD Chamfer Tool .....	27
<b>Steel Shim Stock</b> .....	54	Bronze-Wall .....	31	OD Knurling Tool .....	34
<b>Step Gauge</b> .....	102	Crack Repair .....	51	Plateau Hones .....	28, 81
<b>Stone Holders</b> .....	21	Head Bolt .....	51	Reamers .....	25
<b>Storage Bags</b> .....	44, 69, 70	<b>Telescoping Gauge Set</b> .....	123	Small Hole Gauge Set .....	33
<b>Storage Cart</b> .....	61	<b>Temperature Indicator Crayons</b> .....	54, 88	Spot Facer .....	34, 56
<b>Storm-Vulcan</b>		<b>Tensioner Stop Block</b> .....	75	Top Collars .....	27
Boring Bar Cutters .....	74	<b>Thin Wall Bronze Liners</b> .....	33	Top Cutters .....	34, 56
Crankshaft Grinding Wheels .....	NP-2, 95	<b>Thread Chaser</b> .....	106	Valve Guide Brushes .....	28, 62
Resurfacer Wheel Segments .....	44	<b>Timing Chain Tensioner</b> .....	75	<b>Valve Guides</b> .....	30, 124
Resurfacing Carbide Cutter Tips .....	45	<b>Titanium Coated Cutting Tips</b> .....	111	<b>Valve Lapping Tools &amp; Supplies</b> .....	15
<b>Straight Edges</b> .....	54, 122	<b>Tooling Stands</b> .....	21, 40	<b>Valve Refacing Wheels</b> .....	NP-3, 22, 23
<b>Stones</b>		<b>Top Cutters</b> .....	34, 56	<b>Valve Seal Drivers</b> .....	35, 123
Camshaft .....	NP-3, 93	<b>Torque-Angle Indicator</b> .....	56, 93	<b>Valve Seal Pullers</b> .....	35
Crankwheel .....	NP-2, 95	<b>Torque Plates</b> .....	75, 127	<b>Valve Seal Setter</b> .....	35, 123
Flywheel .....	NP-5, 102, 103	<b>Trays, Organizing</b> .....	61	<b>Valve Seals</b> .....	24, 35, 125
Honing .....	76 - 81	<b>Tumbling Media</b> .....	65	<b>Valve Seat</b>	
Porting & Polishing .....	60	<b>U</b>		Basic Valve Seat Grinding Kits .....	NP-7, NP-8
Refacing .....	NP-3, 22, 23	<b>Ultra-Finish Plateau Honing Tools</b> .....	28, 78, 81	Bounce Springs .....	20
Resurfacing .....	NP-6, 44, 46	<b>Ultrasonic Detergents &amp; Filters</b> .....	67	Cutter Blades .....	6 - 10, 12
Rod Honing .....	82, 83	<b>Universal Checking Standards</b> .....	118	Cutter Drivers .....	4, 5, 13
Valve Seat .....	16 - 18	<b>Universal Dressing Stand</b> .....	20	Cutting Fluid .....	11, 73
<b>Stroker Mimic™</b> .....	96	<b>Universal Gel Lube</b> .....	40, 54	Cutting System .....	4, 5, 10, 12
<b>Stud Extractor</b> .....	56	<b>Universal Head Holder</b> .....	57	Dressers .....	105
<b>Stud Pullers</b> .....	56	<b>Universal Spring Pad Cutter</b> .....	10, 40	Drivers .....	14
<b>Stud Stretchers</b> .....	43	<b>Utility Rolls</b> .....	58	Inserts .....	14, 123
<b>Sunnen®</b>		<b>V</b>		Layout Fluids .....	11, 15
Align Hone Mandrels .....	81	<b>V-Twin</b>		Machining Aid .....	11
Belts for Rod Honing Machines .....	82, 108	Double Head Plate .....	NP-4, 57, 126	Minnesota Fast Freeze .....	11, 14, 29, 86
Cap Grinding Wheels .....	83	Decking Jig .....	57	Neway Seat Cutting System .....	12, 13
Core Drills & Reamers .....	24	On-the-Engine Spring Compressor .....	39, 126	Nickel-Chrome Valve Seats .....	14
Cylinder Honing Stones .....	76 - 81	Organizer Tray .....	61	Removers .....	5, 14
Dial Bore Gauges .....	122	Torque Plates .....	127	Run-Out Gauges .....	11, 118
Guide Shoes .....	82, 83			Stone Holders .....	21
Honing Head for Rod Machines .....	82			<b>Valve &amp; Seat Scribe</b> .....	11

# Index

Valve Seat Wheels .....	16 - 18
Valve Seat Cutter Blades .....	6 - 9, 12
Valve Seat Counterbore Cutters .....	13, 14
Valve Seat Insert Driver .....	14
Valve Seat Wheels .....	16 - 18
<b>Valve Spring</b>	
Adaptors .....	37 - 39
Booster Shims .....	42
Calibrated Springs .....	41
Compressors .....	36 - 39, 126
Diesel Valve Spring Compressor .....	36
Inserts .....	42
Keeper Installation Tools .....	39
Manual Valve Spring Bench .....	37
Pneumatic Valve Spring Press .....	36
Rebuild Kit .....	39
Seat Cutters .....	10, 40
Spring & Retainer Kits .....	126 - 127
Testers .....	41
<b>Valve Spring Inserts</b> .....	42
<b>Valve Spring Shim Remover</b> .....	42
<b>Valve Stem</b>	
Concentricity Gauge .....	23
Dial Indicated Valve Stem Height Gauge .....	40
Protectors .....	65
<b>Valve Stem Oil Seals</b> .....	24, 35, 123
<b>Valves</b> .....	125
<b>Van Norman</b>	
Boring Bar Cutters & Parts .....	74, 75
Core Drills & Reamers .....	24
Crankshaft Grinding Wheels .....	95
Flywheel Cutter .....	101
Replacement Brake Lathe Cutting Tips .....	111
Resurfacer Segments .....	NP-6, 44
Single-piece Resurfacer Wheels .....	NP-6, 46
Valve Refacer Wheels .....	NP-3, 23
<b>Vertical Mill Roll-Over Fixture</b> .....	53
<b>Vials</b> .....	42, 43
<b>Vortec Tools</b> .....	53
<b>W</b>	
<b>Warp Gauge</b> .....	54, 122
<b>Way Oil</b> .....	73
<b>Wear Sleeves</b> .....	13
<b>Welding Rods</b> .....	100
<b>Wire Wheels &amp; Brushes</b> .....	62, 63
<b>Wrist Pin Bushing Press Kit</b> .....	84

# Powersports Index

<b>A</b>	
AV&V® Brand Hard Parts .....	123 - 127
<b>B</b>	
Beehive Valve Springs .....	127
Black Tulip® Valves .....	125
<b>C</b>	
Chrome Tulip Valves .....	125
Carbide Valve Guide Reamers .....	25
Compression Release Valves .....	127
Cylinder Hone .....	76
<b>D</b>	
Degree Wheel .....	92
<b>F</b>	
Flex-Hones® .....	72
<b>H</b>	
Hard Parts .....	122 - 127
Head Organizer Tray .....	61
Head Plate & Stand .....	57, 126
<b>K</b>	
Keyway Honing Stone Sets .....	78
<b>M</b>	
Manual Valve Spring Compressors .....	37 - 39
Micro Ball Head Tooling .....	5
Micro Valve Seat Wheels .....	17
<b>N</b>	
Neway Valve Seat Cutting System .....	12
<b>O</b>	
OE-Style Seals & Drivers .....	35, 123
On-The-Engine Spring Compressor .....	39, 126
<b>P</b>	
Pilots .....	1 - 3, 5
Porting Kits .....	59
<b>R</b>	
Reamers .....	25
<b>S</b>	
Small Diameter Portable Honing Set .....	78
Spring Seat Cutting Tool for Pan/Shovel .....	123
<b>T</b>	
Torque Plates .....	127
<b>V</b>	
Valve Guides .....	124
Valve Seal Cutter .....	123
Valve Seals .....	35, 123
Valve Seat Cutter Blades .....	6 - 9
Valve Seat Inserts .....	123
Valve Spring Compressors .....	36 - 39, 126
Valve Spring Shims .....	126
Valve Train Hard Parts .....	123 - 127
Valves .....	125

# Replacement Parts

## Black & Decker

Chuck Belt .....	108
Seat Stones .....	18
Stone Holders .....	21
Valve Refacer Collets .....	108

## Kwik-Way

Belts .....	109
Seat Stones .....	16, 18
Stone Holders .....	21
Stone Holder Rebuild Kits .....	21, 109
Valve Refacer Parts .....	109

## Sioux™

Belts .....	107
Driver Parts .....	107
Parts Tumbler Rebuild Parts .....	65, 106
Stone Holders .....	21
Wheel Dresser Parts .....	107
Vacuum Tester Gauge & Plates .....	107
Valve Grinder Parts .....	107
Valve Refacer Parts .....	107

## Sunnen®

CV-616 Honing Machine Belts & Gears .....	108
Rod Honing Machine Belts .....	82, 108
Valve Refacer Steady Rest Shoes .....	108

# Brake & Tire Changer Index

## A

Abrasive Sleeves.....	117
Accu-Turn Replacement Parts.....	115
Accu-Turn	
Mount / Demount Heads.....	117
Replacement Cutting Tips.....	111
All Tool Tips.....	111
Ammco Replacement Parts.....	113, 114, 115
Ammco Style Drum Silencers.....	112
Ammco Tips.....	111
Arbor Nuts.....	113
Arbors.....	113

## B

Backing Plates.....	116
Bean Tips.....	111
Bean Replacement Parts.....	115
Bear Tips.....	111
Bell Clamps.....	116
Bits.....	111
Brake Lubes.....	117
Brake Lathe Cutting Tips.....	111
Brake Lathe Tip Holders.....	110
Brass Wear Inserts.....	113
Brazed Carbide Cutting Tools.....	112

## C

Captured Rotor Adaptor.....	116
Carbide Brake Lathe Tips.....	111
Centering Cones.....	116
Ceramlub™.....	117
Chain Silencer.....	112
Clamp On Silencers.....	112
Cross Feed Dust Boots.....	114
Cross Feed Shear Gear.....	113, 115

## D

Double Duty Tip Holders.....	115
Double Tapered Centering Cones.....	116
Drive Pulleys & Belts.....	114
Drum Feed Screws & Nuts.....	113, 115
Duck Heads.....	117
Dust Boots.....	114

## F

Ford F-150 Mounting Adaptor.....	117
Feed Motor.....	115
Flex-Hones®.....	114
Flexible Arbor Spacers.....	113
FMC Replacement Parts.....	115
FMC Tips.....	111
Friction Silencers.....	112

## H

Hardspot Cutters.....	112
Hoffman Tips.....	111
Honed Edge Tips.....	111
Horvath Tips.....	111
Hunter Tips.....	111

## K

Kwik-Way Tips.....	111
--------------------	-----

## L

Late Model Rotor Adaptor.....	117
Lead Screw Bushing.....	115
Locking Knob.....	113

## M

Magnetic Strap Silencers.....	112
Mount / Demount Heads.....	117

## N

Neoprene Brake Lathe Silencer.....	112
Neoprene Spindle Boot.....	114

## P

Pastelub™.....	117
Performance Tips.....	111
Pro-Cut Tips.....	111

## Q

Quick Chuck Mounting Adaptor Set.....	116
---------------------------------------	-----

## R

Right Angle Drive Assembly.....	113
Rotor Adaptors.....	116
Rotor Feed Screws.....	113, 115
Rotor Silencers.....	112
Round Brake Lathe Tips.....	111
RTI Tips.....	111
Rubber Spindle Boots.....	114
Rubber Strap Silencers.....	112

## S

Screw Feed Dust Boots.....	114
Seals.....	113
Serpentine Drive Belts.....	114
Silencer Brake Spray.....	117
Silencer Bands.....	112
Snap-On Tips.....	111
Spacers.....	113
Spindle Boots.....	114
Springs.....	113, 116
Swedge Cutting Tool.....	114
Switches.....	113, 115

## T

Tip Holders.....	110
Tips.....	111
Tire Changer Mounting Heads.....	117
Titanium Coated Tips.....	111
Tooling Hold Down Pieces.....	113
Truck Adaptor Sets.....	116

## V

Van Norman & Rels Tips.....	111
Variable Speed Motor.....	115
VBG Tips.....	111

## W

Way Assembly.....	115
Wear Inserts.....	113

 **GOODTOOL**  
Now exclusively from Goodson

# Policies

## Pricing:

Prices are subject to change without notice. There is no minimum order. Orders are billed at the prices in effect at the time of shipping. Discounts are not available on Sunnen® products.

## Shipping:

Goodson ships orders the same day they are received. Orders received after hours, on weekends or holidays are shipped the next business day. You have several choices of shipping speed. Cost of shipping is based on total weight or package dimensions and the distance from our warehouse. Many changes have recently been implemented by shipping companies. Goodson is working with these companies to ensure you receive your orders promptly without additional cost.

▪ **STANDARD:** Unless otherwise requested, we ship items up to 150 lbs. and up to 130" in combined width, length and height by US Postal Service, UPS or FedEx services. Items over the weight or size limit must go by common carrier.

▪ **EXPRESS:** We can ship most items by air to arrive in your choice of 1, 2 or 3 days. Please note that Goodson is not responsible for weather related delays.

Upon receipt of your order, please inspect all cartons immediately for damaged or missing products before signing for the merchandise. Any packages received in a damaged condition should be rejected and/or noted at the time of receipt. The customer assumes all risk of lost or damaged products in transit and likewise, assumes responsibility for filing a claim with the carrier. Any damage must be reported within 5 days of receipt (delays in reporting damage will prevent the carrier from accepting responsibility for damage and you will then be held responsible for the merchandise). Goodson will assist you in any way we can to help with your claim to the carrier.

In the event that items are missing from your shipment, please contact Goodson within 3 business days. Contact Goodson at **1-800-533-8010**.

## Freight:

For orders shipped ground within the USA, you may deduct the freight charges on any **JOBBER** net invoice of **\$800** or more if you pay within 30 days. However, Glass Beads, Steel Shot, Tumbler Media, Machines, Equipment, Bulk Liquids and Crankwheels are not included (shipped F.O.B. Winona, MN). Hazardous Materials, Dangerous Goods and Dimensional Shipping fees may apply on certain items. Please call to inquire.

## Terms:

- 1) A 1% discount is given on merchandise if payment is made within 15 days from invoice date. This discount applies to the merchandise amount only (not the total amount) on the invoice (not a statement). The discount amount is shown in the lower left hand corner of the invoice. This discount does not apply to statement payments and does not apply to credit card orders.
- 2) Invoices not paid in full within 30 days from the statement date are subject to a finance charge of 1.5% per month (18% per year).

## Credit & Debit Card Orders:

Goodson accepts MasterCard, Visa, American Express and Discover Card. For your security, credit card numbers are NOT kept on file. Credit card orders do not qualify for the 1% quick-pay discount.



## Check Acceptance:

In the unlikely event that your check is returned for insufficient or held funds, we will debit your checking account electronically for the face amount of the check plus the service fee allowed by your state's law. This allows us to resolve the problem without turning you over to a collection agency and harming your credit rating. The transaction will appear on your bank statement and no one will have to contact you about payment.

## Returns:

You may return any item, except special orders, within 60 days. We will do our best to correct any problems or to send a replacement. If an item was damaged through mis-use or modification, Goodson will not accept it as a return. Credits will only be issued after it is determined that the part is resellable or it is deemed defective.

To return an item, please follow these easy steps:

1. Enclose a note explaining why you're returning the product. Be sure to include your name and account number (you'll find this on your invoice)
2. Ship the item freight prepaid within 60 days from invoice date to

**Goodson Tools & Supplies for Engine Builders**  
**ATTN: Returns**  
**156 Galewski Drive**  
**Winona, MN 55987**

For best results, please ship return merchandise by a trackable shipping method. Keep your receipt as it may be necessary to track the package if it is lost in transit. A 10% restocking fee applies on all returns unless the problem was the fault of Goodson. If so, the restocking fee is waived and shipping costs are reimbursed.

**ABRASIVES WARRANTY:** Abrasives have a shelf-life, therefore, all abrasives are warranted against manufacturing defects for 1 year from the date of original purchase.

## Privacy Policy:

All information that Goodson collects from its customers through purchases, credit applications or other transactions is kept private and is not disclosed to anyone except as permitted by law. Goodson will not sell or trade this information to anyone. Goodson will limit employee access to customers' private information to only those employees who need to know the information to provide products and services to you. Goodson maintains internal safeguards to protect our customer's non-public information. Please see our website [www.goodson.com/Privacy\\_policy/](http://www.goodson.com/Privacy_policy/) for details.

## International Sales:

All items shipped F.O.B. Winona, MN, USA. To find a distributor near you, visit [www.goodson.com](http://www.goodson.com).

Goodson currently has distributors in:

- Austria • Australia • Belgium
- Canada • Chile • Colombia
- Costa Rica
- Ecuador • El Salvador • Finland • France • Germany • Guatemala
- Honduras • Ireland • Italy • Mexico • Netherlands • New Zealand
- Norway • Poland • Puerto Rico • Spain • Suriname • Sweden
- Switzerland • Taiwan • Turkey • United Kingdom • Venezuela



## Resharpener & Resetting:

Goodson offers Resetter & Resharpener services for the following:

- Diamond Dressers • Brake Lathe Cutting Tips
- CBN & PCD Resurfacing Cutters
- Rotary Broach Tool Bits for Van Norman

Get more information and pricing by calling **1-800-533-8010**.

